

Continental 
The Future in Motion



Conveyor Belt

Installation, Maintenance
& Troubleshooting Guide

GOODYEAR
GOODYEARBELTING.COM

Call Toll Free: 1-866-711-4673
International: +1-727-342-5086

**We Ship
World Wide**

GOODYEAR
GOODYEARBELTING.COM

Call Toll Free: 1-866-711-4673
International: + 1-727-342-5086

**We Ship
World Wide**

Table of Contents

Installation

Storage	1
Handling	1
Installation	2
Stringing the Belt	5
Tensioning	5
Training the Belt	7
Factors Affecting the Training of a Belt	8
Sequence of Training Operations	13
Cleaning	15
Loading	17
Curved Chutes	20
Pulley Lagging	20
Types of Lagging	21
Transition Distances	23
Turnovers	24

Troubleshooting

Problems, Causes and Solutions	25
--------------------------------	----

Maintenance

Flexsteel® Belt Repairs	32
Ten Best Practices in Conveyor Belt Vulcanized Splicing	33

Shipping 39

Quick Check 40

Belt Roll Diameters 41

Terms and Conditions 43

Storage

The methods of storing and handling conveyor belting and the procedures for tensioning it before making the final splice are just as important as actually making the splice. Protect your conveyor belt investment with proper storage.

Belts should always be stored upright in the factory package until used in a cool, dry building and in an area free from sunlight. If possible, store the belt roll suspended on a tube, bar or support stand. Where suspension is not possible, the roll should be stored on a dry surface and rotated 90° every 6 months. Rotation should be performed in the same direction used to wind up the belt. Rotating in the opposite direction could cause the roll to loosen or telescope. It is particularly advisable to rotate a large roll of belting (over 25 tons) to prevent "flat spotting" (cold flow). This flow under pressure creates a thinner belt. Although this condition may correct itself after several months of operation, it is advisable to take steps for its prevention. If the belt is supplied on a steel reel, the belt would be considered as "suspended," and therefore not need rotation. Under no conditions should a roll of belt, especially raw edge or used, be laid flat on its side. Storing the belt flat on the ground, where moisture can penetrate exposed fabric, or storing the belt roll with weight on one edge may stretch the belt. This can cause belt camber or a bowing in the belt, resulting in serious belt mistracking.

During extended storage, the belt roll should be covered with a tarp or dark plastic. Exposure to sunlight, rain and ozone can have detrimental effects on the rubber covers. The cover should remain in place for the entire storage time.

It is important to make sure the belt is not exposed to extreme temperatures during storage. Ideal temperature for storing a belt is between 40°F (4°C) and 90°F (32°C). Temperatures outside of this range for an extended period of time can have detrimental effects on the rubber compounds.

As the length of time stored increases, and as the size of the roll of belting increases, so does the importance of the following correct storage procedures. Following these procedures will increase the life of the belt once it is installed on the system.

Even if the precautions outlined in this section are followed, it is still possible that the outside wrap of each roll may suffer excessive hardening or cracking during long-term storage. If this situation occurs, remove the outer turn of the roll to assure that optimum cover/carcass quality material is used for splicing.

Handling The Roll

Conveyor belting is customarily packaged in cylindrical reels, or rolls on a core with the carrying cover side facing out. If rolling is necessary, it should occur in a direction such that the end of the roll on the outside wrap travels in the direction from which it is wound up. Rolling in the opposite direction tends to loosen and telescope the belt.

Reels or rolls should never be dropped from a freight car, truck or other means of

conveyance, since their weight will break the packaging and may damage the belt. Reels or rolls should always be rolled or provision should be made for hoisting them. For hoisting, a square lifting bar of the correct size should be placed through the hole in the center of the core. A spreader bar should be utilized to prevent the chains or slings from damaging the edges of the conveyor belt. **Slings or chains of the correct size for the weight of the roll should be used (Fig. 1).**

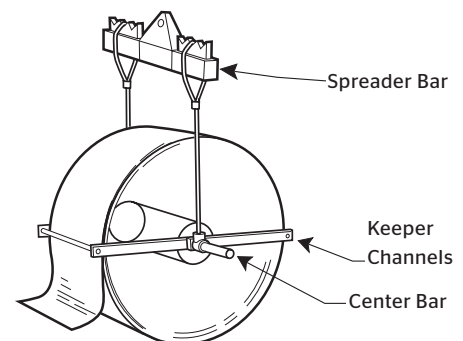

Fig. 1

Installation

The relative position of the top and bottom covers or surfaces of the belt should be considered when positioning the roll for threading. Once the roll of belting has been transported to the point of installation, it should be mounted on a suitable shaft for unrolling and threading onto the conveyor. Conveyor belting is normally rolled at the factory with the carrying side out. Consequently, in mounting the roll, the belt must lead off the top of the roll if it is being pulled onto the troughing or carrying idlers, but off the bottom of the roll if it is being pulled onto the return idlers. When pulling the belt onto the conveyor, the roll will turn opposite the direction indicated by the arrows on the crate. **Fig. 2 illustrates a suitable method of mounting, as well as leading off the top of the roll for pulling onto the troughing idlers.**

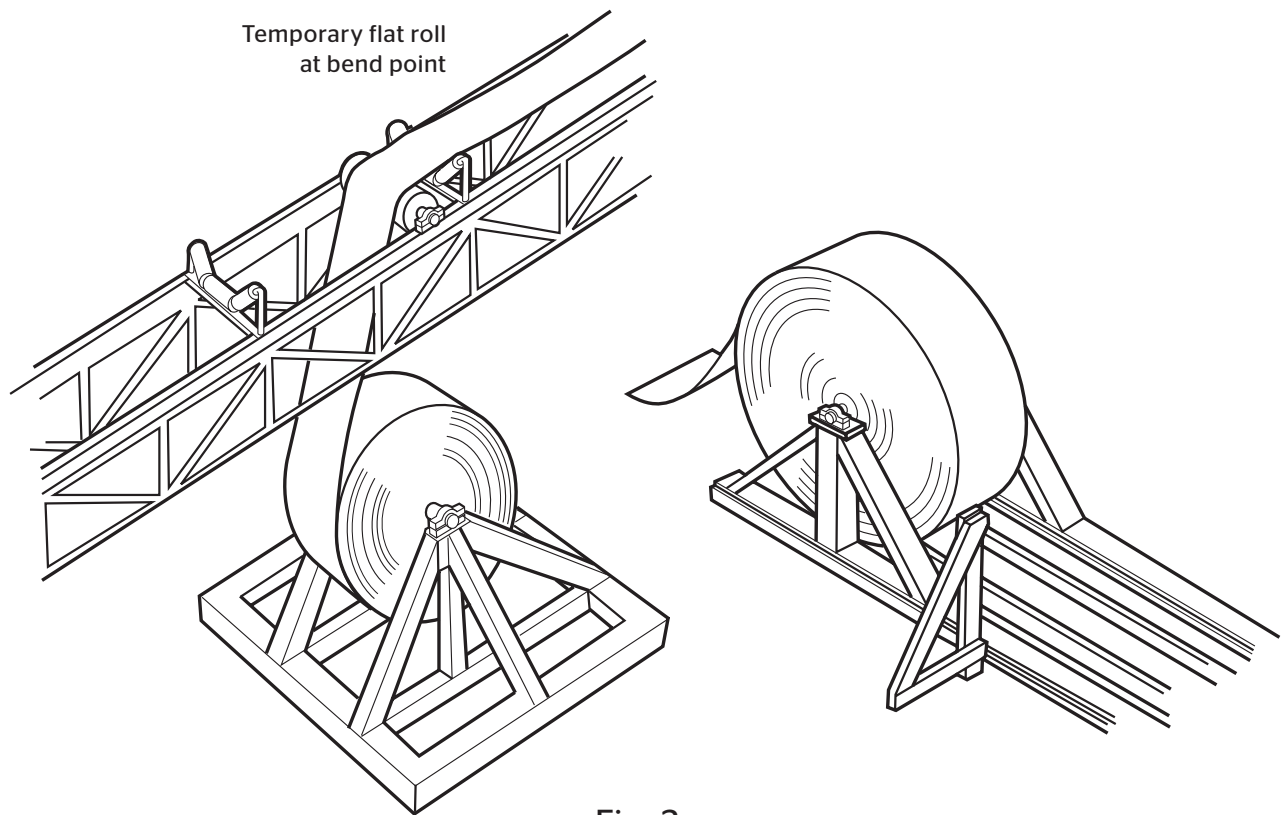

Fig. 2

Note: Temporary flat roll at bend point, as roll is pulled onto troughing idlers.

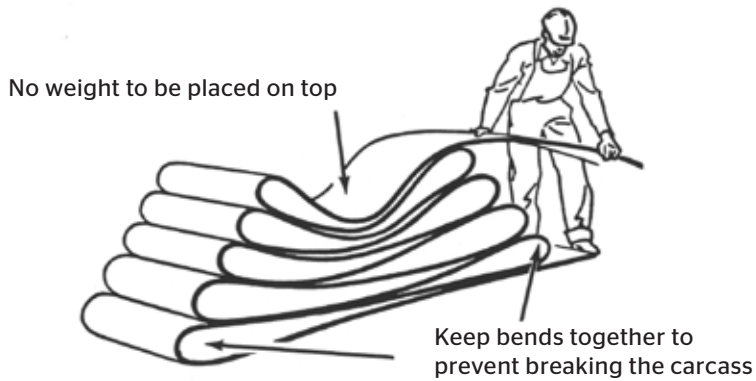

Fig. 3
Reefing the Belt

In some cases, such as in mines where headroom does not permit maneuvering a roll, the belt may have to be pulled off the roll and reefed (Fig. 3). Extreme care should be exercised to see that the loops have large bends to avoid kinking or placing undue strain on the belt, and no weight should ever be placed on the belt when it is in this position. Ideally, supports should be placed at each end where the bends occur.

A third method of handling the roll, where headroom for mounting on a horizontal shaft is lacking, is mounting on a turntable with a vertical spindle. The belt must make a 90-degree twist as it comes off the turntable. This method is sometimes used underground, with the turntable mounted on wheels or skids for transporting the roll of belt as it lies on its side, as well as for unrolling it at the final location.

If the belt is for replacement, the new roll can be set up as previously indicated. The old belt is clamped off and cut, and the new belt is spliced to the leading end of the old belt by using approximately one-half the usual number of plate-type fasteners. The trailing end of the old belt is hooked to a truck, tractor, mine locomotive or other means of providing

traction. The conveyor drive motor is used to pull on the new belt while the towing device drags the old belt away and at the same time provides sufficient slack side tension for the conveyor drive pulley. In all cases, care should be exercised to ensure the carrying side of the conveyor is placed upward if pulling onto the top run, or downward if pulling onto the return run.

For a new conveyor installation having little or no slope, a rope or cable should be attached to a clamp at the belt end. In clamping to the end of the belt for pulling it on the conveyor, it is not sufficient to cut a hole through the belt or ears into its corners for tying on a rope. A clamp should be made to distribute the pull applied to the end across its full width. Since the clamp must pass through

places of low clearance, it usually is made of two pieces of 1/4-inch to 1/2-inch plate approximately equal to the belt width and 4 inches long. One piece is placed against each surface of the belt at the end, and bolts are placed through both plates at about 6-inch intervals and 2 inches back from the belt end. The rope is then attached to this clamp with a shackle or by welding an eye to one of the plates. The belt roll has been handled as previously described. The rope or cable is then threaded over the conveyor and attached to a towing device to pull the belt onto the conveyor.

For installations with a relatively high degree of slope (12 degrees or more), the method of handling is slightly different. The roll of belt is set up as previously described. It is often found most convenient to place it at or near the head pulley, since this generally is the most accessible. Assuming the conveyor is sufficiently long to require more than one splice, the conveyor side and the return sides are threaded on separately. Care must be taken to see that conveyor side or heavier cover is up on the carrying side and down on the return run.

As the belt is fed on, the tension at the roll tends to build up due to the weight of the belt on the slope. For this reason, some method of braking is required. Customary practice is to use a belt clamp, mounted on the conveyor structure, through which the belt is threaded. Where the slope is very long, additional clamps should be spaced approximately 1000 feet apart. Where more than one clamp is used, workers are stationed at each clamp to loosen and tighten the clamps as the belt is fed onto the conveyor. Care must be exercised that the belt does not run away. As a roll runs out, another is spliced on and then fed onto the conveyor.

If the conveyor side and the return side have been fed on separately, the final splice is best made at the bottom of the slope where the ends of the belt meet, since a much lower splicing tension will serve at this point. Making the final splice at the top of the slope is entirely possible but requires proper splicing tension.

When pulling the belt onto the system, station personnel at key points along the conveyor to help avoid the belt from hanging up on the structure resulting in belt damage. Pull the belt ends until they overlap the required splicing length.

To prevent the belt roll from over-running at the let-off, a braking device is often needed (Fig. 4).

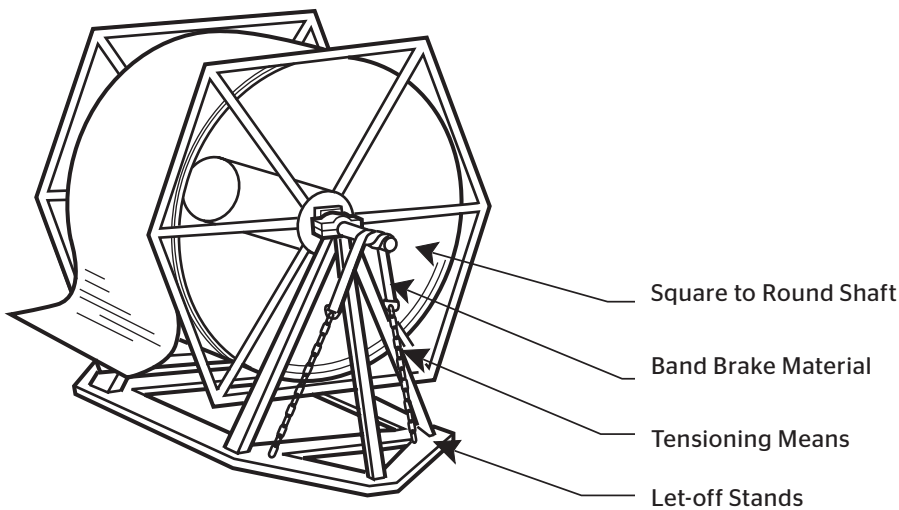

Fig. 4

Stringing The Belt

Textile Belts such as Pylon Plus®, Pylon®, Raider®, Pathfinder®, etc. that have been slit from a full-width slab at the factory should be spliced with the factory-cut edges on the same side of the conveyor (these edges are identified with white paint applied at the factory after slitting). The factory-edge side of slit belts will be identified by painting "Factory Edge" on that side and a solid white 3" strip will be painted across the full diameter of the same edge.

To minimize side travel on steel cord belt rolls, it is recommended that rolls be strung onto the conveyor in the exact sequence they were manufactured.

Tensioning

Once the belt has been pulled onto the conveyor system, it must be tensioned prior to splicing to facilitate correct positioning of the take-up and to eliminate sag. The tensioning operation takes place at the location where the last splice will be made. After final tensioning, clamps are placed on each end of the belt.

These are made of steel and have a clamping surface as indicated in Fig. 5.

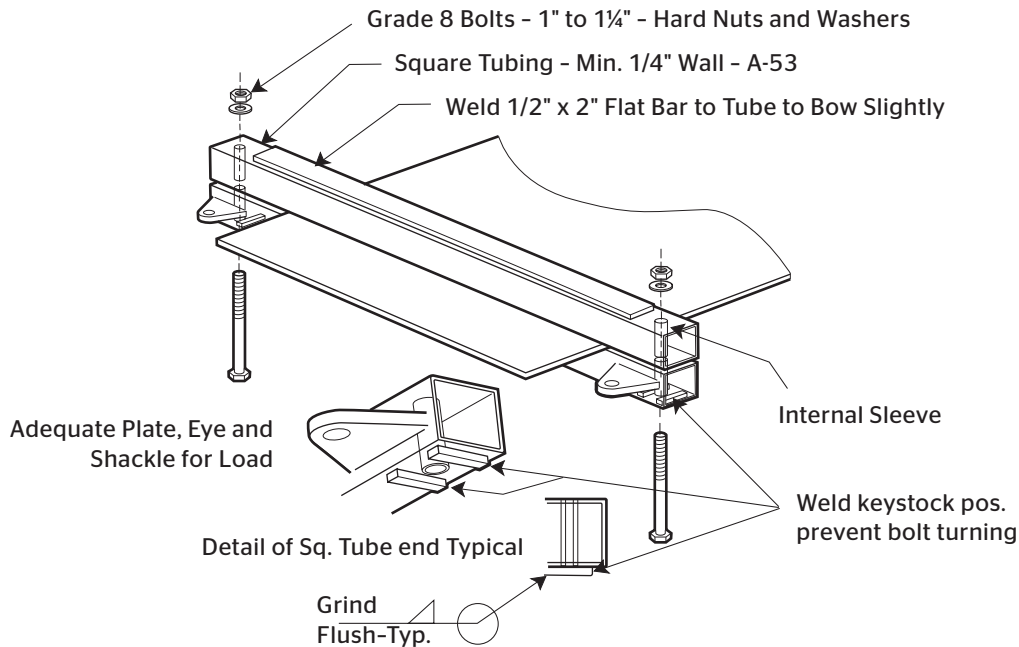

Fig. 5

Tension Clamp for Splicing

Tension is applied by means of a power device, which is used to pretension the belt before "clamping off."

When tension measuring load cells or scales are used, they are rigged to measure the pull on the take-up pulley. The belt is pulled until the load cells or scales register a tension equal to

or slightly greater than the recommended take-up force. Make allowance for an amount of belt necessary to correctly position the counterweight from this point.

Certain basic statements and recommendations can be made about tensioning for splicing:

- › Belts which are tensioned by pulling in only one direction require more splicing tension than those pulled in both directions.
- › Slope belts spliced at the top of the slope require more splicing tension than those spliced at the bottom.
- › Slope belts with an anti-rollback device that cannot be released must be tensioned by pulling only in the direction of belt travel.
- › Check the belt frequently during tensioning to ensure that the belt is free and not binding at any place.
- › During the final tensioning pull, be sure the ends of the belt are lined up properly.

Conveyor installations having limited take-up travel should be spliced to a tension based on the loaded running tension. This tension should be specified by our engineers and measured by suitable load cells or dynamometers. Where it is practical, fabric belts should be run for several weeks with mechanical fasteners before making the final vulcanized splice.

Obtaining the required tension depends heavily on the experience of the individual making the splice. It is possible for a gravity type take-up to severely damage the conveyor structure if it is positioned too close to the forward or

upward stop. Too much tension applied to a relatively short belt may thus have a harmful effect on the pulley shafts and bearings as well as the belt.

The belt may be tensioned with a suitable take-up device as follows:

When the counterweight is on: Tie the take-up off 6" to 8" (150mm to 200mm) above the desired running position (consideration may have to be made for excessive sag). Next, pull the belt until the take-up starts to lift and the tie-off ropes become slack. Make the final splice, allowing a minimum of belt slack.

When the counterweight is not on: Splicing without the counterweight installed is undesirable; however, the following procedure should be employed if necessary: Use suitable belt clamps to hold the take-up pulley 6" to 8" (150mm to 200mm) above the desired running position (consideration may have to be made for excessive sag). Pull the belt to its running tension, which can only be estimated in this situation. Judgment in estimating this tension will improve with the experience of the splicer.

Tables 1-1 and 1-2 show the recommended take-up travel and initial take-up position respectively.

Table 1-1 Recommended Minimum Take-Up Travel In Percent of Center Distance*

Type of take-up and carcass material [WARP]	Percent of rated tension		
	100%	75%	50% or less
Manual take-up**			
Nylon	4%	3%	2%
Polyester	2.5%	2%	1.5%
Aramid	2%	1.5%	1%
Fiberglass	1%	0.75%	0.5%
Automatic take-up**			
Nylon	3%	2.5%	1.5%
Polyester	1.7%	1.25%	0.75%
Aramid	1.5%	1%	0.75%
Fiberglass	0.5%	0.4%	0.25%
Steel	0.3%	1.23%	0.15%



Call Toll Free: 1-866-711-4673
International: +1-727-342-5086



Table 1-2 Recommended Initial Take-Up Position*

Carcass material [WARP]	Percent available for length increase	Percent available for length decrease
Steel	25%	75%
Nylon, Polyester, Aramid, Fiberglass	90%	10%

*Take-up conditions and travel amounts shown in Table 1-1.

Training the Belt

Training the belt is a process of adjusting idlers, pulleys, and loading conditions in a manner that will correct any tendency of the belt to run other than centrally. The following causes of common belt performance are considered axiomatic.

When all portions of a belt run off through a part of the conveyor length, the cause is probably in the alignment or leveling of the conveyor structures, idlers or pulleys in that region. If one or more portions of the belt run off at all points along the conveyor, the cause is more likely in the belt itself, in the joints of the belt, or in the loading of the belt. **When the belt is loaded off-center, the center**

of gravity of the load tends to find the center of the troughing idlers, thus leading the belt off on its lightly loaded edge (Fig. 6).

These basic rules can be used to diagnose belt running ills. Combinations of these rules sometimes produce cases that do not appear clear-cut as to cause, but if there are a sufficient number of

belt revolutions, the running pattern will become clear and the cause disclosed. The usual cases when a running pattern does not emerge are those of erratic running, which may be found with an unloaded belt that does not trough well, or a loaded belt that is not receiving its load uniformly centered.

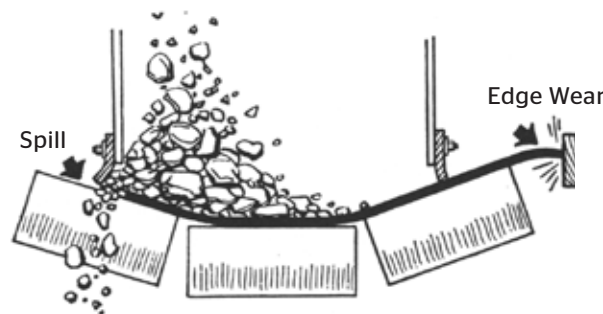

Fig. 6
Effects of Off-Center Loading

Factors Affecting the Training of a Belt

Pulleys and Snubs

Relatively little steering effect is obtained from the crown of conveyor pulleys. Crowning is most effective when there is a long unsupported span of belting (approximately four times belt width) approaching the pulley. Since this is not possible on the conveyor carrying side, head pulley crowning is relatively ineffective and is not worth the lateral mal-distribution of tension it produces in the belt.

Tail pulleys may have such an unsupported span of belt approaching them and may be crowned with benefit, except when they are at points of high belt tension. The greatest advantage is

that the crown, to some degree, assists in centering the belt as it passes beneath the loading point; this is necessary for good loading.

Take-up pulleys are sometimes crowned to take care of any slight misalignment that occurs in the take-up carriage as it shifts position. In general, crowned pulleys should be used sparingly, if at all, on fabric belts. With steel cord belts, all pulleys must be flat.

All pulleys should be level and should have their axis at 90 degrees to the intended path of the belt. They should be kept that way and not shifted as

a means of training, except that snub pulleys can have their axis shifted when other means of training have provided insufficient correction. Pulleys with their axis at other than 90 degrees to the belt path will lead the belt in the direction of the edge of the belt that first contacts the misaligned pulley. When pulleys are not level, the belt tends to run to the low side. This is contrary to the old rule-of-thumb statement that a belt runs to the high side of the pulley. When combinations of these two occur, the one having the stronger influence will become evident in the belt performance.

Carrying Idlers

The belt can be trained with the troughing idlers in two ways. Shifting the idler axis with respect to the path of the belt, commonly known as knocking idlers, is effective where the entire belt runs to one side along some portion of the conveyor. **The belt can be centered by knocking ahead (in the direction of belt travel) the end of the idler to which the belt runs (Fig. 7).** Shifting idlers in this way should be spread over some length of the conveyor preceding the region of the trouble. It will be

recognized that a belt might be made to run straight with half the idlers knocked one way and half the other, but this would be at the expense of increased rolling friction between belt and idlers. For this reason, all idlers initially should be squared with the path of the belt and only the minimum shifting of idlers used as a training means. If the belt is overcorrected by shifting idlers, it should be restored by moving back the same idlers, not by shifting additional idlers in the other direction.

Such idler shifting is effective for only one direction of belt travel. If the belt is reversed, a shifted idler, corrective in one direction, is misdirective in the other. Hence, reversing belts should have all idlers squared up and left that way. Any correction required can be provided with self-aligning idlers designed for reversing operation. Not all self-aligners are of this type, for some work in one direction only.

Tilting the troughing idler forward (not over two degrees) in the direction of belt travel produces a self-aligning effect. The idlers can be tilted in this manner by shimming the rear leg of the idler stand. Here again, this method is not satisfactory where belts may be reversing. **The tilted troughing idler is shown in Fig. 8.**

This method has an advantage over knocking idlers in that it will correct for movement of the belt to either side of the idler; hence, it is useful for training erratic belts. This method has

the disadvantage of encouraging accelerated pulley cover wear due to increased friction on the troughing rolls. It should, therefore, be used as sparingly as possible, especially on higher-angle idlers.

Special, self-aligning troughing idlers are available to assist in training the belt (Fig. 9). For a more complete discussion of these idlers, refer to the Continental ContiTech Handbook of Conveyor and Elevator Belting.

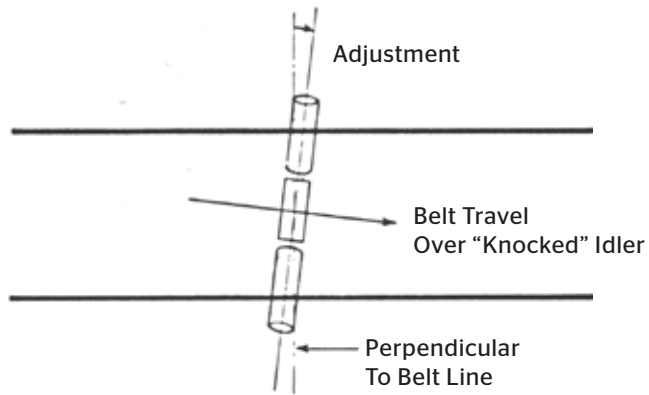

Fig. 7

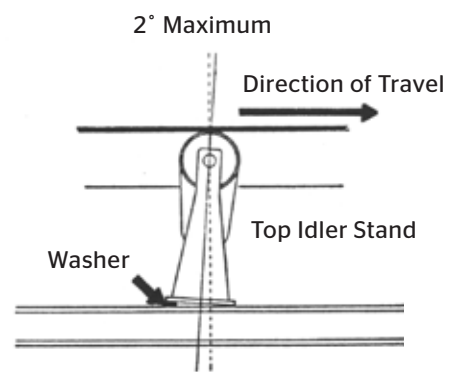
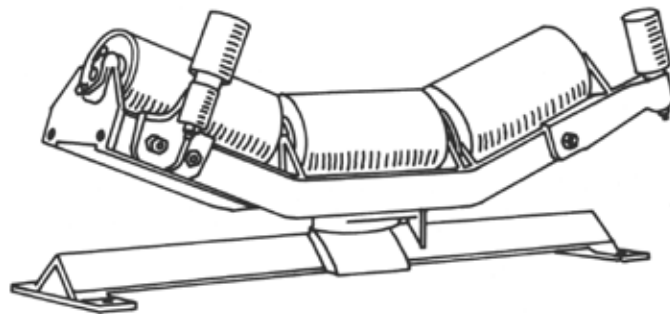

Fig. 8

Fig. 9
Typical Self-Aligning Troughing Idler



Return Idlers

Return idlers, being flat, provide no self-aligning influence as in the tilted troughing idlers. However, by shifting their axis with respect to the path of the belt, the return roll can be used to provide a constant corrective effect in one direction. As in the troughing rolls, the end of the roll toward which the belt is shifting should be moved longitudinally in the direction of return belt travel to provide correction.

Self-aligning return rolls also should be used. These rolls are pivoted about a central pin. **Pivoting of the roll about this pin results from an off-center belt and the idler roll axis thus becomes shifted, with respect to the path of the belt, in a corrective direction (Fig. 10).**

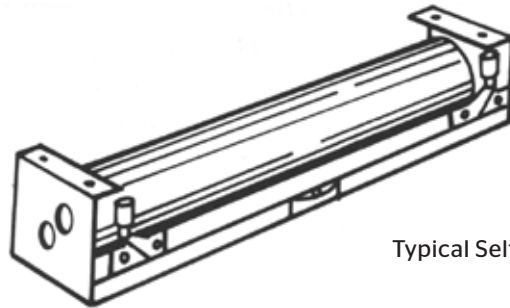

Fig. 10
Typical Self-Aligning Return Idler

Some return idlers are made with two rolls forming a 10-degree to 20-degree V-trough, which is effective in helping to train the return run. The V-return idlers are only recommended for fabric belts wider than 54". The most important criteria for belt training is idler contact in the center. If the belt has taken a set on the trough side and V-return idlers are

being used, the center of the belt is not able to make contact with the center of the V-return idlers. A hold-down roller on the return side will help in training the belt, as it forces the belt to lay flat on the following idlers.

Rubber-segmented disk return idlers (Fig. 11) are used for cleaning the belt

and help in belt training. When one of the discs on the edges falls off, the belt edges tend to get caught, forcing the belt to run one way and become a belt de-trainer. Minimum of 8" of belt contact is recommended for disc return idlers.



Fig. 11
Rubber Disk Return Idler

Automatic Aligning Devices

Self-aligning conveyor and return idlers have already been described. Center pivoted return idlers are sometimes connected in groups of two or three to operate together and are actuated by an external mechanism that takes its indication from the belt position. They have a very strong influence in centering the return belt as it approaches the tail pulley.

A snub pulley also can be arranged to provide the same strong self-aligning influence; however, in place of a center pivot (as in return rolls), it is usually pivoted at one end of its shaft. The other end is shifted by mechanical, electrical or hydraulic means as indication is received from the belt position.

Assuring Effectiveness of Training Rolls

Normally, extra pressure is desired on self-aligning idlers, and in some cases, on standard idlers where strong training influence is required. One way to achieve this is to raise such idlers above the line of adjacent idlers. Idlers or bend pulleys on convex curves along the return run have extra pressure due to a component of the belt tension, and are therefore effective training locations. However, carrying side self-aligners should never be located on a convex curve, since their elevated position can promote idler juncture failure.

Side Guide Rollers

Guides of this type are not recommended for use in making belts run straight. They can be used to assist in training the belt initially to prevent it from running off the pulleys and damaging itself against the structure of the conveyor system. They also can be used to afford the same sort of protection to the belt as an emergency measure, provided they do not touch the belt edge when it is running normally. If they bear on the belt continually, even though free to roll, they tend to wear off the belt edge and eventually cause ply separation along the edge. Side guide rollers should not be located so that they bear against the belt edge once the belt is actually on the pulley. **At this point, no edge pressure can move the belt laterally (Fig. 12).**

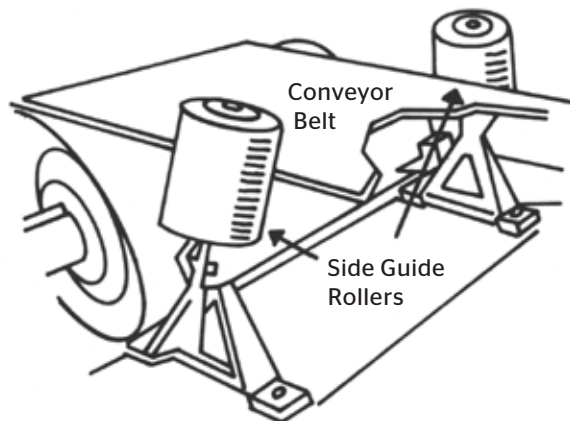

Fig. 12

The Belt Itself

A belt having extreme lateral stiffness, relative to its width, will be more difficult to train due to its lack of contact with the center roll of the carrying idler. Recognition of this fact enables the user to take extra precaution and, if necessary, load the belt during training to improve its steerability. **Observation of troughability design limitations will normally avoid this trouble (Fig. 13).**

Some new belts may tend to run off to one side, in a certain portion or portions of their length, because of temporary lateral mal-distributions of tension. Operation of the belt under tension corrects this condition in practically all cases. Use of self-aligning idlers will aid in making the correction.



Incorrect Troughing



Correct Troughing

Fig. 13

Sequence of Training Operations

Initial installation of conveyor equipment should ensure good alignment of all pulleys, troughing idlers and return idlers; that is, they should be placed at right angles to the direction of belt travel and should be leveled and centered on a straight line. First movement of the belt should be slow and intermittent so that any tendency of the belt to run off can be quickly observed and the belt stopped before damage occurs.

When the conveyor is a long center installation, men should be stationed at frequent intervals to observe the action of the belt. They should be provided with an effective method of communication so they can report their observations and if necessary, stop the belt.

Initial movement of the belt will indicate where corrections of the types described are required. The first corrections must be at points where the belt is in danger of being damaged. Once the belt is clear of all danger points, a sequence of training operations can be followed. Since the training will finally complete a circuit, just as the belt does, there is no point at which training can be started without the possibility of having to make subsequent corrections when returning to the starting point as the circuit is completed. The best procedure appears to be in starting with the return run and working toward the tail pulley. This ensures early centering of the belt on the tail pulley so that it can receive its load centrally, which is highly important.

If the belt is readily troughable so that its running tendencies are not erratic, the training can and should be completed on the empty belt. Should it tend toward stiffness and erratic running, getting some load onto the belt as soon as the return run has been straightened up and the belt is centered on the tail pulley will help hold the top run.

Normally, the belt can be trained properly onto the tail pulley by manipulation of return idlers and with the assistance of self-aligning return rolls. Seldom is any adjustment of snub or tail pulley necessary, but the snub can be used in supplementary training.

Training of the top run, with the belt empty, is usually no problem if the belt is readily troughable. In this case, self-aligners on top are not required, except as insurance in the region approaching the head pulley. There, two self-aligners placed approximately 40 and 80 feet preceding the pulley will help re-center

the belt if it is forced off due to some temporary disturbance.

It should not be necessary to use the head pulley for training purposes if it has been aligned properly. Likewise, the snub following the head pulley should not be required as a training means, since it is relatively ineffective in its position following the strong head pulley influence.

The take-up carriage has a strong influence on the running of the belt at that point, and due to its movement as belt length changes, is subject to misalignment. A vertical take-up carriage, hanging in a festoon of belt, must be guided in its travel so that the pulley shaft remains horizontal. The belt cannot be depended upon to center itself on the pulley. Once it becomes off-center, the pulley will tip out of horizontal if not guided closely on its posts.

A horizontal take-up carriage (Fig. 14) is subject to misalignment due to loose track gauge, fouled rails, or even jumping off the track. V-shaped rails will hold the gauge tight and, with the apex upward, are self-cleaning. Hold-down rails or hooks extending under the flange of the track structure will prevent jumping off the track.

With the empty belt trained satisfactorily, good operation with load is usually ensured. Disturbances that appear with load are usually due to off-center loading or to accumulation of material from the load on snub pulleys and return idlers.

When equipment is known to be properly aligned, training action should be taken slowly - that is, in small steps, because the belt requires some time to respond to corrective measures. It should begin at some point preceding the location where runoff occurs, and gradually proceed forward in the direction of belt travel, until the runoff condition has been corrected. Under some conditions of operation where the conveyor is not level, is extremely short or is too wide to be affected by permissible crowning, belts with a special guide strip have been used. This V-guide strip runs loosely in grooved pulley and idler rolls. Guide strips are not recommended nor are they necessary for the long conveyors normally encountered in industrial use.

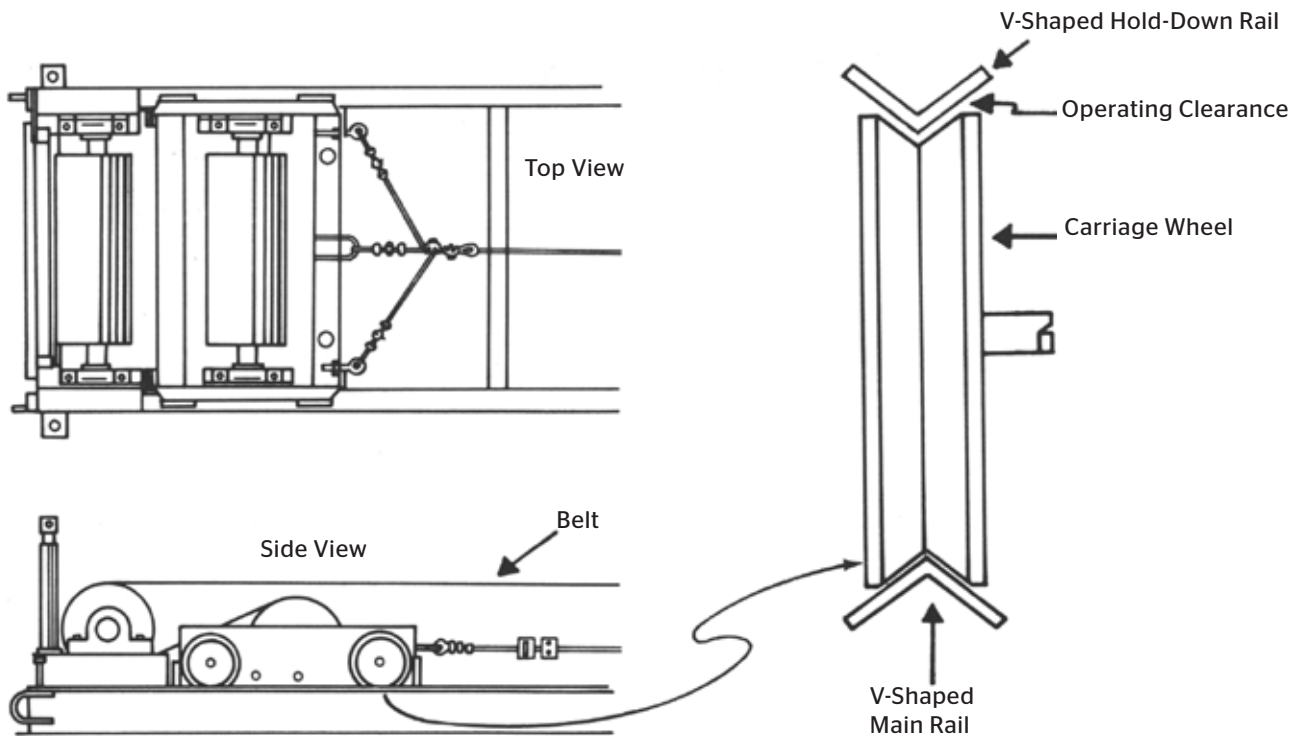

Fig. 14

Sample Horizontal Take-Up Carriage

Cleaning

Special care must be exercised to keep the return rolls and snub pulleys clean. Buildup of material on this equipment has a destructive effect upon training, with the result being that the belt may run against the structure and damage itself. It is advisable wherever possible that return idlers be suspended far enough below the structure so that any misalignment or dirty idlers can be easily seen. Keeping the return rolls and snubs clean requires that the belt be clean when it enters the return run. Scraping is the most common method of ensuring cleanliness.

Rubber scrapers can be made by clamping rubber slabs 1/2" to 1" thick (not old belting) between two metal or wooden bars. **Extend the rubber about twice its thickness beyond the bars and suspend the mechanism with a counter-weight to provide the pressure against the belt (Fig. 15).** Replace the rubber when it wears down near the bars. Two or three such scrapers can be used in succession. The most common steel scraper is a series of diagonally set blades mounted on the end of a leaf spring to maintain pressure against the belt. **These will scrape sticky materials that rubber scrapers may ride over (Fig. 16).**

Washing the belt with a water spray before wiping with a rubber scraper will do a good cleaning job on almost any material, including iron ores and mixed concrete.

Dry materials can be cleaned off the belt with rotating bristle or rubber vane brushes, driven at fairly high surface speed, usually three to five times the belt speed (Fig. 17). They wear rapidly, require considerable maintenance and are likely to fill up solid if used with wet and sticky materials. It is preferable to clean just after the head pulley and before the snub. An exception to this is that sticky material often requires scraping on the head pulley. This is because a large part of the fine material sticks to the belt and must be scraped into the chute.

In some cases, the best possible cleaning is insufficient and steps must be taken to compensate for the effect of a dirty belt. Snub pulleys can be kept from building up by using soft rubber lagging or by scraping directly against the pulley. Diagonal grooving will distort and discharge accumulations on these pulleys. **Rubber disc or spiral type return rolls prevent buildup on themselves and thus save a training problem (Figs. 18 & 19).**

The only cleaning required on the pulley side is removal of material, principally lumps, which may fall or bounce onto the return run and be carried between the belt and tail pulley if not removed (Fig. 22). Rubber-faced plows immediately in front of the tail pulley are used for this purpose (Figs. 20 & 21). They are usually held against the belt by gravity and set at an angle to the direction of belt travel.

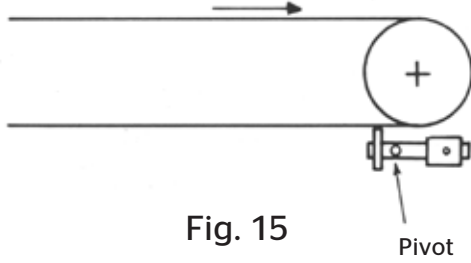

Fig. 15

Pivot

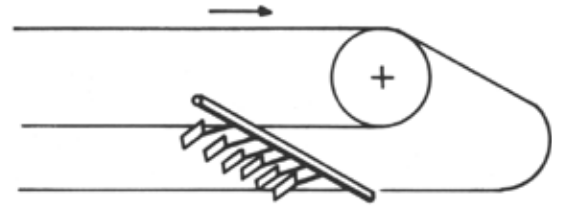

Fig. 16

Articulated Blade Scraper

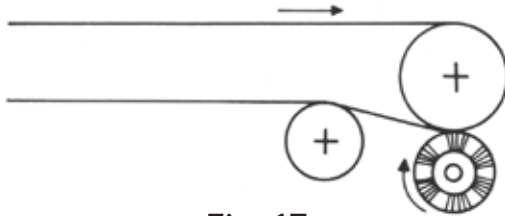

Fig. 17

Rotary Brush Scraper



Fig. 18

Spiral Return Idler



Fig. 19

Rubber Disk Return Idler

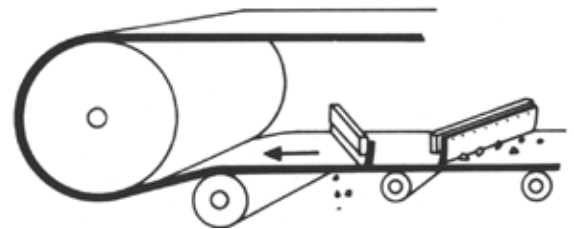

Fig. 20

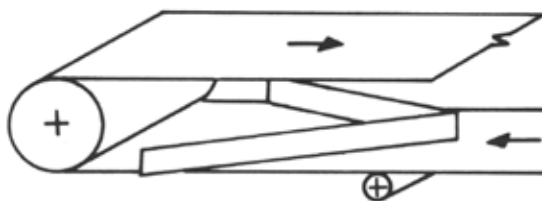

Fig. 21

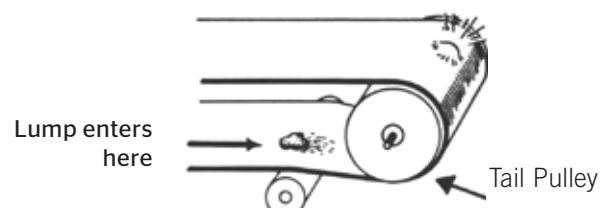

Fig. 22

Loading

Receiving material off center will cause the belt to move sideways after loading, as the center of the load seeks the lowest point in the troughing idlers. **This can be corrected by proper chute arrangement provided, of course, that the belt is centered as it enters the loading point (Fig. 23).**

The loading point of any conveyor is nearly always the critical point or the life-determining point of the belt. Here, the conveyor receives its major abrasion and practically all of its impact. The "ideal condition" is to have the material pass from chute to belt, at the same speed

and direction of travel as the belt and with a minimum amount of impact.

The subject of chute design and arrangement is too broad to be discussed in detail here. In lieu of such discussion, the following suggestions are offered:

The width of the receiving end of the loading chute should be great enough to accept material lying on the extreme edge of the preceding belt or feeder, and its position determined by the trajectory of the material coming into it. At no place should the chute be less than twice the

size of the largest lumps, if fines are present, and 3.5 times the size of lumps, if uniform. **The discharge width of the chute thus determined should not exceed about 2/3 of the receiving belts' width (Fig. 23).**

The slope of the chute is determined by the nature of the material, its entering velocity and length of the chute. This value varies with each particular installation, but about 35 degrees has been found satisfactory for most dry industrial materials such as coal and rock.

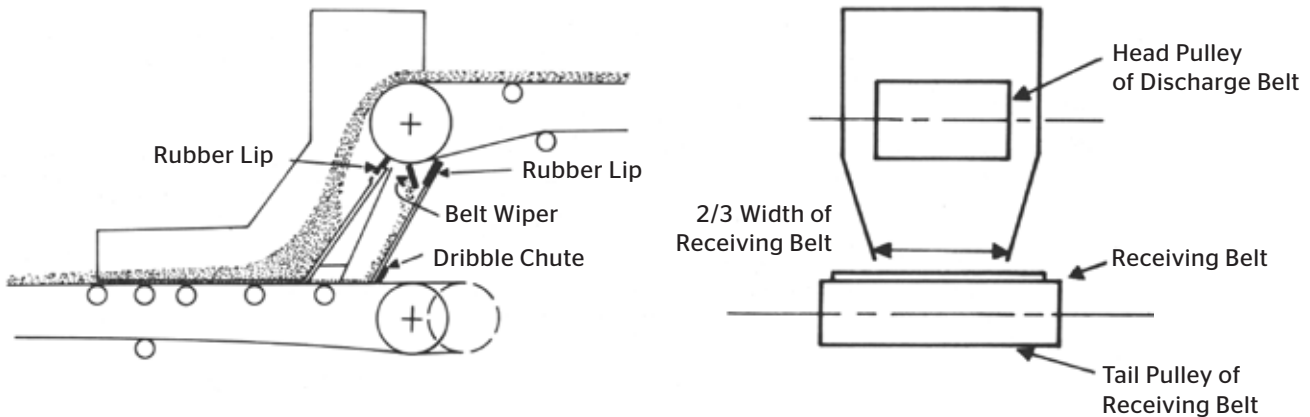

Fig. 23

Simple Conveyor Loading Point

An attempt to approach the above "ideal condition" should be made continually by adjusting the chute arrangement. Optimum loading and transferring through chutes still requires considerable experimental adjustment in the field.

Skirt boards should be used to further center and settle the load as it leaves the loading point. The steel structure of the

chute and skirts never should be placed closer to the surface of the belt than 1"; **this distance to be made increasing in the direction of belt travel to free any material trapped between the belt surface and the skirt (Fig. 24).** Skirt boards are usually 4 or 5 times the belt width in length, but may vary considerably due to belt speed, type of material and lump size. **Sample skirt board arrangements are shown in Fig. 25.**

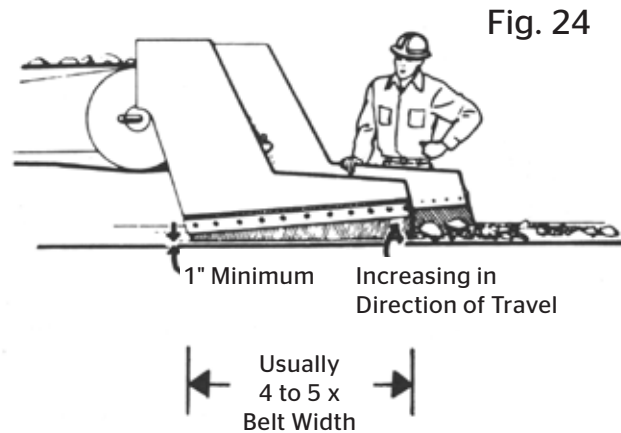

Fig. 24

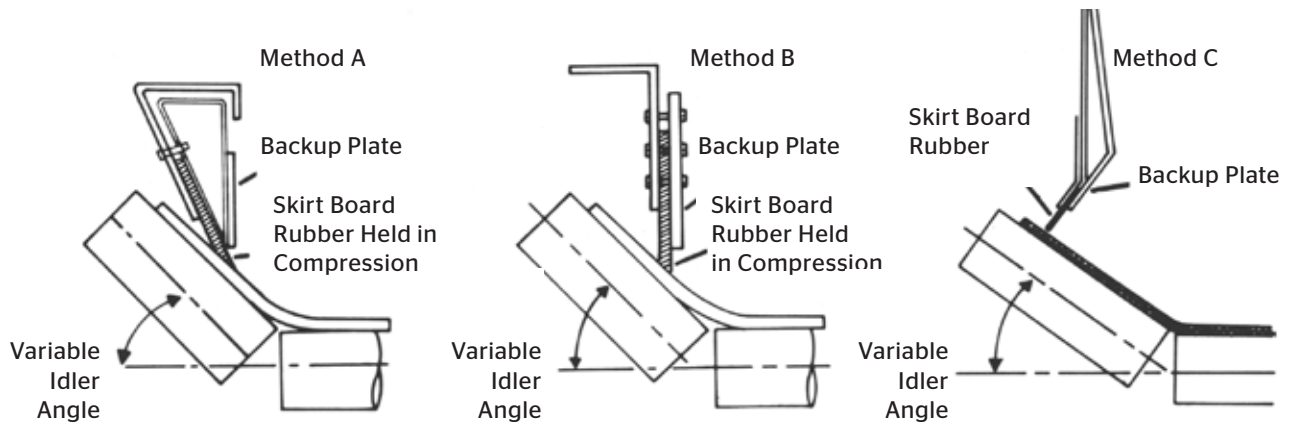

Fig. 25

Sample Skirt Board Arrangements

Impact of material being loaded on the belt is often the cause of severe cuts and gouges. **The degree of impact can be lessened to some extent by providing a cushion in the form of rubber covered disc type or semi-pneumatic idlers, which also tend to prevent material from crowding under the skirt boards at the instant of impact (Fig. 26).**

The use of a "Grizzly," a slightly fanned row of bars, at the bottom of the transfer chute reduces wear on the belt. It

distributes the impact of large lumps by allowing the fines to fall onto the belt first to act as a cushion. **The fan shape of the "Grizzly" in the direction of travel prevents jamming of the lumps (Fig. 27).**

A "V-slot" cut in the bottom of the chute is another very satisfactory method of allowing fines to fall on the belt before the lumps and thereby reducing belt wear at this point (Fig. 28).

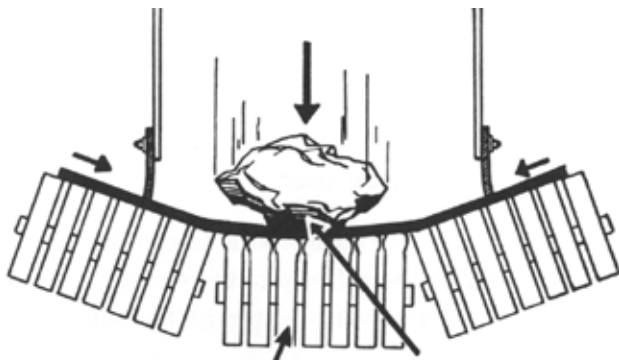

Belt cushioned by semi-pneumatic or rubber disc type idlers - preventing damage to belt
 Deflection instantaneous and localized

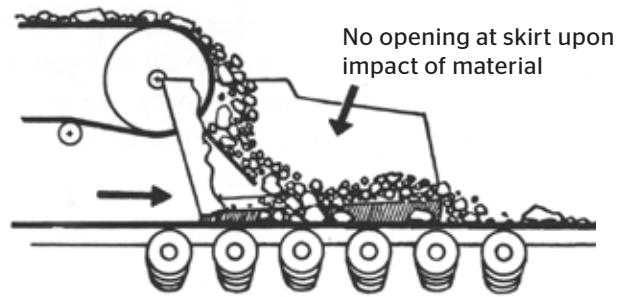

Semi-pneumatic or rubber disc type idler arrangement, placed as close together as possible

Fig. 26

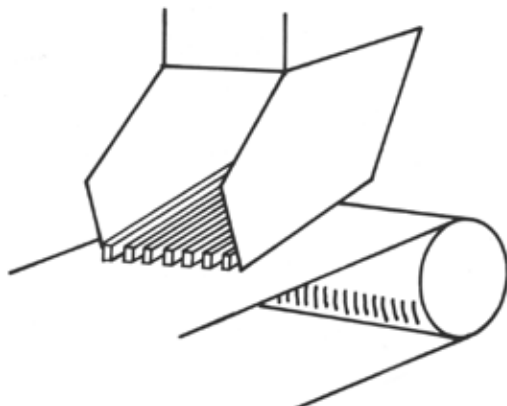

Fig. 27
 Grizzly Chute

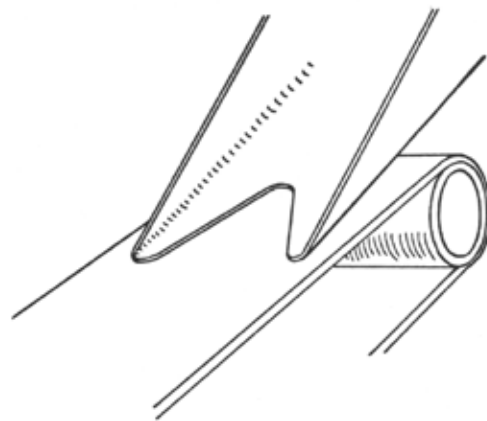

Fig. 28
 V-Slot Chute

Curved Chutes

Engineered loading chutes to reduce abrasion, cut/gouge and impact

Curved chutes are engineered chutes that allow the material to come in contact with the belt at a matching speed, with minimal drop height and with less turbulence. Curved chutes minimize abrasion, as well as cut/gouge and impact damage. Curved chutes may cost more than conventional

chutes, but help reduce wear and cut/gouge damage tremendously and will typically pay for themselves in a short time. Curved chutes are definitely recommended for new conveyors and for existing conveyors. **Special material flow modeling techniques are used to design curved chutes (Fig. 29).** Typically,

the chute is designed by consultant companies who have developed specialized software for studying the material flow inside the chute. With this software, they can easily compare the effectiveness of one chute design against another. The customer should go through the exercise of cost vs. return to see if a specialized curved chute design can be justified.

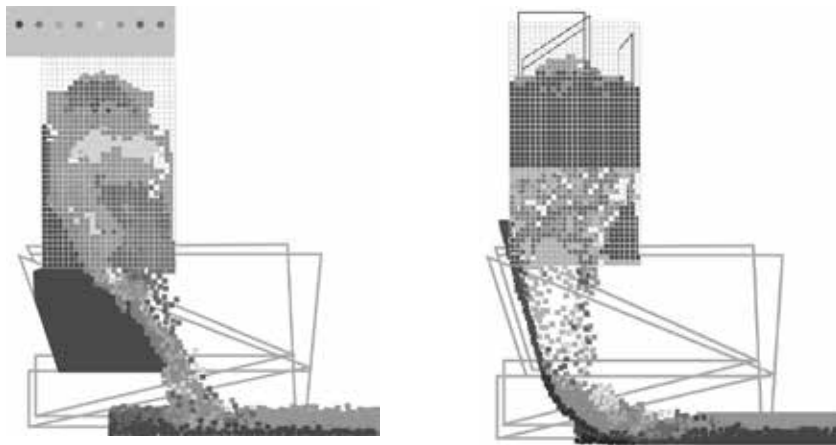

Fig. 29

Conventional vs Curved Chute

Pulley Lagging

Lagging is recommended for drive pulleys for the following reasons:

- › Improved co-efficient of friction. This permits a belt to be driven by lower slack side tension and sometimes results in lower total tension.
- › Reduction of slippage due to wet conditions, if grooved lagging is used.
- › Increased life for pulley and pulley cover of belt.

Other pulleys in the system, especially those contacting the carrying side of the belt, are often lagged to prevent buildup of material. Grooving improves cleaning action on the lagging and the belt.

Types of Lagging

1. Bolted lagging is usually fabric-reinforced, the fabric being necessary to give proper bolt-holding. This type has no inner or pulley cover; where no grooving is intended, 1/8" top cover is the proper minimum, but if the lagging is to be grooved, a minimum of 1/4" top cover must be used.

Bolted lagging is usually applied in two or more circumferential strips, applied under tension with the points in the different strips staggered around the pulley (On flat-faced pulleys, one strip the width of the pulley may be used).

For open-end pulleys 5/16" or 3/8" diameter flat head elevator bolts with nuts may be used. Alternate methods include slotted bolts with tapped holes or self-tapping screws for use in welded steel pulleys. It is necessary that the bolt heads be sunk below the level of the surrounding lagging to prevent damage to the belt as it passes over the pulley. This may be accomplished by counter-sinking the holes in the pulley or, where the lagging cover is greater than about 1/8", it is possible to sink the heads merely by tightening the bolts.

Ends of the strips should be bolted in a dovetail joint as shown in Fig. 30. In addition, bolts should be used in rows running across the face and around the circumference of the pulleys no further than 10" apart in either direction. Edges of all strips should be bolted down and it is recommended that all exposed fabric edges be cemented to keep out moisture.

2. Vulcanized lagging is a sheet of rubber, usually 1/2" thick and bonded directly to the metal. No fabric is used because no bolt-holding reinforcement is needed. It is much longer wearing, has better and more uniform adhesion to the pulley, and eliminates the hazard of serious belt damage due to a loose bolt.

This type of lagging can be applied in two different ways:

Spiral-wrap method - generally used for lower tension applications. **A 4" wide strip is recommended for ease of handling (Fig. 31).** The length of the strip may be calculated by the formula:

$$L = \frac{C \times W}{4} + C$$

In application by the sheet-wrap method, a beveled lateral splice is recommended (Fig. 32). The tie gum side should contact the beveled leading edge for maximum adhesion at the splice.

3. Grooved lagging should be used on drive pulleys if they are likely to be wet. The grooves break the film of moisture between the belt and lagging, thereby eliminating slippage. Either bolted or vulcanized lagging can be furnished with grooves. Either type can be grooved in the field with a tire-groover if there is sufficient rubber to prevent cutting into the fabric carcass or metal pulley. Herringbone grooving 3/16" deep and wide spaced 1" apart is recommended (Fig. 33).

4. A modified type of bolted pulley lagging is also available, featuring replaceable rubber pads that slip into metal guides bolted or welded to the pulley (Fig. 34).

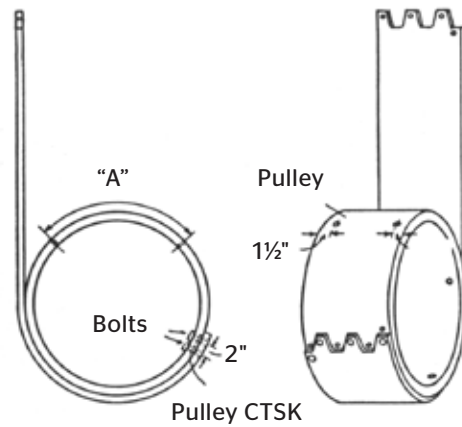
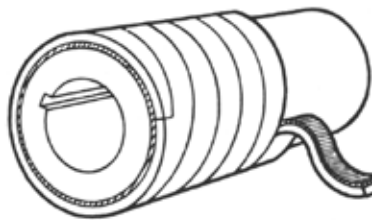
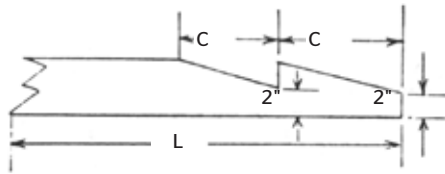

Fig. 30

Dovetailed Ends of Bolted Pulley Lagging



L = length of strip
C = pulley circumference
W = pulley width

$$L = \frac{CxW}{4} + C$$

Fig. 31

Spiral-Wrap Method of Applying Vulcanized Lagging

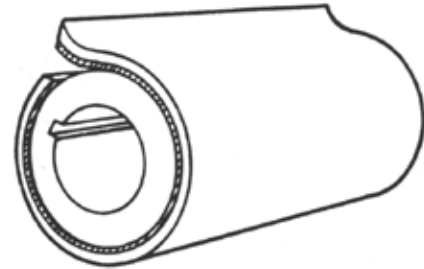

Fig. 32

Sheet-Wrap Method of Applying Vulcanized Lagging

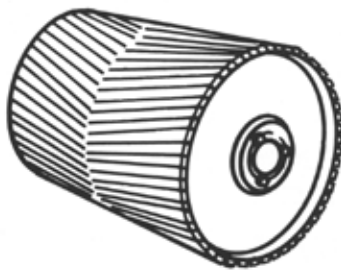

Fig. 33

Typical Herringbone Grooved Pulley Lagging

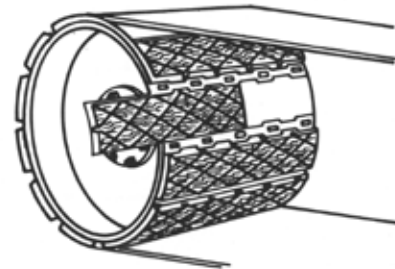
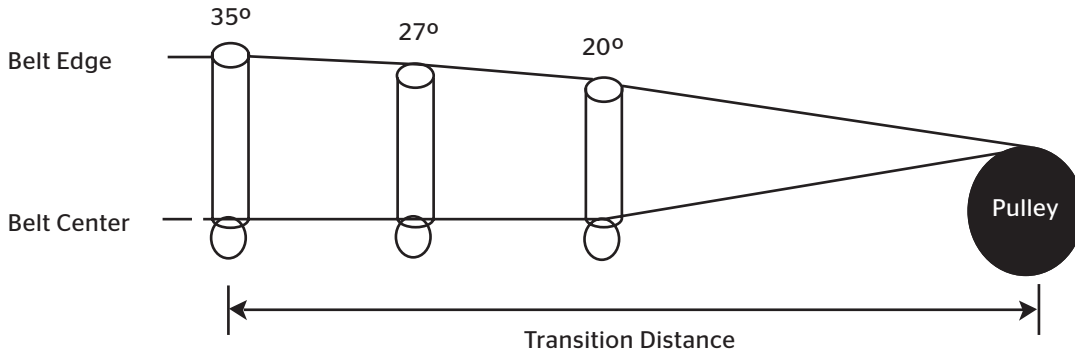

Fig. 34

Slide-Lag™ Replaceable Pad Pulley Lagging

Transition Distances

What is transition distance? Transition distance is the distance from the center of the head OR tail pulley to the first regular carry side idler.



Two common types of transition distances:

1. Full Trough

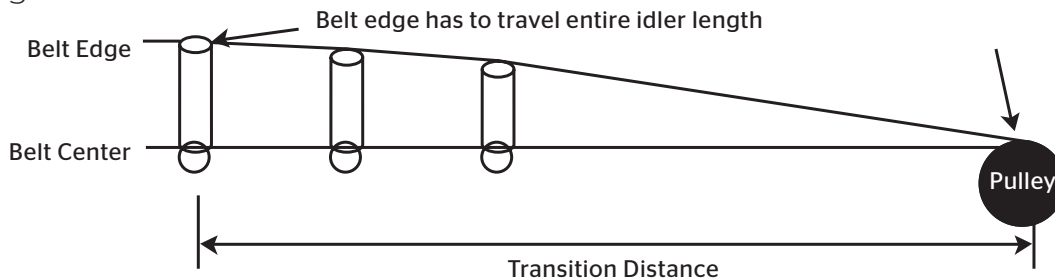

2. Half Trough

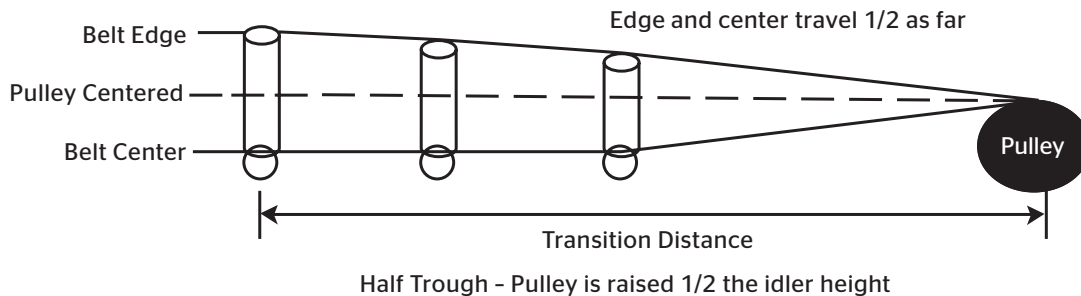

Why is transition distance so important? Short transitions create:

- › High Edge Tensions - Max = 115% of belt rated tension
- › Low Center Tension - Min = 0 piw (avoid compression)
- › Premature splice failure and idler junction failures

Confirm proper transition distance through Minuteman®



Call Toll Free: 1-866-711-4673
International: +1-727-342-5086



Turnovers

What is a belt turnover? A belt turnover is used for keeping the dirty side up on the return side for cleaning purposes.

Continental ContiTech belt turnover recommendation is as follows:

Vertical rolls should be located near the midpoint and 45-degree rolls located at quarter locations of turnover. The midpoint rolls should be on opposite sides of the belt and offset a few inches from each other so that a component of belt tension can provide pressure against each. They should be adjustable in all directions, as their ideal ultimate position rarely can be predetermined. These rolls aid in belt training, help minimize belt-

buckling tendencies and help stabilize a belt from excess flopping where winds are encountered.

The turnover must have two terminal pulleys (inbound and outbound), as shown in the picture below. This is to ensure that the belt is lying flat on the first bend pulley entering the transition and the last bend pulley leaving the transition.

Make sure the spacing between the vertical rolls is 2 ft (see picture). Each vertical roll also needs to be offset by 1" inward so that there is full belt contact on both rolls.

Each end pulley should have some adjustment in the plane of the approaching belt for training purposes.

The turnover length is determined by the belt width, type of construction and the belt tension at the turnover. Contact us for minimum turnover length after system analysis is performed.

Short transition distance can cause the belt to collapse in the turnover or cause excessive edge tension, which can in turn cause premature splice failure.

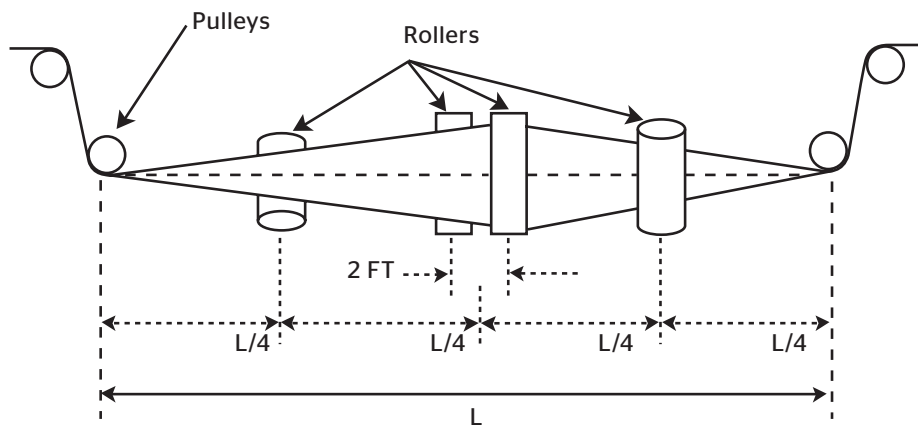

Troubleshooting

Problem: Conveyor runs to one side at given point on structure

Cause: Buildup of material on idlers
Solutions: Remove accumulation; improve maintenance; install scrapers or other cleaning devices

Cause: Sticking idlers
Solutions: Free idlers and improve maintenance and lubrication

Cause: Idlers or pulleys out-of-square with center line of belt
Solutions: Readjust idlers in affected area

Cause: Conveyor frame or structure crooked
Solutions: Straighten in affected area

Cause: Idler stands not centered on belt
Solutions: Readjust idlers in affected area

Cause: Structure not level
Solutions: Level structure in affected area

Problem: Particular section of belt runs to one side at all points on the conveyor.

Cause: Belt not spliced/joined squarely
Solutions: Remove affected splice and re-splice

Cause: Bowed belt
Solutions: For a new belt, this condition should disappear during break-in; in rare instances, belt must be straightened or replaced; check storage and handling of the belt rolls

Problem: Belt runs to one side for long distance or entire length of the conveyor

Cause: Belt running off-center around the tail pulley and through the loading area
Solutions: Install training idlers on the return side prior to the tail pulley

Cause: Off-center or poor loading
Solutions: Adjust chute to place load on center of belt; discharge material in direction of belt travel at or near belt speed

Cause: Buildup of material on idlers
Solutions: Remove accumulation; improve maintenance; install scrapers or other cleaning devices

Cause: Idlers or pulleys out-of-square with center line of the belt
Solutions: Readjust idlers in the affected area

Cause: Conveyor frame or structure crooked
Solutions: Straighten in affected area

Cause: Idler stands not centered on belt
 Solutions: Readjust idlers in affected area

Problem: Belt runs off at the tail pulley

Cause: Belt running off-center around the tail pulley and through the loading area
 Solutions: Install training idlers on the return side prior to the tail pulley

Cause: Material spillage and buildup
 Solutions: Improve loading and transfer conditions; install cleaning devices; improve maintenance

Cause: Idlers or pulleys out-of-square with center line of the belt
 Solutions: Readjust idlers in the affected area

Problem: Belt runs off at the head pulley

Cause: Pulley lagging worn
 Solutions: Replace the pulley lagging

Cause: Material spillage and buildup
 Solutions: Improve loading and transfer conditions; install cleaning devices; improve maintenance

Cause: Idlers or pulleys out-of-square with center line of the belt
 Solutions: Readjust idlers in the affected area

Cause: Idler stands not centered on the belt;
 Solutions: Readjust the idlers in the affected area

Problem: Belt slip

Cause: Insufficient traction between the belt and pulley:
 Solutions: Lag the drive pulley; increase the belt wrap; install belt-cleaning devices

Cause: Pulley lagging worn
 Solutions: Replace the pulley lagging

Cause: Counterweight too light
 Solutions: Add counterweight or increase the screw take-up tension to value determined from calculations

Cause: Material spillage and buildup
 Solutions: Improve loading and transfer conditions

Cause: Sticking idlers
 Solutions: Free idlers and improve maintenance and lubrication



Call Toll Free: 1-866-711-4673
International: + 1-727-342-5086



Problem: Belt slip on starting

Cause: Insufficient traction between the belt and pulley:
 Solutions: Lag the drive pulley; increase the belt wrap; install belt-cleaning devices

Cause: Counterweight too light
 Solutions: Add counterweight or increase the screw take-up tension to value determined from calculations

Cause: Pulley lagging worn
 Solutions: Replace the pulley lagging

Problem: Excessive belt stretch

Cause: Improper belt installation, causing excessive belt stretch
 Solutions: Pull belt through the counterweight with tension equal to at least the empty running tension; break belt in with mechanical fasteners

Cause: Improper initial positioning of the counterweight in its carriage, causing apparent excessive belt stretch
 Solutions: Check the Continental ContiTech Handbook of Belting for the recommended initial position

Cause: Insufficient counterweight travel
 Solutions: Consult Continental ContiTech Heavyweight Conveyor Belt Guide for recommended minimum distances; consult our Belt Engineers

Cause: Tension too high
 Solutions: Increase belt speed at same tonnage; reduce tonnage, maintain same belt speed; reduce friction with better maintenance and replacement of damaged idlers; decrease tension by increasing arc of contact or go to lagged pulley; reduce the counterweight to minimum amount

Cause: Counterweight too heavy
 Solutions: Lighten counterweight to the value required by calculations

Cause: System under belted
 Solutions: Recalculate belt tensions and select proper belt

Problem: Grooving, gouging or stripping of the top cover

Cause: Skirt boards improperly adjusted or wrong material
 Solutions: Adjust the skirt board supports to a minimum of 1" between metal and belt, with gap increasing in direction of belt travel; use skirt board rubber, not old belt

Cause: Belt spanking down under load impact
 Solutions: Install cushion idlers

Cause: Material hanging up in or under the chute
 Solutions: Improve loading to reduce spillage; install baffles; widen chute

Cause: Impact of material on the belt
 Solutions: Reduce impact by improving the chute design; install impact idlers

Problem: Excessive top cover wear, uniform around the belt

- Cause: Dirty, stuck or misaligned return rolls
Solutions: Remove accumulation; install cleaning devices; use self-cleaning return rolls; improve maintenance and lubrication
- Cause: Cover quality too low
Solutions: Replace with a belt of heavier-cover gauge or higher-quality rubber
- Cause: Material spillage or buildup
Solutions: Improve loading and transfer conditions; install cleaning devices; improve maintenance
- Cause: Off-center loading or poor loading
Solutions: Adjust the chute to place the load on the center of the belt; discharge material in the direction of belt travel at or near the belt speed
- Cause: Excessive sag between idlers causing the load to work and shuffle on the belt as it passes over idlers
Solutions: Increase tension if unnecessarily low; reduce idler spacing

Problem: Severe pulley cover wear

- Cause: Sticking idlers
Solutions: Free idlers; improve maintenance and lubrication
- Cause: Slippage on the drive pulley
Solutions: Increase tension through screw take-up or add counterweight; lag the drive pulley; increase arc of contact
- Cause: Material spillage and buildup
Solutions: Improve loading and transfer conditions; install cleaning devices; improve maintenance
- Cause: Material trapped between the belt and pulley
Solutions: Install plows or scraper on return run ahead of tail pulley
- Cause: Bolt heads protruding above lagging
Solutions: Tighten bolts; replace lagging; use vulcanized on lagging
- Cause: Excessive forward tilt of trough rolls
Solutions: Reduce forward tilt of idlers no more than 2 degrees from vertical

Problem: Longitudinal grooving or cracking of bottom cover

- Cause: Sticking idlers
Solutions: Free idlers and improve maintenance and lubrication
- Cause: Slippage on the drive pulley
Solutions: Increase tension through screw take-up or add counterweight; lag the drive pulley; increase arc of contact
- Cause: Material spillage and buildup
Solutions: Improve loading and transfer conditions; install cleaning devices; improve maintenance

Cause: Pulley lagging worn
 Solutions: Replace pulley lagging

Problem: Covers harden or crack

Cause: Heat or chemical damage
 Solutions: Use the belt designed for the specific condition

Cause: Improper storage or handling
 Solutions: Contact us for proper storage and handling instructions

Problem: Covers swell in spots or streaks

Cause: Spilled oil or grease; over-lubrication of idlers
 Solutions: Improve house keeping; reduce quantity of grease used; check grease seals

Problem: Belt breaks at or behind fasteners; fasteners pull out

Cause: Fastener plates too long for pulley size
 Solutions: Replace with smaller fasteners; increase pulley size

Cause: Wrong type of fastener; fasteners too tight or too loose
 Solutions: Use proper fasteners and splice technique; set up schedule for fastener inspection

Cause: Tension too high
 Solutions: Increase belt speed, same tonnage; reduce tonnage, maintain same belt speed; reduce friction with better maintenance and replacement of damaged idlers; decrease tension by increasing arc of contact or go to lagged pulley; reduce the counterweight to minimum amount

Cause: Heat or chemical damage
 Solutions: Use belt designed for specific conditions

Problem: Vulcanized splice separation

Cause: Belt improperly spliced
 Solutions: Re-splice using proper method as recommended by Continental ContiTech

Cause: Pulleys too small
 Solutions: Use larger-diameter pulleys

Cause: Tension too high
 Solutions: Increase belt speed, same tonnage; reduce tonnage, maintain same belt speed; reduce friction with better maintenance and replacement of damaged idlers; decrease tension by increasing arc of contact or go to lagged pulley; reduce the counterweight to minimum amount

Cause: Material trapped between belt and pulley
 Solutions: Install plows or scrapers on return run ahead of the tail pulley



Call Toll Free: 1-866-711-4673
International: + 1-727-342-5086



Cause: Improper transition between troughed belt and terminal pulleys
 Solutions: Adjust in accordance with our recommendations

Problem: Excessive edge wear, broken edges

Cause: Off-center loading or poor loading
 Solutions: Adjust chute to place the load on the center of the belt; discharge material in direction of belt travel at or near belt speed

Cause: Material spillage and buildup
 Solutions: Improve loading and transfer conditions; install cleaning devices; improve maintenance

Cause: Belt hitting structure
 Solutions: Install training idlers on carry and return run

Cause: Bowed belt
 Solutions: For a new belt, this condition should disappear during break-in; in rare instances, the belt must be straightened or replaced; check storage and handling of belt rolls

Problem: Transverse breaks at belt edge

Cause: Belt edges folding up on structure
 Solutions: Install limit switches; provide more clearance

Cause: Improper transition between troughed belt and terminal pulleys
 Solutions: Adjust transitions in accordance with Continental ContiTech Handbook of Conveyor and Elevator Belting

Cause: Severe convex (hump) vertical curve
 Solutions: Decrease idler spacing in vertical curve; increase curve radius; consult us for assistance

Problem: Short breaks in carcass parallel to belt edge, star breaks in carcass

Cause: Impact of material on the belt
 Solutions: Reduce impact by reducing the chute design; install impact idlers

Cause: Material trapped between belt and pulley
 Solutions: Install plows or scrapers on return run ahead of tail pulley

Problem: Ply separation

Cause: Insufficient transverse stiffness
 Solutions: Replace with the proper belt

Cause: Pulleys too small
 Solutions: Use larger-diameter pulleys

Cause: Heat or chemical damage
 Solutions: Use the belt designed for specific condition



Call Toll Free: 1-866-711-4673
International: + 1-727-342-5086



Problem: Carcass fatigue at idler junction

Cause: Improper transition between troughed belt and terminal pulleys
 Solutions: Adjust transition in accordance with Continental ContiTech Handbook of Conveyor and Elevator Belting

Cause: Severe convex (hump) vertical curve
 Solutions: Decrease idler spacing in curve; increase curve radius

Cause: Excessive forward tilt of troughed rolls
 Solutions: Reduce forward tilt of idlers to no more than 2 degrees from vertical

Cause: Excessive gap between idler rolls
 Solutions: Replace idlers; replace with heavier belt

Cause: Insufficient transverse stiffness
 Solutions: Replace with the proper belt

Cause: Excess gap between idlers, causing load to work and shuffle on the belt as it passes over idlers
 Solutions: Increase tension if unnecessarily low; reduce idler spacing

Problem: Cover blisters or sandblisters

Cause: Cover cuts or very small cover punctures allow fines to work under the cover and propagate between the cover and carcass
 Solutions: Make a vulcanized spot repair or a self-curing repair

Cause: Spilled oil or grease, over lubrication of idlers
 Solutions: Improve housekeeping; reduce quantity of grease used; check grease seals

Flexsteel® Belt Repairs

1. Repairs where there is no cable damage

- a. This type of damage may be repaired in a manner more or less normal with any belt in that the damaged area is thoroughly cleaned and dried, the damaged elements (cover, plies, insulation, gum, etc.) replaced and the new elements cured.
- b. If cable has been exposed it is important to use the proper cable cement and cable insulation gum at that point.

2. Repairs involving cable damage

- a. If cable damage involves less than 5% of the total cords in the belt at the edge or 10% of cords in the center of the belt, sections of new cable (or pieces cut from spare belt) should be worked in. This makes a more extensive repair as the new lengths of cable should extend 15" to 24" each side of the broken area. A large vulcanizer is usually required.
- b. If cable damage is greater than described in a., the belt should be respliced.

The covers are removed along with insulation gum from between cables. The new cable sections are simply placed between the old broken ones extending 15" to 24" each side of the break. Cable

cement, insulation gum and covers are applied and the repair is cured. The sketches below illustrate two methods used to step in lengths of new cable.

NOTE: When making cable repairs along belt edges, the tension must be removed from the belt. Even then the edge may be wavy because the new edge cables will not be carrying tension.

NOTE: • - Top Cover Cut
 •• - Pulley Cover Cut

Make approximately a 1" step between cover cuts around entire repair.

Existing Cables 
 New Cables 

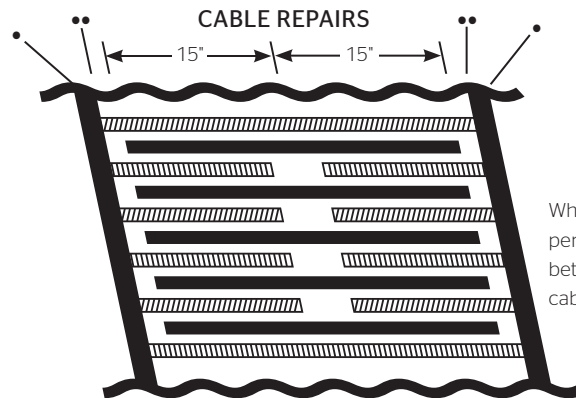

Where cable spacing is too close to permit new cable between two existing cables.

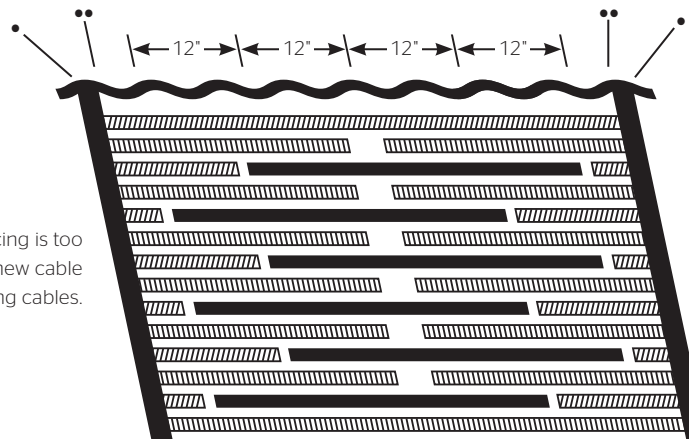

Ten Best Practices in Conveyor Belt Vulcanized Splicing

On a properly engineered, well-maintained conveyor system, a vulcanized splice done correctly will last for many years and in many cases will last the life of the belt.

Understanding and following the “**ten best practices in conveyor belt splicing**” is the best way to assure a vulcanized splice is done correctly.

Correctly performing each of the “**ten best practices in conveyor belt splicing**” when doing a fabric conveyor belt splice confirms the splicer is in **control of the process**.

Best Practice Number 1

Process control of the vulcanization curing temperature, curing time and curing pressure is vital.

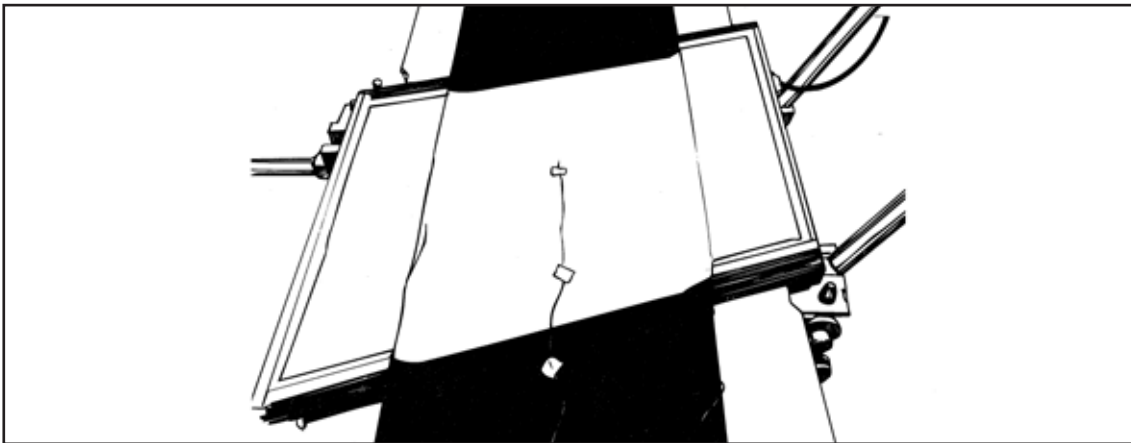

Thermocouples provide precise temperature monitoring at the platen-belt interface. A minimum of one thermocouple per platen is required. Thermostats on many vulcanizers do not indicate the actual temperature at the platen-belt interface. Without precise monitoring, the curing temperature can fluctuate drastically, resulting in a splice that is either over-cured or under-cured. Either condition will limit the life of the splice. Top

splicers such as those who are members of our Splice Network will always use thermocouples to monitor and gather cure temperature data. A record of this data can then be supplied to assure the curing process was done correctly. Top splicers will also assure that the vulcanizers' temperatures and pressure match those specified in our Splicing Manual of Continental ContiTech Custom Specifications.

Best Practice Number 2

Use the proper ply knives and techniques to avoid nicking the adjacent fabric plies while stripping down the belt.

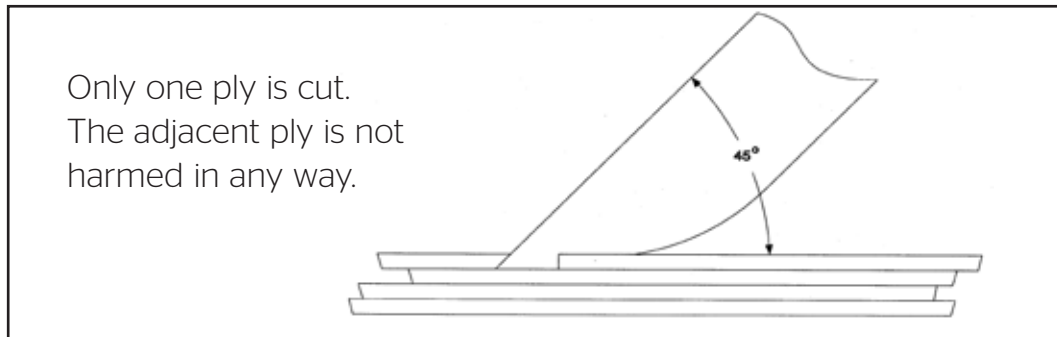

Nicking the adjacent fabric ply effectively reduces the tension rating of the belt, because the tension members (warp cords) are disabled if they are cut or nicked. Top splicers use top

quality tools such as the correct single-ply knives designed specifically for this operation. Utility knives are not acceptable and must not be used for this precise operation.

Best Practice Number 3

Buff the rubber surfaces only. Never directly buff the fabric.

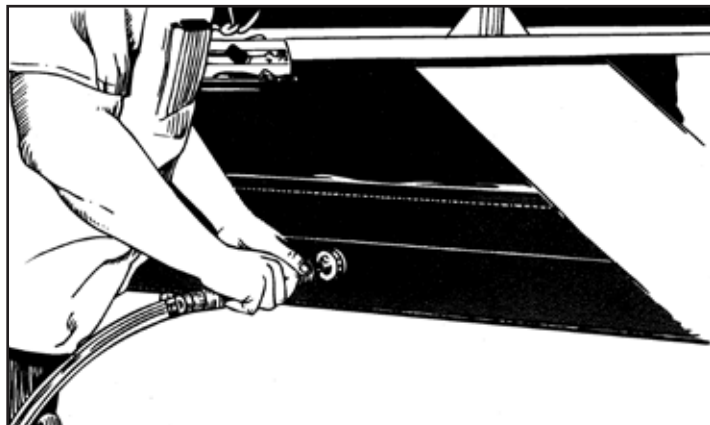

The fabric plies of all Continental ContiTech belts are coated with various "dip" coats that enhance the adhesion of the rubber to the fabric. These dip coats should not be buffed off when preparing the belt splice. Reduced ply and cover adhesion will result. If residual rubber must be buffed off after

the buffer wheel does not actually touch the fabric. Severe overbuffing will reduce belt strength and integrity by damaging both warp and fill cords. The buffer wheel should not exceed 2000 rpm. A fabric cement known as "kicker" should be used to replace the dip on exposed fabric.

Best Practice Number 4

Allow cements and solvent to dry completely before assembling the splice. When checking the cement for wetness/dryness, never use the palm of the hand or the palm side of the fingers. Oils may be transferred to the surface, which may reduce the adhesion value in this area. It is recommended to use the back side of the fingers.

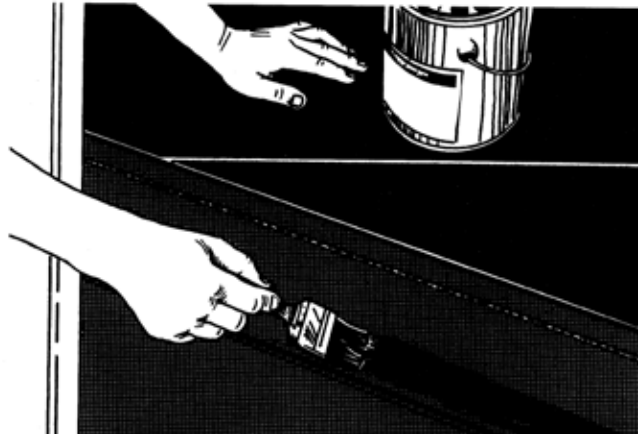

When a belt splice is assembled and cured before the cement has had sufficient time to dry, the heat from the vulcanizer will cause the solvents and carriers in the cement to vaporize and form bubbles / blisters. These bubbles / blisters are called "ply and/or cover blows." They will prevent adhesion between the plies and covers. If the surface area of the ply or cover blow is large enough and/or numerous, the strength of the splice is severely limited.

Ply and cover blows can also occur when cements and solvents are not allowed to reach room temperature after removal from cold storage because water condensation occurred on the cold surface.

Reliable splicers will allow sufficient time for cements to dry before assembly and for cold materials to warm up. Additionally, conscientious splicers will not try to accelerate the drying process

by using heat guns or hair dryers, since they can cause a skin to form on the surface of still-wet cements. Space heaters may be used to accelerate cement-drying time, as long as safety is not compromised in any way.

Best Practice Number 5

Avoid over-prodding the fabric when lifting the plies.

The right tools and methods will ensure that the fabric plies are not damaged when they are lifted. Prodding tools must have smooth, rounded corners. Prodding tools should be checked for possible burrs or nicks before each use.



Best Practice Number 6

Use the specified step, finger and bias lengths.

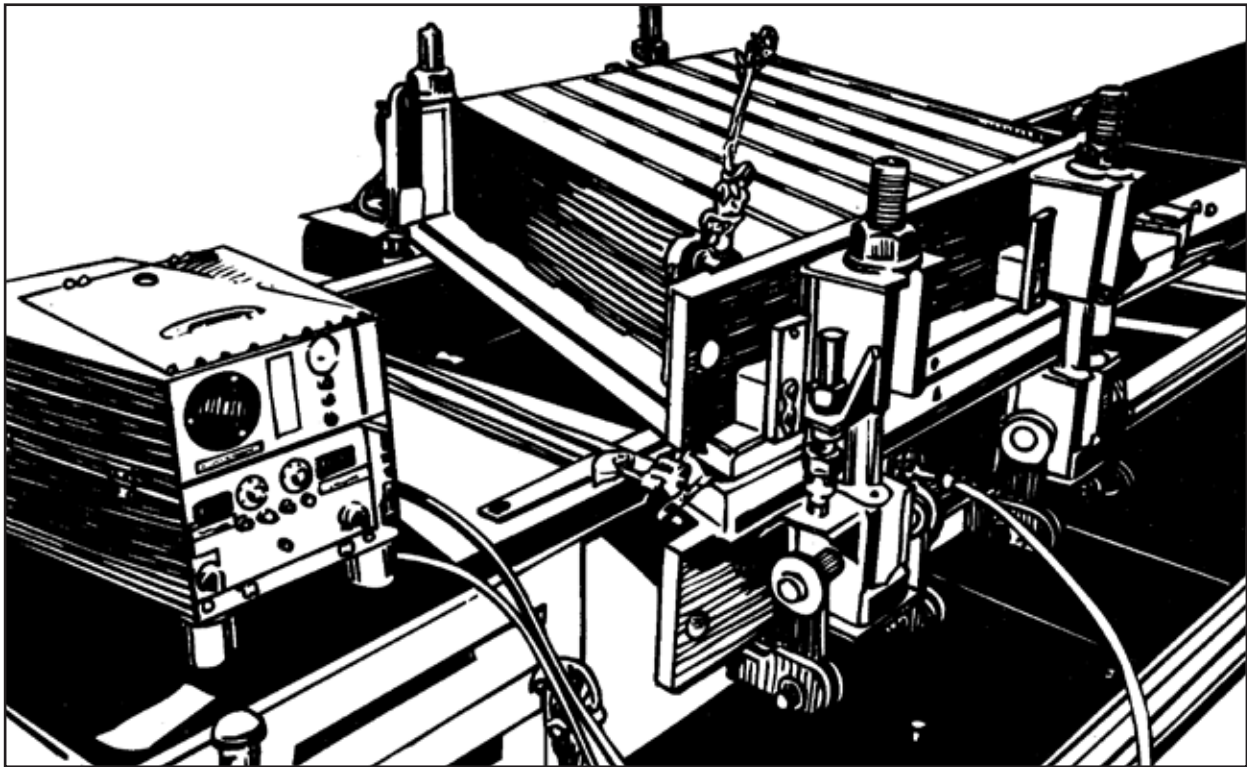

When step lengths are shortened to accommodate vulcanizers that are not large enough for the job, splice strength and integrity is severely reduced. Reputable splicers will always use the step lengths specified by the "Conveyor Belt Splicing Manual" or Continental ContiTech custom specifications. It is recommended to cure the entire belt splice in one heat;

multiple heats can be used as long as the cover fill-in strip area is completely cured in one heat. It is also recommended that pans are used at the top and bottom platens when multiple heats are needed. The pans and edge guides must cover the entire length of the platens and extend the length of the splice.

Best Practice Number 7

Have a clean work area to help ensure clean assembly of the splice.

Long experience has shown that almost anything can get inside a vulcanized splice. Our engineers and technicians have found tools, dust, trash, sand, insects, rocks and many other types of contamination inside of splices that have failed.

For these reasons, the splicing work area must be cleaned and protected. Tents, awnings, tarp, or temporary plywood walls and ceilings should be installed, depending on the particular circumstances in which the work must be done. These measures will help avoid contamination in the splice.

Best Practice Number 8

Never use cement or gums that are out of date.

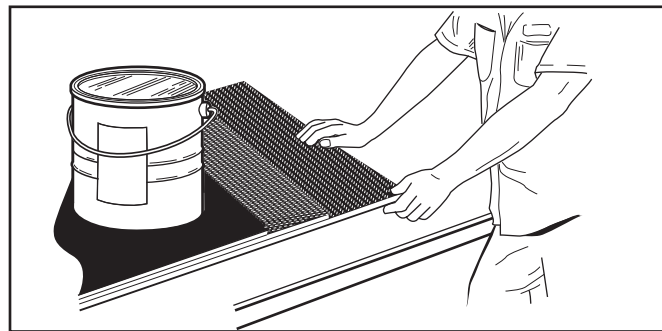

Continental ContiTech splice materials are manufactured to the highest standards. Part of this quality control includes recording on the labels the dates the materials were manufactured. Materials that are refrigerated will have

a longer shelf life than materials that are stored outside the refrigerated area. When unused materials reach the recommended storage-life limit, they should then be properly disposed of in complete accordance with federal, state

and local requirements. Splice materials should never be stored in sunlight or hot conditions. Never use overage splice materials. If in doubt - throw it out.

Best Practice Number 9

Use only the specified splice materials for the belt being spliced.

For best adhesion and splice life, Continental ContiTech conveyor belts should be spliced with Continental ContiTech splice materials. Only materials that have proven compatibility and supply the highest performance are supplied to our customers as splice materials.

Even with the use of Continental ContiTech splice materials, care must be used to ensure the correct gums and cements are used. Our Splice Coordinator can be consulted.

Best Practice Number 10

Align the space squarely and properly.

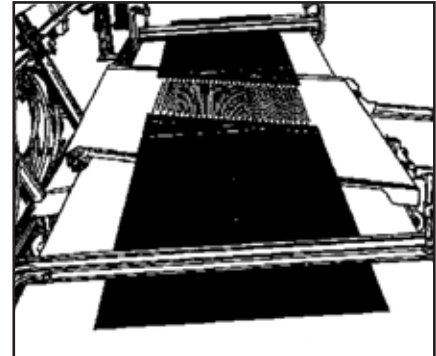
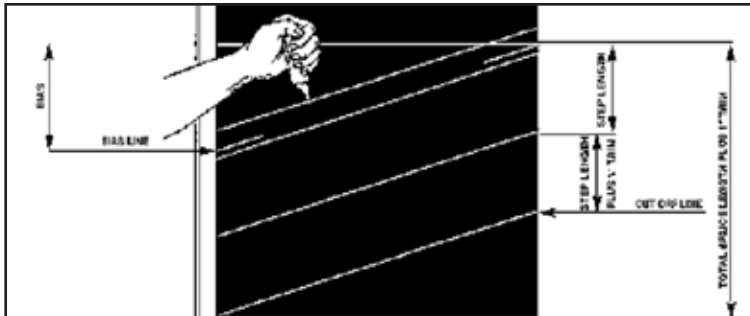

Splices that are not aligned cause many problems. Tracking and training problems can frequently be traced back to splices that are not square. Additionally, splices that are out-of-square do not distribute the tension load evenly across the splice, and

thus can cause premature splice failure. Reputable splicers go to great lengths to make certain that the belt is clamped securely and that all measurements, master lines and cuts are precise and accurate.

Conclusion

When the “**ten best practices in conveyor belt splicing**” discussed above are incorporated into your standard operating procedures and specifications, and the conveyor system is properly engineered and well-maintained in the first place, a dependable, long splice life can be obtained.

Please consult your local Sales Representative for further information regarding:

- › Continental ContiTech Total Belt Service™ splice materials
- › Conveyor Belt Splicing Manual
- › Splice Network Members
- › Any other technical or product question

Maximum Roll Diameters for Various Shipping Methods

Van:

84" (2.1m) Max.
Roll Diameter

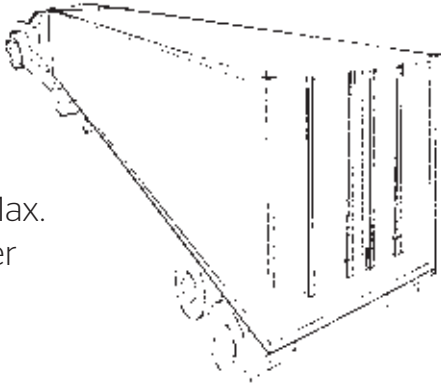

Rag Top or Open Top:

101" (2.5m) Max. Roll Diameter

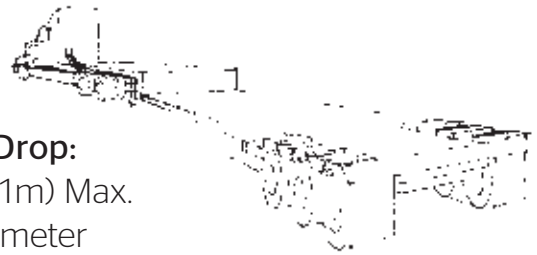

Single Drop:

122" (3.1m) Max.
Roll Diameter

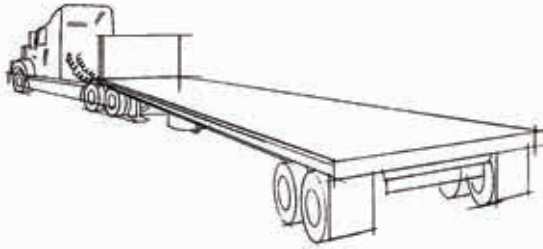

Flat Bed:

103" (2.6m) Max.
Roll Diameter

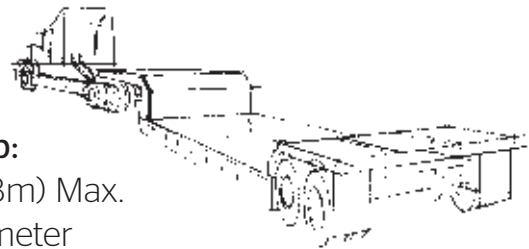

Bath Tub:

152" (3.8m) Max.
Roll Diameter

Low Boy:

144" (3.6m) Max.
Roll Diameter

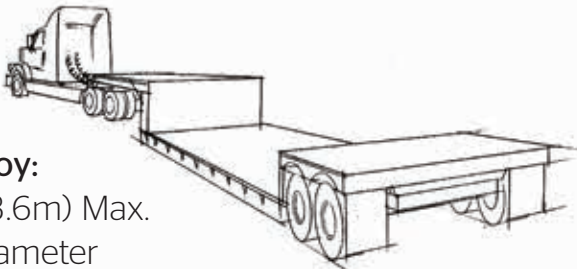

If shipment on flat bed or single drop exceeds 40,000 lbs., shipment on low boy or bath tub exceeds 36,000 lbs. or shipment exceeds listed maximum roll diameters, please contact Customer Service - 1-800-BELT-USA, or our Bowmanville, Ontario, Canada facility at 1-800-262-7799 for additional charges.

Quick-Check method for approximate maximum tension (Tm) used only on existing conveyors which require power when loaded.

NOTE: Do not use for decline belts.

Many small conveyors require more carcass for load support and impact than is required for maximum tension. For that reason, the belt selection is based primarily on load support, pulley diameter, impact and cost. However, during the investigation of such belts, it is advisable to check the possibility that maximum tension may be a factor.

In such cases, QUICK-CHECK offers a quick, simple method of **approximating** the maximum tension. If the result is low enough to show that tension is not a factor, then no further calculations are required. However, if the result indicates tension may be a factor, then more data should be gathered and maximum tension calculated using the appropriate formulas.

The appropriate maximum tension will normally be higher than that obtained through the regular formulas. To determine the approximate maximum tension using QUICK-CHECK:

IMPERIAL

1. Find the proper belt speed, type of take-up, and type of pulley; the corresponding number is the approximate maximum tension per motor horsepower.
2. Multiply this number (Tm, approximate maximum tension per motor horsepower) by motor horsepower to obtain approximate maximum tension in pounds.
3. Divide the approximate maximum tension in pounds by the belt width to obtain the approximate required piw.
4. If the approximate piw is equal to or greater than the tension rating of the load support belt, then a more accurate maximum tension should be calculated. Contact your local Continental ContiTech distributor.

METRIC

1. Find the proper belt speed, type of take-up, and type of pulley; the corresponding number is the approximate maximum tension per motor kilowatt.
2. Multiply this number (Tm, approximate maximum tension per motor kilowatt) by motor kilowatts to obtain approximate maximum tension in newtons.
3. Divide the approximate maximum tension in newtons by the belt width to obtain the approximate required N/mm or kN/m.
4. If the approximate Tm is equal to or greater than the tension rating of the load support belt, then a more accurate maximum tension should be calculated. Contact your local Continental ContiTech distributor.

Imperial Values

Quick-Check method for maximum tension – single pulley drives

Belt speed "S" (ft./min.)	Approx. "Tm"—lbs. per Motor HP (Power Requiring Conveyors only) (10% Drive Losses)			
	Counterweight take-up		Screw take-up	
	Lagged pulley	Bare pulley	Lagged pulley	Bare pulley
50	820	892	986	1070
100	410	446	493	535
150	273	297	329	356
200	206	224	248	268
250	164	179	198	224
300	136	148	164	178
350	117	127	141	153
400	102	111	123	133
450	91	99	110	119
500	83	90	100	108
550	75	81	90	97
600	69	75	83	90
650	64	69	77	83

Metric Values

Quick-Check method for maximum tension – single pulley drives

Belt speed "S" (ft./min.)	Approx. "Tm"—lbs. per Motor HP (Power Requiring Conveyors only) (10% Drive Losses)			
	Counterweight take-up		Screw take-up	
	Lagged pulley	Bare pulley	Lagged pulley	Bare pulley
0.25	4968	5400	5976	6480
0.50	2484	2700	2988	3240
0.75	1656	1800	1992	2160
1.00	1242	1350	1494	1620
1.25	994	1080	1195	1296
1.50	828	900	996	1080
1.75	710	771	854	926
2.00	641	675	747	810
2.25	552	600	664	720
2.50	497	540	598	648
2.75	452	491	543	589
3.00	414	450	498	540
3.25	382	415	460	498
3.50	355	386	427	463
3.75	331	360	398	432
4.00	310	337	374	405



**Call Toll Free: 1-866-711-4673
International: +1-727-342-5086**



IMPERIAL BELT ROLL DIAMETERS

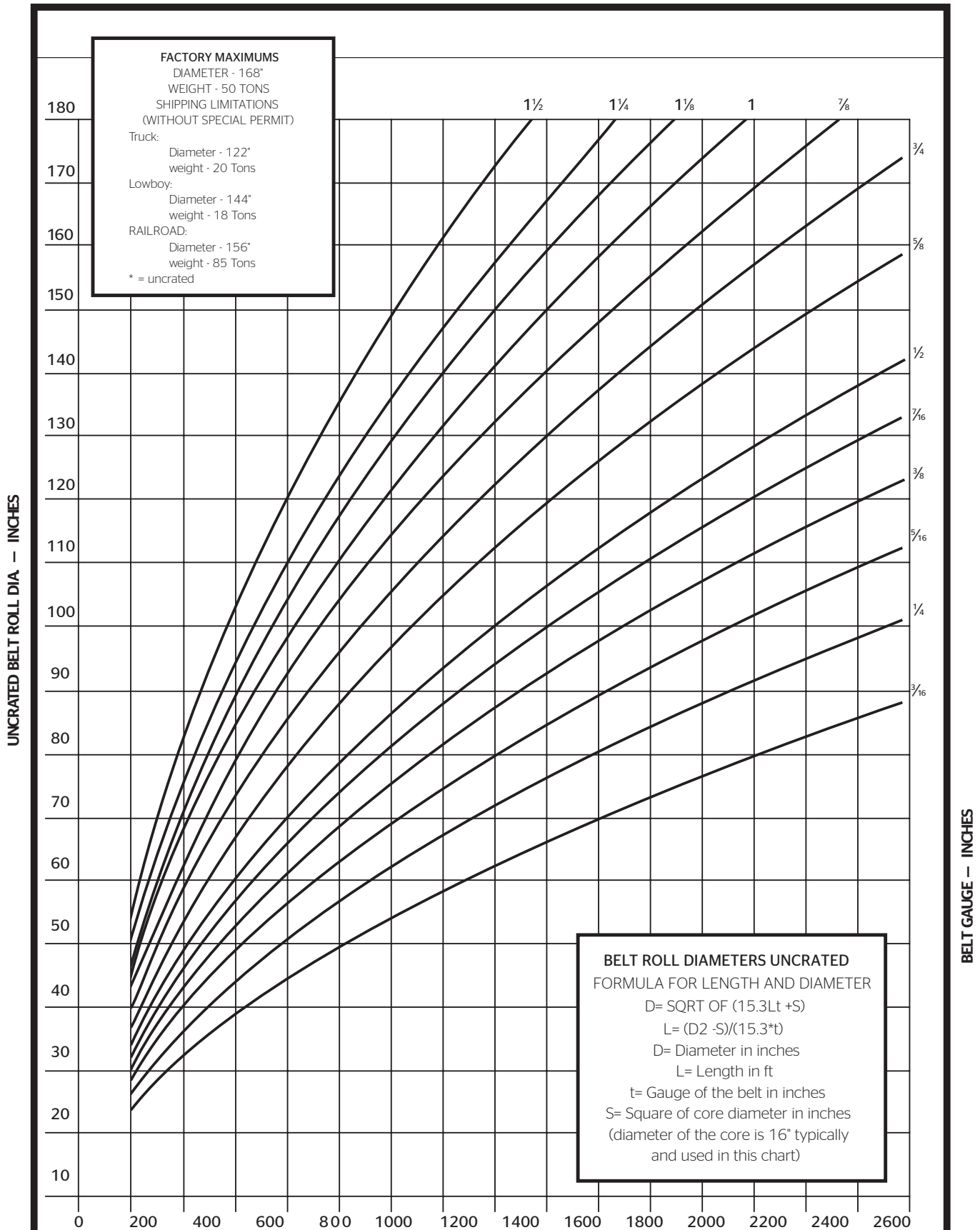

Call Toll Free: 1-866-711-4673
International: +1-727-342-5086



METRIC BELT ROLL DIAMETERS

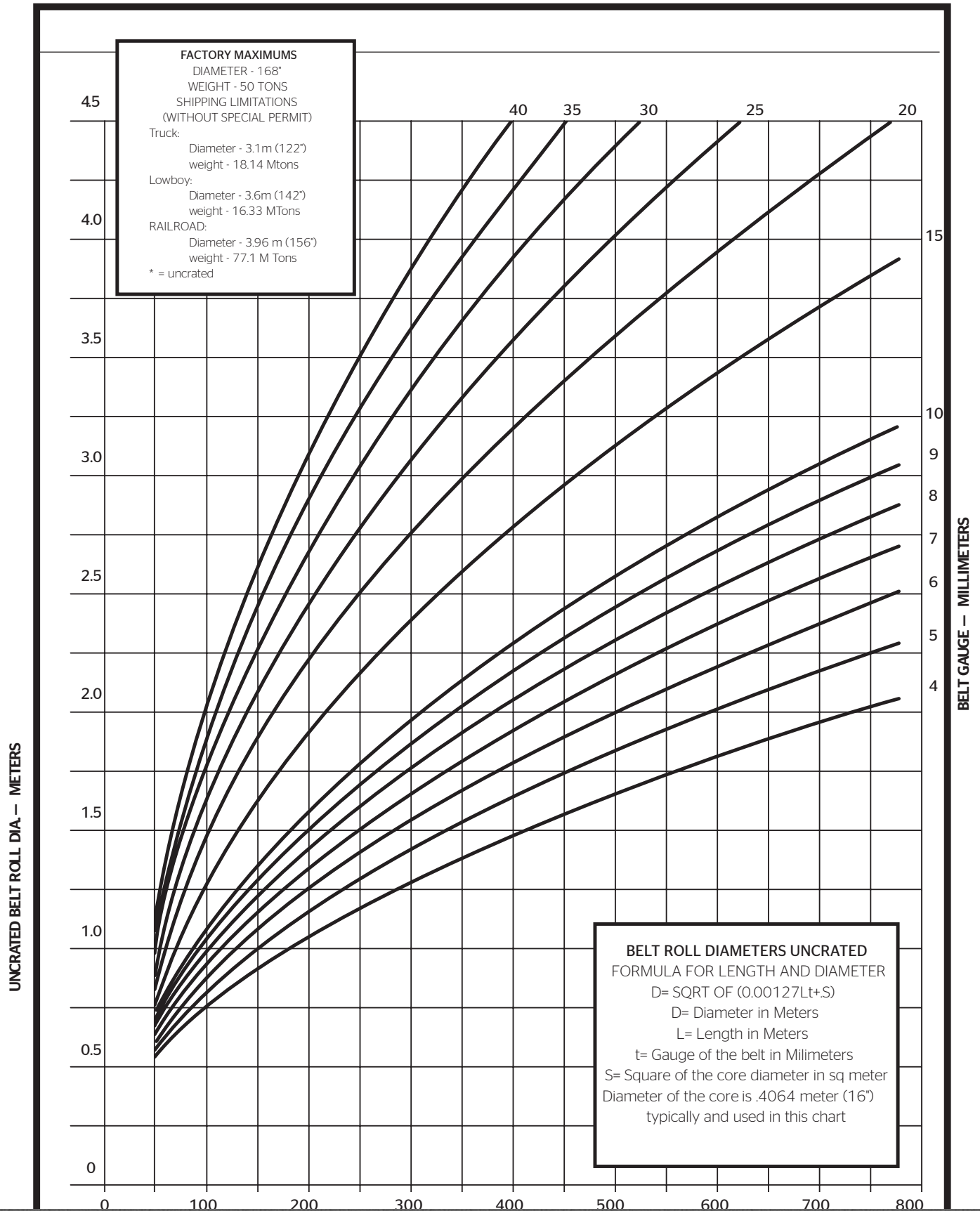

Call Toll Free: 1-866-711-4673
International: +1-727-342-5086



ContiTech



Contact

ContiTech
NAFTA Headquarters
703 S. Cleveland Massillon Road
Fairlawn, OH 44333-3023 U.S.A.
1-800-235-8872

Canada

1-800-263-7788
FAX 1-888-464-4397

Germany

+49 (0)511 938 02
mailservice@contitech.de

www.contitech.us

ContiTech. Engineering Next Level

As a division of the Continental Group, ContiTech is a recognized innovation and technology leader in natural rubber and plastics. As an industry partner with a firm future ahead of us, we engineer solutions both with and for our customers around the world. Our bespoke solutions are specially tailored to meet the needs of the market. With extensive expertise in materials and processes, we are able to develop cutting-edge technologies while ensuring we make responsible use of resources. We are quick to respond to important technological trends, such as function integration, lightweight engineering and the reduction of complexity, and offer a range of relevant products and services. That way, when you need us, you'll find we're already there.

Continental



Continental

The content of this publication is not legally binding and is provided as information only. The trademarks displayed in this publication

721

GOODYEAR
GOODYEARBELTING.COM

Call Toll Free: 1-866-711-4673
International: + 1-727-342-5086

**We Ship
World Wide**