

GOODYEAR RUBBER PRODUCTS

GOODYEAR

RUBBER PRODUCTS

INC.



CENTRAL AVENUE OFFICES
AND SHOWROOM

2014 CONVEYOR BELT



FIRST AVENUE WAREHOUSES

RUBBER & PLASTIC PRODUCTS

For Home & Industry

1-800-FOR-HOSE (367-4673)

GOODYEAR RUBBER PRODUCTS INC.

1912 Central Avenue, St. Petersburg, FL 33712
(727) 822-4672 • FAX (727) 821-8721 • (800) 367-4673
Immediate Delivery From St. Petersburg Warehouses!

1-800-FOR-HOSE

Now Six Locations To Serve You!

CLEARWATER

12330 - 49th Street No.
Clearwater, FL 33762
(727) 573-7745
Fax (727) 573-7752

FORT MYERS

12701 Metro Parkway
Ft. Myers, FL 33966
(239) 561-HOSE(4673)
Fax (239) 561-0018

BRADENTON

6216 - 28th Street East
Bradenton, FL 34203
(941) 739-9777
Fax (941) 739-9778

TAMPA

5910 Adamo Drive (Hwy 60)
Tampa, FL 33619
(813) 627-8956
Fax (813) 627-8957

ST. PETERSBURG

1912 Central Avenue
St. Petersburg, FL 33712
(727) 822-4672 • (800) 367-4673
Fax (727) 821-8721

NAPLES

5530 Shirley St.
Naples, FL 34109
(239) 596-0072
Fax (239) 596-0073

See Locator Maps On Back Cover

GOODYEAR
GOODYEARBELTING.COM

Call Toll Free: 1-866-711-4673
International: +1-727-342-5086

**We Ship
World Wide**



GOODYEAR
GOODYEARBELTING.COM

Call Toll Free: 1-866-711-4673
International: +1-727-342-5086

**We Ship
World Wide**



QUALITY

NOTHING SHIPS FROM OUR ISO-CERTIFIED FACILITIES WITHOUT BEING INSPECTED – TWICE. FIRST WE INSPECT THE RAW MATERIAL, AND THEN WE INSPECT THE FINISHED PRODUCT.

TOUGH

WE BUILD OUR BELTS TOUGH. OUR HEAVY-DUTY AND LIGHTWEIGHT BELTS ARE DESIGNED TO THRIVE IN EXTREME CONDITIONS AND DEMANDING APPLICATIONS.

PROVEN

OUR HIGHLY ENGINEERED BELTS ARE FIELD-PROVEN. THEY'RE TESTED AND TESTED AGAIN TO ENSURE THEY EXCEED OEM STANDARDS.

SMART

EVERYTHING WE SELL TODAY IS ENGINEERED TO GO THE EXTRA MILE. BECAUSE EFFICIENCY IS SMART.

GOODYEAR
GOODYEARBELTING.COM

Call Toll Free: 1-866-711-4673
International: +1-727-342-5086

We Ship
World Wide



TABLE OF CONTENTS

Product Directory	8
Lightweight Belting.....	13
Heavy-Duty Belting.....	43
Lacing	51
Fabrication	57
Accessories	73
Cut & Molded Products.....	79
Reference Charts	85
Worksheets.....	91

GOODYEAR
GOODYEARBELTING.COM

Call Toll Free: 1-866-711-4673
International: + 1-727-342-5086

We Ship
World Wide

**DESCRIPTION
ABBREVIATION
KEY**

EXW = Unique Sign Wave Cover

FR = Fire Retardant

MOR = Moderate Oil Resistance

PVC = Poly Vinyl Chloride

PVGE = Poly Vinyl Grain Elevator

RMV = Rubber Modified Vinyl

SBR = Styrene Butadiene Rubber

SC = Static Conductive

PRODUCT DIRECTORY

LIGHTWEIGHT BELTING			
SPEC #	PART #	DESCRIPTION	PAGE #
FOOD HANDLING			
3800	20103800	2-Ply 100# Polyester White Urethane Bare x Bare	14
3801	20103801	2-Ply 100# Polyester White RMV Cover x Friction	14
3804	20103804	3-Ply 100# Polyester White RMV Cover x Friction	14
3806	20103806	2-Ply 100# Polyester Monofilament White RMV Bare x Bare	14
3805	20103805	2-Ply 100# Polyester Monofilament White RMV Cover x Bare	15
3815	20103815	3-Ply 150# Polyester Monofilament White RMV Cover x Bare	15
3828	20103828	2-Ply 100# Cotton/Polyester White RMV Cotton Top x Bare	15
3822	20103822	2-Ply 100# Polyester Monofilament White RMV Quad Cover x Bare	15
3821	20103821	2-Ply 80# Polyester Monofilament White RMV Pebbletop Cover x Bare	15
3870	20103870	2-Ply 100# Polyester White RMV Pebbletop Cover x Friction	15
3871	20103871	3-Ply 150# Polyester White RMV Pebbletop Cover x Friction	15
3873	20103873	2-Ply 100# Polyester White RMV Meat-Cleat Cover x Friction	16
3840	20103840	1-Ply 34# Polyester Monofilament White Urethane Cover x Bare	16
3841	20103841	2-Ply 65# Polyester Monofilament White Urethane Cover x Bare	16
3859	20103859	2-Ply 75# Polyester Monofilament White Urethane Cover x Bare Anti-static	16
3839	20103839	2-Ply 100# Polyester White Urethane Cover x Bare	16
3854	20103854	2-Ply 100# Polyester Monofilament Blue Urethane Matte Cover x Rice pattern	16
3855	20103855	2-Ply 100# Polyester Monofilament Blue Urethane Matte Cover x Bare Anti-static	16
3851	20103851	2-Ply 100# Polyester Monofilament White Urethane Cover x Quad	17
3852	20103852	2-Ply 65# Polyester Blue Urethane Cover x Bare (Non Fray)	17
3853	20103853	2-Ply 65# Polyester White Urethane Cover x Bare (Non Fray)	17
3880	20103880	2-Ply 100# Polyester Monofilament White Urethane Silicone Cover x Bare	17
5111	20105111	Interwoven 90# Polyester White PVC Cover x Friction	17
5102	20105102	Interwoven 120# Polyester White PVC Cover x Friction	17
5104	20105104	Interwoven 150# Polyester White PVC Cover x Friction	17
5109	20105109	Interwoven 350# Polyester White PVC Cover x Cover	18
5106	20105106	Interwoven 120# Polyester White PVC Chevron Top x Friction	18
5127	20105127	Interwoven 120# Polyester White PVC Crescent Top x Friction	18
5110	20105110	Interwoven 120# Polyester White PVC Roughtop x Friction	18
4002	20104002	3-Ply 70# Polyester White Nitrile Friction x Friction	18
4016	20104016	2-Ply 100# Polyester White Nitrile Cover x Friction	19
4017	20104017	3-Ply 105# Polyester White Nitrile Cover x Friction	19
4013	20104013	3-Ply 150# Polyester White Nitrile Cover x Friction	19
4052	20104052	2-Ply 100# Polyester White Nitrile Heavy Cover x Friction	19
4053	20104053	3-Ply 150# Polyester White Nitrile Heavy Cover x Friction	19
67B	20038509	2-Ply 220# Polyester White PVGE 1/16 Cover x 1/16 Cover	19
4015	20104015	3-Ply 150# Polyester/Nylon Tan Nitrile Cover x Friction	19
4063	20104063	3-Ply 150# Polyester White Nitrile Impression Cover x Impression Cover	20
4023	20104023	3-Ply 105# Polyester White Butyl Cover x Friction	20
4025	20104025	3-Ply 90# Polyester White Nitrile Teflon® Cover x Friction	20
4040	20104040	3-Ply 150# Polyester White Meat-Cleat Cover x Friction	20
4042	20104042	2-Ply 70# Polyester White Nitrile Tyler Wire Cover x Friction	20
4043	20104043	3-Ply 105# Polyester White Nitrile Tyler Wire Cover x Friction	20
4044	20104044	2-Ply 90# Polyester White Nitrile Cone-Top Cover x Friction	20
VOLTA FOOD HANDLING			
2002	20102002	Volta FHW-1.5 Homogeneous Cream Polyester Smooth x Smooth	21
2003	20102003	Volta FHW-2 Homogeneous Cream Polyester Smooth x Smooth	21
2004	20102004	Volta FHW-3 Homogeneous Cream Polyester Smooth x Smooth	21

SPEC #	PART #	DESCRIPTION	PAGE #
VOLTA FOOD HANDLING CONTINUED			
2010	20102010	Volta FMW-2 Homogeneous Cream TPE Smooth x Smooth	22
2016	20102016	Volta FMW-2.5 Homogeneous Cream TPE Smooth x Smooth	22
2011	20102011	Volta FMW-3 Homogeneous Cream TPE Smooth x Smooth	22
2012	20102012	Volta FMW-4 Homogeneous Cream TPE Smooth x Smooth	22
2013	20102013	Volta FMW-5 Homogeneous Cream TPE Smooth x Smooth	22
2008	20102008	Volta FHB-2 Homogeneous Blue Polyester Smooth x Smooth	22
2017	20102017	Volta FHB-3 Homogeneous Blue Polyester Smooth x Smooth	22
2014	20102014	Volta FMB-2 Homogeneous Blue TPE Smooth x Smooth	22
2015	20102015	Volta FMB-3 Homogeneous Blue TPE Smooth x Smooth	22
2018	20102018	Volta FMB-4 Homogeneous Blue TPE Smooth x Smooth	22
2019	20102019	Volta FMB-5 Homogeneous Blue TPE Smooth x Smooth	22
2026	20102026	Volta FELB-2 Homogeneous Blue TPE Smooth x Embossed	23
2036	20102036	Volta FEMB-2 Homogeneous Blue TPE Smooth x Embossed	23
2061	20102061	Volta FRMW-2.5 Homogeneous Cream TPE Smooth x Fabric Back	23
2062	20102062	Volta FRMW-3 Homogeneous Cream TPE Smooth x Fabric Back	23
2033	20102033	Volta FEMW-2.5 ITO-50 Homogeneous Cream TPE Impression x Embossed	23
2038	20102038	Volta FELW-3 ITO-50 Homogeneous Cream TPE Impression x Embossed	23
2090	20102090	Volta FRMW-2.5 ITO-50 Homogeneous Cream TPE Impression x Fabric Back	23
2039	20102039	Volta FEMB-3 CT Homogeneous Blue TPE Crescent x Embossed	23
2040	20102040	Volta FMB-3 CT Homogeneous Blue TPE Crescent x Smooth	23
2034	20102034	Volta FEMB-4 IRT Homogeneous Blue TPE Rooftop x Embossed	24
2035	20102035	Volta FEMB-3.5 IRT Homogeneous Blue TPE Rooftop x Embossed	24
2024	20102024	Volta FEMB-3 SP Homogeneous Blue TPE Spike x Embossed	24
2025	20102025	Volta FELB-3 SP Homogeneous Blue TPE Spike x Embossed	24
2027	20102027	Volta FELB-2.5 MC Homogeneous Blue TPE Meat-Cleat x Embossed	24
2037	20102037	Volta FEMB-3 MC Homogeneous Blue TPE Meat-Cleat x Embossed	24
2032	20102032	Volta FRLB-2 CEB-B Homogeneous Blue TPE Smooth x Covered	24
2041	20102041	Volta FRMB-3 CEB-B Homogeneous Blue TPE Smooth x Covered	24
VOLTA POSITIVE DRIVE			
2050	20102050	Volta FMB-2.5 DDSP Homogeneous Blue TPE Smooth x DualDrive Small Pulley	25
2060	20102060	Volta FMB-3 DD Homogeneous Blue TPE Smooth x DualDrive	25
2056	20102056	Volta FMW-3 DD Homogeneous Cream TPE Smooth x DualDrive	26
2064	20102064	Volta FMB-3 DD ITO-50 Homogeneous Blue TPE Impression x DualDrive	26
2080	20102080	Volta FMB-3 SD Homogeneous Blue TPE Smooth x SuperDrive™	26
2081	20102081	Volta FMB-4 SD Homogeneous Blue TPE Smooth x SuperDrive™	26
2086	20102086	Volta FHB-3 SD Homogeneous Blue Polyester Smooth x SuperDrive™	26
2087	20102087	Volta FHB-4 SD Homogeneous Blue Polyester Smooth x SuperDrive™	26
2082	20102082	Volta FMW-3 SD Homogeneous Cream TPE Smooth x SuperDrive™	26
2083	20102083	Volta FMW-4 SD Homogeneous Cream TPE Smooth x SuperDrive™	26
2088	20102088	Volta FHW-3 SD Homogeneous Cream Polyester Smooth x SuperDrive™	26
2089	20102089	Volta FHW-4 SD Homogeneous Cream Polyester Smooth x SuperDrive™	26
VOLTA GENERAL CONVEYING			
2022	20102022	Volta FRG-2 Homogeneous Gray TPE Smooth x Fabric Back	27
2023	20102023	Volta FRG-3 Homogeneous Gray TPE Smooth x Fabric Back	27
2105	20102105	Volta FEZ-2 Homogeneous Green TPE Smooth x Embossed	27
2106	20102106	Volta FEZ-2.5 Homogeneous Green TPE Smooth x Embossed	27
2107	20102107	Volta FEZ-3.2 Homogeneous Green TPE Smooth x Embossed	27
2108	20102108	Volta FEZ-4 Homogeneous Green TPE Smooth x Embossed	27
2113	20102113	Volta FRGZ-3 Homogeneous Green TPE Smooth x Fabric Back	28
PACKAGE HANDLING			
3808	20103808	2-Ply 100# Spun Polyester Green RMV Matte Cover x Matte Cover	28
4101	20104101	3-Ply 42# Cotton/Polyester Brown Nitrile Friction x Friction	28
4103	20104103	5-Ply 70# Cotton/Polyester Brown Nitrile Friction x Friction	28

**VOLTA
ABBREVIATION
KEY**

B = Blue

CEB-B = Cover
Embossed Bottom

CT = Crescent Top

DD = DualDrive

DDSP = DualDrive
Small Pulley

E = Embossed

F = Flat

G = Gray

H = Hard
Durometer
(Polyester
Compound)

ITO-50 =
Impression Top

IRT = Rooftop

L = Light
Durometer (TPE
Compound)

M = Medium
Durometer (TPE
Compound)

MC = Meat-Cleat

R = Reinforced

SD =
SuperDrive™

SP = Spike Top

TPE =
Thermoplastic
Elastomers

W = White/Cream

Z = Dark Green

**DESCRIPTION
ABBREVIATION
KEY**

EXW = Unique
Sign Wave Cover

FR = Fire
Retardant

HS&W = Hot
Stock and Water

MOR = Moderate
Oil Resistance

PVC = Poly Vinyl
Chloride

RMV = Rubber
Modified Vinyl

SBR = Styrene
Butadiene Rubber

SC = Static
Conductive

SPEC #	PART #	DESCRIPTION	PAGE #
PACKAGE HANDLING CONTINUED			
4109	20104109	4-Ply 200# Spun Polyester Black PVC Friction x Brushed	29
4110	20104110	3-Ply 90# Cotton/Polyester Tan SBR Transmission Friction x Friction	29
4111	20104111	4-Ply 140# Cotton/Polyester Tan SBR Transmission Friction x Friction	29
4112	20104112	4-Ply 200# Polyester/Nylon Black Nitrile 3/32 Cover x Bare	29
4131	20104131	3-Ply 150# Polyester/Nylon Black Nitrile Cover x Friction	29
4136	20104136	Needled 120# Polyester Black PVC Friction x Brushed	29
4113	20104113	4-Ply 200# Polyester Black Nitrile Friction x Friction	29
4115	20104115	3-Ply 105 # Cotton/Polyester Black SBR Transmission Friction x Friction	30
4116	20104116	4-Ply 140# Cotton/Polyester Black SBR Transmission Friction x Friction	30
4117	20104117	3-Ply 105# Cotton/Polyester Hot Stock and Water Cotton x Friction	30
4118	20104118	4-Ply 140# Cotton/Polyester Hot Stock and Water Cotton x Friction	30
4119	20104119	3-Ply 105# Cotton/Polyester White SBR Hot Stock & Water Silicone Cover x Friction	30
4127	20104127	2-Ply 100# Polyester Monofilament Black PVC Bare x Bare	30
4130	20104130	3-Ply 100# Polyester Monofilament Black PVC Bare x Bare	30
4129	20104129	4-Ply 90# Sliptop Polyester Tan Nitrile Bare Nylon x Friction	31
4142	20104142	2-Ply 100# Spun Polyester Black RMV Cover x Friction	31
4143	20104143	3-Ply 150# Spun Polyester Black RMV Cover x Friction	31
4145	20104145	2-Ply 100# Polyester Black PVC D-Impression Cover x Bare	31
4137	20104137	2-Ply 100# Polyester Monofilament Black RMV Cover x Bare	31
4173	20104173	3-Ply 150# Polyester Monofilament Black RMV Cover x Bare	31
4140	20104140	2-Ply 60# Polyester Monofilament Black PVC Matte Cover x Bare Checkout	31
4134	20104134	2-Ply 100# Polyester Monofilament Green PVC Heavy Cover x Bare	32
4133	20104133	3-Ply 150# Polyester Monofilament Green PVC Heavy Cover x Bare	32
4138	20104138	2-Ply 100# Polyester Monofilament Green PVC Cover x Bare Anti-static	32
4149	20104149	2-Ply 100# Polyester Monofilament Green Urethane Cover x Bare	32
4153	20104153	2-Ply 100# Polyester Monofilament Clear PVC Hard Cover x Bare	32
4152	20104152	2-Ply 100# Polyester Monofilament Clear Urethane Cover x Bare Anti-static	32
4148	20104148	2-Ply 100# Polyester Monofilament Clear Urethane Pebbletop x Bare Anti-static	32
4150	20104150	2-Ply 150# Spun Polyester Clear Urethane Cover x Friction	33
90	24005272	Interwoven 90# Polyester Red Urethane Cover x Brushed (Novex)	33
4151	20104151	Interwoven 120# Polyester Red Urethane Cover x Brushed	33
4176	20104176	Interwoven 200# Polyester Red Urethane Cover x Brushed	33
4154	20104154	Needled 135# Polyester Green Nitrile Friction x Brushed	33
4180	20104180	Needled 135# Polyester Black Nitrile Friction x Brushed	33
4174	20104174	2-Ply 150# Polyester Gray Butyl Teflon® Cover x Bare	33
PVC BELTING			
5040	20105040	Interwoven 120# Polyester Black PVC Friction x Brushed	34
5045	20105045	Interwoven 120# Polyester Black PVC Cover x Brushed	34
5042	20105042	Interwoven 120# Polyester Black PVC Cover x Cover	34
5050	20105050	Interwoven 150# Polyester Black PVC Friction x Brushed	34
5051	20105051	Interwoven 150# Polyester Black PVC Cover x Brushed	34
5052	20105052	Interwoven 150# Polyester Black PVC Cover x Cover	34
5060	20105060	Interwoven 200# Polyester Black PVC Friction X Brushed	35
5061	20105061	Interwoven 200# Polyester Black PVC Cover x Brushed	35
5062	20105062	Interwoven 200# Polyester Black PVC Cover x Cover Fire Retardant/Static Conductive	35
5065	20105065	Interwoven 250# Polyester Black PVC Cover x Cover Fire Retardant/Static Conductive	35
5072	20105072	Interwoven 350# Polyester Black PVC Cover x Cover Fire Retardant/Static Conductive	35
73	20040009	Interwoven 450# Polyester Black PVC Cover x Cover Fire Retardant/Static Conductive	35
4144	20104144	2-Ply 150# Polyester Black PVC Matte Cover x Brushed	36
4146	20104146	2-Ply 150# Polyester Black PVC Matte Cover x Matte Cover	36
4324	20104324	Interwoven 120# Polyester Black PVC Chevron Top x brushed	36
4338	20104338	Interwoven 200# Polyester Black PVC Chevron Top x Brushed	36
4327	20104327	Interwoven 120# Polyester Black PVC Crescent Top x Brushed	36
185	20035530	Interwoven 200# Polyester Black PVC Crescent Top x Brushed	36
4329	20104329	Interwoven 120# Polyester Black PVC Z-Top x Brushed	36
4328	20104328	2-Ply 100# Polyester Monofilament Black PVC V-Runner x Bare	37
4340	20104340	Needled 120# Polyester Black PVC V-Runner x Brushed	37
4326	20104326	2-Ply 100# Polyester Monofilament Gray PVC V-Runner x Bare	37
4162	20104162	2-Ply 90# Polyester Monofilament Gray PVC Snake Skin Sticky Top x Bare	37
4160	20104160	2-Ply 65# Polyester Monofilament Gray PVC Smooth Sticky Top x Bare	37

SPEC #	PART #	DESCRIPTION	PAGE #
INCLINE BELTING			
4301	20104301	2-Ply 150# Polyester Black SBR Roughtop x Bare	38
4302	20104302	3-Ply 105# Cotton/Polyester Black SBR Roughtop x Bare	38
4303	20104303	2-Ply 150# Polyester Tan SBR Roughtop x Bare	38
4304	20104304	2-Ply 150# Polyester Tan Natural Rubber Roughtop x Bare	39
4305	20104305	3-Ply 225# Polyester Tan Natural Rubber Roughtop x Bare	39
4307	20104307	3-Ply 150# Polyester Blue Carboxylated Nitrile Roughtop x Friction	39
4377	20104377	3-Ply 150# Polyester/Nylon Blue Carboxylated Nitrile Roughtop x Bare	39
4330	20104330	2-Ply 90# Multifilament Blue Carboxylated Nitrile Roughtop x Bare	39
4360	20104360	3-Ply 225# Polyester Red Carboxylated Nitrile Roughtop x Bare	39
4309	20104309	3-Ply 150# Polyester/Nylon Orange Carboxylated Nitrile Roughtop x Bare	39
4308	20104308	3-Ply 150# Polyester/Nylon Brown Nitrile Roughtop x Bare	40
4351	20104351	3-Ply 150# Polyester Tan Nitrile Roughtop x Friction	40
4321	20104321	Interwoven 120# Polyester Black PVC Roughtop x Friction	40
61B	20035509	Interwoven 150# Polyester Black PVC Roughtop x Friction	40
4391	20104391	Interwoven 120# Polyester Black PVC Roughtop x Brushed	40
4322	20104322	Interwoven 120# Polyester Green PVC Extra Grip Roughtop x Bare	40
4357	20104357	Interwoven 170# Polyester Red PVC Roughtop x Friction	40
4346	20104346	2-Ply 100# Polyester Monofilament Green PVC Roughtop x Bare	41
4350	20104350	2-Ply 100# Polyester Monofilament Green PVC EXW Roughtop x Bare	41
4310	20104310	3-Ply 150# Polyester/Nylon Brown Nitrile V-Top x Friction	41
4311	20104311	3-Ply 150# Polyester/Nylon Tan Pure Gum V-Top x Friction	41
4312	20104312	3-Ply 105# Cotton/Polyester Black SBR V-Top x Friction	41
4313	20104313	2-Ply 150# Polyester Tan SBR Siped Diamond Top x Bare	41
4374	20104374	3-Ply 240# Polyester Tan SBR Diamond Top x Bare	41
4314	20104314	2-Ply 150# Polyester Black SBR Siped Diamond Top x Bare	42
4375	20104375	3-Ply 225# Polyester Black SBR Diamond Top x Bare	42
4315	20104315	3-Ply 90# Cotton/Polyester Tan Natural Rubber Steep-Grade x Friction	42
4317	20104317	2-Ply 150# Polyester Black SBR Steep-Grade x Bare	42
4334	20104334	3-Ply 90# Cotton/Polyester Black SBR Steep-Grade x Friction	42
HEAVY-DUTY BELTING			
INDUSTRIAL BELT			
1	20027202	2-Ply 150# 1/32 x Bare Back Grade 2	44
2	20027301	2-Ply 150# 1/32 x 1/32 Grade 2	44
3	20000010	2-Ply 150# 1/8 x 1/32 Grade 2	44
6A	20029525	2-Ply 220# 1/8 x Bare Back Grade 2	44
8	20013600	2-Ply 220# 1/8 x 1/16 Grade 2	45
9	20017500	2-Ply 220# 3/16 x 1/16 Grade 2	45
11	20023005	3-Ply 330# 3/16 x 1/16 Grade 2	45
12	20026039	3-Ply 330# 1/4 x 1/16 Grade 2	45
13	20026815	4-Ply 440# 1/4 x 1/16 Grade 2	45
15	20017538	2-Ply 400# 5/16 x 1/16 Grade 2	45
246A	20029850	1-Ply 440# 1/4 x 1/8 Grade 1	46
14B	20241012	3-Ply 600# 3/8 x 3/32 Grade 1	46
26C	20029690	2-Ply 220# 1/8 x Bare Back Moderate Oil Resistance	46
GRAIN BELT			
21	20027200	2-Ply 150# 1/32 x Bare Back Moderate Oil Resistance	46
25A	20021630	3-Ply 330# 1/16 x 1/16 Static Conductive Oil Resistant Fire Retardant Grain	46
27A	20021635	3-Ply 600# 1/16 x 1/16 Static Conductive Oil Resistant Fire Retardant Grain	46
SPECIAL SERVICE BELT			
24B	20017332	2-Ply 220# 3/16 x 1/16 Moderate Oil Resistance	47
26A	20021820	3-Ply 330# 3/16 x 1/16 Moderate Oil Resistance	47
26B	20029734	3-Ply 330# 3/16 x Bare Back Moderate Oil Resistance	47
41	20021199	2-Ply 220# 3/16 x 1/16 400° Maxi-Heat	47
41A	20021237	2-Ply 220# 3/16 x 1/16 700° Super-Heat	47

**DESCRIPTION
ABBREVIATION
KEY**

EXW = Unique Sign Wave Cover

FR = Fire Retardant

HS&W = Hot Stock and Water

MOR = Moderate Oil Resistance

PVC = Poly Vinyl Chloride

RMV = Rubber Modified Vinyl

SBR = Styrene Butadiene Rubber

SC = Static Conductive

**DESCRIPTION
ABBREVIATION
KEY**

EXW = Unique
Sign Wave Cover

FR = Fire
Retardant

MOR = Moderate
Oil Resistance

PVC = Poly Vinyl
Chloride

RMV = Rubber
Modified Vinyl

SBR = Styrene
Butadiene Rubber

SC = Static
Conductive

SPEC #	PART #	DESCRIPTION	PAGE #
MOLDED CHEVRON BELT			
43A	20026790	3-Ply 330# 1/4 x 1/16 700° Super-Heat	48
57A	20029603	2-Ply 220# 1/8 x 1/16 Durocleat™ Grade 2	49
58	20029601	2-Ply 220# 1/8 x 1/16 Durocleat™ Moderate Oil Resistance	49
178	20029605	3-Ply 330# 1/8 x 1/16 Durocleat™ Grade 2	49
59B	20029615	3-Ply 330# 1/8 x 1/16 Durocleat™ Moderate Oil Resistance	49
56B	20029602	2-Ply 220# 1/8 x Bare Back Durocleat™ Moderate Oil Resistance	49
247	20029607	3-Ply 330# 1/8 x Bare Back Durocleat™ Moderate Oil Resistance	49
281	20029620	2-Ply 220# 5/8 x 16 Durochev™ Molded Chevron Cleat	50
103B	20029575	2-Ply 220# Continuous Chevron Top x Bare Back	50

BELT CONSTRUCTION

We offer the industry's broadest range of lightweight belting specifications and fabricated products:

- ▶ Interwoven polyester with PVC and polyurethane covers
- ▶ European-style PVC and polyurethane, with spun polyester and polyester monofilament carcasses to fit specific application needs
- ▶ Conventional rubber
- ▶ Profile top covers for all incline needs
- ▶ Textured bottom covers for additional gripping power on pulleys

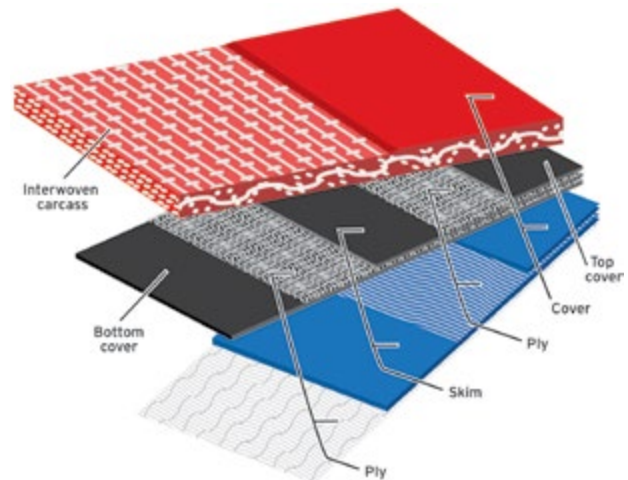

**FOOD
HANDLING**



SPEC#	PART#	TEMP.	THICKNESS	WEIGHT (PIW)	MIN. PULLEY	ACCEPTED	RECOMMENDED LACING
2-PLY 100# POLYESTER WHITE URETHANE BARE X BARE							
3800	20103800	0°F to 180°F	0.078"	0.040	1"	FDA, EU	UCM36-SP Clipper®, #1A Alligator®, #62 Staple

This belt provides excellent service in a wide variety of food processing applications. The urethane-impregnated surface makes it a popular choice for rolling and forming, as well as some cutting and packing applications. Urethane skim prevents delamination and provides excellent splicing strength and appearance. Strong with the flexibility required in today's food processing applications.

**DESCRIPTION
ABBREVIATION
KEY**

RMV = Rubber
Modified Vinyl



SPEC#	PART#	TEMP.	THICKNESS	WEIGHT (PIW)	MIN. PULLEY	ACCEPTED	RECOMMENDED LACING
2-PLY 100# POLYESTER WHITE RMV COVER X FRICTION							
3801	20103801	0°F to 180°F	0.109"	0.050	2"	FDA	UX1 Clipper®, #7 Alligator®, #125 Staple
3-PLY 100# POLYESTER WHITE RMV COVER X FRICTION							
3804	20103804	0°F to 180°F	0.14"	0.080	4"	FDA	U2 Clipper®, #15 Alligator®, #187 Staple

Constructed with multiple plies of spun polyester, this carcass provides great tracking, with excellent strength and lace holding ability. A premium, lightweight product that is extremely versatile.



SPEC#	PART#	TEMP.	THICKNESS	WEIGHT (PIW)	MIN. PULLEY	ACCEPTED	RECOMMENDED LACING
2-PLY 100# POLYESTER MONOFILAMENT WHITE RMV BARE X BARE							
3806	20103806	0°F to 180°F	0.062"	0.035	1"	FDA, EU	UCM36 Clipper®, #7 Alligator®, #62 Staple

This belt features an RMV-impregnated polyester monofilament carcass that offers superior service in many applications where it is critical the belt lay flat. The fabric provides great flexibility, reduced belt loading due to low friction, and superior belt tracking. Can be easily spliced endless and is available with a full range of fabrications.

DESCRIPTION ABBREVIATION KEY

RMV = Rubber Modified Vinyl

SPEC#	PART#	TEMP.	THICKNESS	WEIGHT (PIW)	MIN. PULLEY	ACCEPTED	RECOMMENDED LACING
2-PLY 100# POLYESTER MONOFILAMENT WHITE RMV COVER X BARE							
3805	20103805	0°F to 180°F	0.093"	0.050	1"	FDA, EU	UX1SP Clipper®, #7 Alligator®, #62 Staple
3-PLY 150# POLYESTER MONOFILAMENT WHITE RMV COVER X BARE							
3815	20103815	0°F to 180°F	0.172"	0.090	4"	FDA, EU	U2 Clipper®, #15 Alligator®, #187 Staple



This belt features an RMV-impregnated polyester monofilament carcass that offers superior service in many applications where it is critical the belt lay flat. The fabric provides great flexibility, reduced belt loading due to low friction, and superior belt tracking. Can be easily spliced endless and is available with a full range of fabrications.

SPEC#	PART#	TEMP.	THICKNESS	WEIGHT (PIW)	MIN. PULLEY	ACCEPTED	RECOMMENDED LACING
2-PLY 100# COTTON/POLYESTER WHITE RMV COTTON TOP X BARE							
3828	20103828	0°F to 180°F	0.109"	0.040	1"	FDA	UX1SP Clipper®, #7 Alligator®, #62 Staple



This high-quality synthetic cotton belt is increasingly popular as a replacement to solid woven cotton belting. This is especially true in bread, cracker and pretzel manufacturing. Combining the proven performance of cotton fiber and polyester monofilament construction, these belts can be finger spliced for a smooth, strong and flexible splice.

SPEC#	PART#	TEMP.	THICKNESS	WEIGHT (PIW)	MIN. PULLEY	ACCEPTED	RECOMMENDED LACING
2-PLY 100# POLYESTER MONOFILAMENT WHITE RMV QUAD COVER X BARE							
3822	20103822	0°F to 180°F	0.093"	0.042	1"	FDA, EU	UX1SP Clipper®, #7 Alligator®, #62 Staple

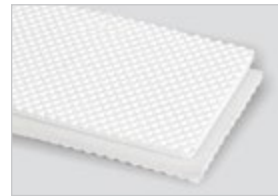

Used in many food packaging, bakery and candy applications. Light oil resistance makes these belts an option for some industrial applications as well. Because these products are thermoplastic, they can be easily finger spliced.

SPEC#	PART#	TEMP.	THICKNESS	WEIGHT (PIW)	MIN. PULLEY	ACCEPTED	RECOMMENDED LACING
2-PLY 80# POLYESTER MONOFILAMENT WHITE RMV PEBBLETOP COVER X BARE							
3821	20103821	0°F to 180°F	0.078"	0.030	1"	FDA	UX1 Clipper®, #7 Alligator®, #62 Staple



Used in many food packaging, bakery and candy applications. Light oil resistance makes these belts an option for some industrial applications as well. Because these products are thermoplastic, they can be easily finger spliced.

SPEC#	PART#	TEMP.	THICKNESS	WEIGHT (PIW)	MIN. PULLEY	ACCEPTED	RECOMMENDED LACING
2-PLY 100# POLYESTER WHITE RMV PEBBLETOP COVER X FRICTION							
3870	20103870	0°F to 180°F	0.125"	0.060	2"	FDA	UX1 Clipper®, #7 Alligator®, #125 Staple
3-PLY 150# POLYESTER WHITE RMV PEBBLETOP COVER X FRICTION							
3871	20103871	0°F to 180°F	0.187"	0.090	4"	FDA	U2 Clipper®, #15 Alligator®,



Call Toll Free: 1-866-711-4673
International: +1-727-342-5086



DESCRIPTION
ABBREVIATION
KEY

RMV = Rubber
Modified Vinyl



SPEC#	PART#	TEMP.	THICKNESS	WEIGHT (PIW)	MIN. PULLEY	ACCEPTED	RECOMMENDED LACING
2-PLY 100# POLYESTER WHITE RMV MEAT-CLEAT COVER X FRICTION							
3873	20103873	0°F to 180°F	0.25"	0.090	2"	FDA	UX1 Clipper®, #7 Alligator®, #125 Staple

Used in many food packaging, bakery and candy applications. Light oil resistance makes these belts an option for some industrial applications as well. Because these products are thermoplastic, they can be easily finger spliced.



SPEC#	PART#	TEMP.	THICKNESS	WEIGHT (PIW)	MIN. PULLEY	ACCEPTED	RECOMMENDED LACING
1-PLY 34# POLYESTER MONOFILAMENT WHITE URETHANE COVER X BARE							
3840	20103840	0°F to 180°F	0.031"	0.011	Nose Bar	FDA, EU	#0 Alligator®
2-PLY 65# POLYESTER MONOFILAMENT WHITE URETHANE COVER X BARE							
3841	20103841	0°F to 180°F	0.062"	0.062	1.5"	FDA, USDA, EU	UCM36SP Clipper®, #7 Alligator®, #62 Staple
2-PLY 75# POLYESTER MONOFILAMENT WHITE URETHANE COVER X BARE ANTI-STATIC							
3859	20103859	0°F to 180°F	0.062"	0.024	1.5"	FDA, USDA	UCM36 Clipper®, #1A Alligator®, #62 Staple

The preferred belting style in most applications in today's food industries, including candy and confectionery, baking, fruit & vegetables, pickles, canning, and meat & poultry processing. The lightweight, low friction bottom make these among the most efficient belts on the market. They are also commonly used in industrial applications when a non-marking or a light-colored, abrasion-resistant belt is required.



SPEC#	PART#	TEMP.	THICKNESS	WEIGHT (PIW)	MIN. PULLEY	ACCEPTED	RECOMMENDED LACING
2-PLY 100# POLYESTER WHITE URETHANE COVER X BARE							
3839	20103839	0°F to 180°F	0.062"	0.024	1.5"	FDA, EU	UCM36SP Clipper®, #1A Alligator®, #62 Staple

The preferred belting style in most applications in today's food industries, including candy and confectionery, baking, fruit & vegetables, pickles, canning, and meat & poultry processing. The lightweight, low friction bottom make these among the most efficient belts on the market. They are also commonly used in industrial applications when a non-marking or a light-colored, abrasion-resistant belt is required.



SPEC#	PART#	TEMP.	THICKNESS	WEIGHT (PIW)	MIN. PULLEY	ACCEPTED	RECOMMENDED LACING
2-PLY 100# POLYESTER MONOFILAMENT BLUE URETHANE MATTE COVER X RICE PATTERN							
3854	20103854	0°F to 180°F	0.071"	0.030	1"	FDA, EU	UCM36SP Clipper®, #1 Alligator®, #62 Staple

This belt has exceptional dimensional stability, and lies perfectly flat. The 100% urethane cover and rice-pattern bottom keep build up to a minimum.

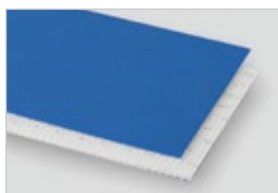

SPEC#	PART#	TEMP.	THICKNESS	WEIGHT (PIW)	MIN. PULLEY	ACCEPTED	RECOMMENDED LACING
2-PLY 100# POLYESTER MONOFILAMENT BLUE URETHANE MATTE COVER X BARE ANTI-STATIC							
3855	20103855	0°F to 180°F	0.071"	0.036	1.57"	FDA, EU	UCM36SP Clipper®, #1 Alligator®, #62 Staple

This belt is used primarily in Z conveyors and food processing applications.

SPEC#	PART#	TEMP.	THICKNESS	WEIGHT (PIW)	MIN. PULLEY	ACCEPTED	RECOMMENDED LACING
2-PLY 100# POLYESTER MONOFILAMENT WHITE URETHANE COVER X QUAD							
3851	20103851	0°F to 180°F	0.083"	0.039	3.9"	FDA, EU	UCM36SP Clipper®, #1 Alligator®, #62 Staple



A premium urethane belt that can be capped with a durable urethane cover, totally sealing the belt carcass from exposure. This belt has a quad impression bottom for improved drive characteristics and a skim urethane bottom surface. With urethane-capped edges, this is an excellent alternative to solid thermoplastic belts, which are prone to stretching.

SPEC#	PART#	TEMP.	THICKNESS	WEIGHT (PIW)	MIN. PULLEY	ACCEPTED	RECOMMENDED LACING
2-PLY 65# POLYESTER BLUE URETHANE COVER X BARE (NON FRAY)							
3852	20103852	0°F to 180°F	0.062"	0.022	.5"	FDA, EU	UCM36SP Clipper®, #1 Alligator®, #62 Staple

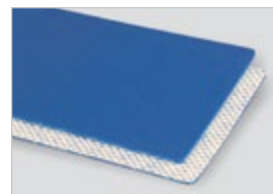

Fast becoming a favorite in the snack food and confectionery industries, this belt offers a unique belt carcass that resists edge fraying.

SPEC#	PART#	TEMP.	THICKNESS	WEIGHT (PIW)	MIN. PULLEY	ACCEPTED	RECOMMENDED LACING
2-PLY 65# POLYESTER WHITE URETHANE COVER X BARE (NON FRAY)							
3853	20103853	0°F to 180°F	0.062"	0.022	.5"	FDA, EU	UCM36SP Clipper®, #1 Alligator®, #62 Staple



Fast becoming a favorite in the snack food and confectionery industries, this belt offers a unique belt carcass that resists edge fraying.

SPEC#	PART#	TEMP.	THICKNESS	WEIGHT (PIW)	MIN. PULLEY	ACCEPTED	RECOMMENDED LACING
2-PLY 100# POLYESTER MONOFILAMENT WHITE URETHANE SILICONE COVER X BARE							
3880	20103880	0°F to 180°F	0.055"	0.040	1"	FDA, EU	UCM36 Clipper®, #1 Alligator®, #62 Staple



Silicone characteristics of this belt give it an easy clean, non-cracking surface for enhanced hygiene, and is non-absorbent with oil and grease resistance. This belt is preferred in a wide variety of applications, especially those involving hot, sticky products requiring good release characteristics.

SPEC#	PART#	TEMP.	THICKNESS	WEIGHT (PIW)	MIN. PULLEY	ACCEPTED	RECOMMENDED LACING
INTERWOVEN 90# POLYESTER WHITE PVC COVER X FRICTION							
5111	20105111	0°F to 180°F	0.093"	0.080	1.5"	FDA, USDA	UX1SP Clipper®, #7 Alligator®, #62 Staple
INTERWOVEN 120# POLYESTER WHITE PVC COVER X FRICTION							
5102	20105102	0°F to 180°F	0.125"	0.103	2.5"	FDA, USDA	UX1 Clipper®, #7 Alligator®, #125 Staple
INTERWOVEN 150# POLYESTER WHITE PVC COVER X FRICTION							
5104	20105104	0°F to 180°F	0.172"	0.090	4"	FDA, USDA	U2 Clipper®, #15 Alligator®, #187 Staple



Popular and versatile belts for a variety of food processing applications. Can wrap small pulleys. FDA approved and USDA accepted.

DESCRIPTION ABBREVIATION KEY

PVC = Poly Vinyl Chloride

DESCRIPTION
ABBREVIATION
KEY

PVC = Poly Vinyl
Chloride



SPEC#	PART#	TEMP.	THICKNESS	WEIGHT (PIW)	MIN. PULLEY	ACCEPTED	RECOMMENDED LACING
INTERWOVEN 350# POLYESTER WHITE PVC COVER X COVER							
5109	20105109	0°F to 180°F	0.313"	0.150	8"	FDA, USDA	#140 Solid Plate, #550 Bolt On, #R5 Rivet

Designed for elevator applications and is a favorite for handling grains, salts and food products. Low stretch carcass and excellent bolt holding ability. FDA approved and USDA accepted.



SPEC#	PART#	TEMP.	THICKNESS	WEIGHT (PIW)	MIN. PULLEY	ACCEPTED	RECOMMENDED LACING
INTERWOVEN 120# POLYESTER WHITE PVC CHEVRON TOP X FRICTION							
5106	20105106	0°F to 180°F	0.25"	0.085	3"	FDA	UX1 Clipper®, #7 Alligator®, #125 Staple

Excellent belt for moving bulk or free flowing materials, such as grains, food stuffs, feeds, and fertilizers up steep inclines. Alternating rows of solid PVC chevrons form a herringbone pattern which returns belt smoothly and quietly. Meets FDA requirements.



SPEC#	PART#	TEMP.	THICKNESS	WEIGHT (PIW)	MIN. PULLEY	ACCEPTED	RECOMMENDED LACING
INTERWOVEN 120# POLYESTER WHITE PVC CRESCENT TOP X FRICTION							
5127	20105127	0°F to 180°F	0.25"	0.096	2.5"	FDA	UX1 Clipper®, #7 Alligator®, #125 Staple

Crescent half-moon shaped profiles project from belt surface to effectively move packaged and bulk materials. The crescent top profile has an overlap design to assure smooth and quiet running on return rolls. Meets FDA requirements.



SPEC#	PART#	TEMP.	THICKNESS	WEIGHT (PIW)	MIN. PULLEY	ACCEPTED	RECOMMENDED LACING
INTERWOVEN 120# POLYESTER WHITE PVC ROUGHTOP X FRICTION							
5110	20105110	0°F to 180°F	0.25"	0.080	3"	FDA	UX1 Clipper®, #7 Alligator®, #125 Staple

Popular rough top profile provides high grip characteristics for moving boxes, packages and cases for both incline and decline applications.



SPEC#	PART#	TEMP.	THICKNESS	WEIGHT (PIW)	MIN. PULLEY	ACCEPTED	RECOMMENDED LACING
3-PLY 70# POLYESTER WHITE NITRILE FRICTION X FRICTION							
4002	20104002	0°F to 250°F	0.093"	0.040	2"	FDA, USDA	UXISP Clipper®, #7 Alligator®, #62 Staple

A light and versatile food-grade belt with traditional white nitrile covers to withstand the effects of oil, grease and fats. Can wrap a 2" diameter pulley. FDA approved and USDA accepted.

SPEC#	PART#	TEMP.	THICKNESS	WEIGHT (PIW)	MIN. PULLEY	ACCEPTED	RECOMMENDED LACING
2-PLY 100# POLYESTER WHITE NITRILE COVER X FRICTION							
4016	20104016	0°F to 250°F	0.078"	0.050	1.5"	FDA, USDA	UX1SP Clipper®, #7 Alligator®, #62 Staple
3-PLY 105# POLYESTER WHITE NITRILE COVER X FRICTION							
4017	20104017	0°F to 250°F	0.109"	0.064	2"	FDA, USDA	UX1 Clipper®, #7 Alligator®, #125 Staple
3-PLY 150# POLYESTER WHITE NITRILE COVER X FRICTION							
4013	20104013	0°F to 250°F	0.14"	0.070	2.5"	FDA, USDA	UX1 Clipper®, #15 Alligator®, #125 Staple



Popular belt for a wide variety of food-grade applications. Nitrile covers offer excellent resistance to oil, grease and fats. FDA approved and USDA accepted.

SPEC#	PART#	TEMP.	THICKNESS	WEIGHT (PIW)	MIN. PULLEY	ACCEPTED	RECOMMENDED LACING
2-PLY 100# POLYESTER WHITE NITRILE HEAVY COVER X FRICTION							
4052	20104052	0°F to 250°F	0.145"	0.055	2"	FDA, USDA	UX1 Clipper®, #15 Alligator®, #125 Staple
3-PLY 150# POLYESTER WHITE NITRILE HEAVY COVER X FRICTION							
4053	20104053	0°F to 250°F	0.196"	0.075	3.5"	FDA, USDA	U3 Clipper®, #25 Alligator®, #187 Staple



Thicker white nitrile top cover to better withstand abuse and with the effects of oil, grease and fats in the tougher applications. FDA approved and USDA accepted.

SPEC#	PART#	TEMP.	THICKNESS	WEIGHT (PIW)	MIN. PULLEY	ACCEPTED	RECOMMENDED LACING
2-PLY 220# POLYESTER WHITE PVGE 1/16 COVER X 1/16 COVER							
67B	20038509	-20°F to 180°F	0.25"	0.126	8"	FDA	#4 Clipper®, #27 Alligator®, #187 Staple



Excellent heavy-duty food-grade belt, ideal for handling bulk foods such as salt, sugar, and grain. Good elevator belt with anti-static properties, and low temperature rating.

SPEC#	PART#	TEMP.	THICKNESS	WEIGHT (PIW)	MIN. PULLEY	ACCEPTED	RECOMMENDED LACING
3-PLY 150# POLYESTER/NYLON TAN NITRILE COVER X FRICTION							
4015	20104015	0°F to 250°F	0.109"	0.064	3"	FDA, USDA	UX1 Clipper®, #7 Alligator®, #125 Staple



Nitrile cover offers excellent resistance to oil, grease and fats. Popular for sorting lines and tomato processing. FDA approved and USDA accepted.

DESCRIPTION ABBREVIATION KEY

PVGE = Poly Vinyl Grain Elevator



SPEC#	PART#	TEMP.	THICKNESS	WEIGHT (PIW)	MIN. PULLEY	ACCEPTED	RECOMMENDED LACING
3-PLY 150# POLYESTER WHITE NITRILE IMPRESSION COVER X IMPRESSION COVER							
4063	20104063	0°F to 250°F	0.264"	1.300	6"	FDA	U3 Clipper®, #25 Alligator®, #187 Staple

This belt is widely accepted in Europe. Though specifically designed for the sugar industry, it has proven to be a problem solver in various applications such as salt mining, cut glass, and chemical compatibility.



SPEC#	PART#	TEMP.	THICKNESS	WEIGHT (PIW)	MIN. PULLEY	ACCEPTED	RECOMMENDED LACING
3-PLY 105# POLYESTER WHITE BUTYL COVER X FRICTION							
4023	20104023	-40°F to 325°F	0.093"	0.053	2"	FDA	UX1 Clipper®, #7 Alligator®, #62 Staple

Excellent temperature range for both freezer and high-heat applications such as packaging, sealer and shrink tunnels.



SPEC#	PART#	TEMP.	THICKNESS	WEIGHT (PIW)	MIN. PULLEY	ACCEPTED	RECOMMENDED LACING
3-PLY 90# POLYESTER WHITE NITRILE TEFLON® COVER X FRICTION							
4025	20104025	0°F to 250°F	0.093"	0.044	3"	FDA, USDA	UX1 Clipper®, #7 Alligator®, #62 Staple

Excellent product for conveying and releasing wet, sticky materials. Popular in bakery and confectionery, as well as industrial applications to handle glues and coatings. FDA approved and USDA accepted.



SPEC#	PART#	TEMP.	THICKNESS	WEIGHT (PIW)	MIN. PULLEY	ACCEPTED	RECOMMENDED LACING
3-PLY 150# POLYESTER WHITE MEAT-CLEAT COVER X FRICTION							
4040	20104040	0°F to 250°F	0.234"	0.072	2"	FDA, USDA	UX1 Clipper®, #7 Alligator®, #125 Staple

Nitrile rubber belt featuring a mini-cleat profile. Used in incline applications involving packaged meat and food processing, as well where a more aggressive top cover is required.



SPEC#	PART#	TEMP.	THICKNESS	WEIGHT (PIW)	MIN. PULLEY	ACCEPTED	RECOMMENDED LACING
2-PLY 70# POLYESTER WHITE NITRILE TYLER WIRE COVER X FRICTION							
4042	20104042	0°F to 250°F	0.093"	0.050	1.5"	FDA, USDA	UCM36 Clipper®, #7 Alligator®, #62 Staple
3-PLY 105# POLYESTER WHITE NITRILE TYLER WIRE COVER X FRICTION							
4043	20104043	0°F to 250°F	0.109"	0.065	2"	FDA, USDA	UX1 Clipper®, #7 Alligator®, #12 Staple

Popular food-grade belt for use in slight inclines and where a textured cover provides better gripping characteristics. FDA approved and USDA accepted.



SPEC#	PART#	TEMP.	THICKNESS	WEIGHT (PIW)	MIN. PULLEY	ACCEPTED	RECOMMENDED LACING
2-PLY 90# POLYESTER WHITE NITRILE CONE-TOP COVER X FRICTION							
4044	20104044	0°F to 250°F	0.218"	0.075	1"	FDA	UCM36 Clipper®, #7 Alligator®, #62 Staple

VOLTA BELTING

Volta belting is tough, versatile, and easy to maintain. The homogeneous, no-ply construction eliminates the need to have edge capping and its non-absorbent material makes the belts bacteria-resistant and impenetrable by most chemicals. These advantages create a belt that performs well in a variety of food processing and general conveying environments.



Positive Drive Belt options are listed on p. 25.

General Conveying Belt specs are listed on p. 27.

VOLTA FOOD BELT

The food processing industry's needs are broad and its requirements are stringent. For such challenging needs, the Apache | Trico Industrial Division recommends the Volta homogeneous product line. These belts perform well in a variety of food processing environments. Cheese, poultry, meat, fish, seafood, fruits, vegetables, chocolates, snacks, potatoes, nuts, and bakery facilities are all great places for recommending this product. Volta belting is available in blue or cream, is FDA/USDA approved, and also 3A Dairy certified.

VOLTA FOOD HANDLING

IN THESE INDUSTRIES YOU WILL FIND A VARIETY OF APPLICATIONS, BUT SOME OF THE MOST POPULAR INCLUDE:

- ▶ Dicing equipment
- ▶ De-boning operations
- ▶ Dough return conveyors
- ▶ Dump and pack tables
- ▶ Inspection lines
- ▶ Knife edge transfer lines
- ▶ Lettuce washing machines
- ▶ Metal detectors
- ▶ Optical scanners
- ▶ Press machines
- ▶ Slicing/filleting applications
- ▶ Vegetable washing lines

Because these applications require a variety of specifications, this product line offers multiple covers and has a variety of fabrication options. The crescent top and spike top are ideal for chicken slicing lines. Cleated sidewall belts can carry any grouping of food product up most inclines. The meat-cleat and IRT (Rooftop) profiles can be used to elevate the product and allow for runoff, as well as to hold the product in place on light inclines. The Volta homogeneous ITO-50 offers a low profile impression.

SPEC#	PART#	TEMP.	PULL FORCE PRETENSION 1%	THICKNESS	WEIGHT (PIW)	MIN. PULLEY	ACCEPTED	RECOMMENDED LACING
VOLTA FHW-1.5 HOMOGENEOUS CREAM POLYESTER SMOOTH X SMOOTH								
2002	20102002	-5°F to 140°F	8.4	1.5 mm	0.030	2"	FDA, USDA, EU, 3A Dairy	UCM36SP Clipper®, #1 Alligator®, #62 Staple
VOLTA FHW-2 HOMOGENEOUS CREAM POLYESTER SMOOTH X SMOOTH								
2003	20102003	-5°F to 140°F	11.2	2 mm	0.040	2.75"	FDA, USDA, EU, 3A Dairy	UX1SP Clipper®, #1 Alligator®, #62 Staple
VOLTA FHW-3 HOMOGENEOUS CREAM POLYESTER SMOOTH X SMOOTH								
2004	20102004	-5°F to 140°F	16.8	3 mm	0.060	3.5"	FDA, USDA, EU, 3A Dairy	UX1SP Clipper®, #15 Alligator®, #125 Staple
VOLTA FHW-4 HOMOGENEOUS CREAM POLYESTER SMOOTH X SMOOTH								
2005	20102005	-5°F to 140°F	22.4	4 mm	0.080	4.375"	FDA, USDA, EU, 3A Dairy	U2 Clipper®, #25 Alligator®, #187 Staple
VOLTA FHW-5 HOMOGENEOUS CREAM POLYESTER SMOOTH X SMOOTH								



VOLTA ABBREVIATION KEY

- B** = Blue
- CEB-B** = Cover Embossed Bottom
- CT** = Crescent Top
- DD** = DualDrive
- DDSP** = DualDrive Small Pulley
- E** = Embossed
- F** = Flat
- G** = Gray
- H** = Hard Durometer (Polyester Compound)
- ITO-50** = Impression Top
- IRT** = Rooftop
- L** = Light Durometer (TPE Compound)
- M** = Medium Durometer (TPE Compound)
- MC** = Meat-Cleat
- R** = Reinforced
- SD** = SuperDrive™
- SP** = Spike Top

Volta Homogeneous Cream Polyester Smooth x Smooth continued from p. 21.

SPEC#	PART#	TEMP.	PULL FORCE PRETENSION 1%	THICKNESS	WEIGHT (PIW)	MIN. PULLEY	ACCEPTED	RECOMMENDED LACING
VOLTA FMW-2 HOMOGENEOUS CREAM TPE SMOOTH X SMOOTH								
2010	20102010	-20°F to 140°F	6.8	2 mm	0.040	1.1875"	FDA, USDA, EU, 3A Dairy	UX1SP Clipper®, #1 Alligator®, #62 Staple
VOLTA FMW-2.5 HOMOGENEOUS CREAM TPE SMOOTH X SMOOTH								
2016	20102016	-20°F to 140°F	8.4	2.5 mm	0.050	1.375"	FDA, USDA, EU, 3A Dairy	UX1SP Clipper®, #7 Alligator®, #62 Staple
VOLTA FMW-3 HOMOGENEOUS CREAM TPE SMOOTH X SMOOTH								
2011	20102011	-20°F to 140°F	10.1	3 mm	0.060	1.625"	FDA, USDA, EU, 3A Dairy	UX1SP Clipper®, #15 Alligator®, #125 Staple
VOLTA FMW-4 HOMOGENEOUS CREAM TPE SMOOTH X SMOOTH								
2012	20102012	-20°F to 140°F	13.5	4 mm	0.080	2.375"	FDA, USDA, EU, 3A Dairy	U2 Clipper®, #25 Alligator®, #187 Staple
VOLTA FMW-5 HOMOGENEOUS CREAM TPE SMOOTH X SMOOTH								
2013	20102013	-20°F to 140°F	16.9	5 mm	0.100	3.125"	FDA, USDA, EU, 3A Dairy	U4 Clipper®, #25 Alligator®, #187 Staple

High-tech custom blend of polymers provides cut resistance and flexibility. These belts are truly homogeneous, with no plies to separate or carcass yarns to fray. A standard in the meat and poultry industry, and in several baking applications.

**VOLTA
ABBREVIATION
KEY**

- B** = Blue
- CEB-B** = Cover Embossed Bottom
- CT** = Crescent Top
- DD** = DualDrive
- DDSP** = DualDrive Small Pulley
- E** = Embossed
- F** = Flat
- G** = Gray
- H** = Hard Durometer (Polyester Compound)
- ITO-50** = Impression Top
- IRT** = Rooftop
- L** = Light Durometer (TPE Compound)
- M** = Medium Durometer (TPE Compound)
- MC** = Meat-Cleat
- R** = Reinforced
- SD** = SuperDrive™
- SP** = Spike Top
- TPE** = Thermoplastic Elastomers
- W** = White/Cream
- Z** = Dark Green



SPEC#	PART#	TEMP.	PULL FORCE PRETENSION 1%	THICKNESS	WEIGHT (PIW)	MIN. PULLEY	ACCEPTED	RECOMMENDED LACING
VOLTA FHB-2 HOMOGENEOUS BLUE POLYESTER SMOOTH X SMOOTH								
2008	20102008	-5°F to 140°F	11.2	2 mm	0.040	1.1875"	FDA, USDA, EU, 3A Dairy	UX1SP Clipper®, #1 Alligator®, #62 Staple
VOLTA FHB-3 HOMOGENEOUS BLUE POLYESTER SMOOTH X SMOOTH								
2017	20102017	-5°F to 140°F	16.8	3 mm	0.060	3.5"	FDA, USDA, EU, 3A Dairy	UX1SP Clipper®, #15 Alligator®, #125 Staple
VOLTA FMB-2 HOMOGENEOUS BLUE TPE SMOOTH X SMOOTH								
2014	20102014	-20°F to 140°F	6.8	2 mm	0.040	1.1875"	FDA, USDA, EU, 3A Dairy	UX1SP Clipper®, #1 Alligator®, #62 Staple
VOLTA FMB-3 HOMOGENEOUS BLUE TPE SMOOTH X SMOOTH								
2015	20102015	-20°F to 140°F	10.1	3 mm	0.060	1.875"	FDA, USDA, EU, 3A Dairy	UX1SP Clipper®, #15 Alligator®, #125 Staple
VOLTA FMB-4 HOMOGENEOUS BLUE TPE SMOOTH X SMOOTH								
2018	20102018	-20°F to 140°F	13.5	4 mm	0.080	2.375"	FDA, USDA, EU, 3A Dairy	U2 Clipper®, #25 Alligator®, #187 Staple
VOLTA FMB-5 HOMOGENEOUS BLUE TPE SMOOTH X SMOOTH								
2019	20102019	-20°F to 140°F	16.9	5 mm	0.100	3.125"	FDA, USDA, EU, 3A Dairy	U4 Clipper®, #25 Alligator®, #187 Staple

High-tech custom blend of polymers provides cut resistance and flexibility. These belts are truly homogeneous, with no plies to separate or carcass yarns to fray. A standard in the meat and poultry industry, and in several baking applications.

SPEC#	PART#	TEMP.	PULL FORCE PRETENSION 1%	THICKNESS	WEIGHT (PIW)	MIN. PULLEY	ACCEPTED	RECOMMENDED LACING
VOLTA FELB-2 HOMOGENEOUS BLUE TPE SMOOTH X EMBOSSED								
2026	20102026	-40°F to 120°F	2.24	2 mm	0.040	0.5"	FDA, EU	UX1SP Clipper®, #1 Alligator®, #62 Staple
VOLTA FEMB-2 HOMOGENEOUS BLUE TPE SMOOTH X EMBOSSED								
2036	20102036	-20°F to 140°F	4.5	2 mm	0.040	1.1875"	FDA, USDA, EU, 3A Dairy	UX1SP Clipper®, #1 Alligator®, #62 Staple

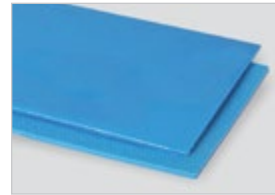

High-tech custom blend of polymers provides cut resistance and flexibility. The embossed bottom offers a lower coefficient of friction for slider beds. These belts are truly homogeneous, with no plies to separate or carcass yarns to fray. A standard in the meat and poultry industry, and in several baking applications.

SPEC#	PART#	TEMP.	PULL FORCE PRETENSION 1%	THICKNESS	WEIGHT (PIW)	MIN. PULLEY	ACCEPTED	RECOMMENDED LACING
VOLTA FRMW-2.5 HOMOGENEOUS CREAM TPE SMOOTH X FABRIC BACK								
2061	20102061	-20°F to 140°F	36.2	2.5 mm	0.053	1.1875"	FDA, USDA, EU, 3A Dairy	UX1SP Clipper®, #7 Alligator®, #62 Staple
VOLTA FRMW-3 HOMOGENEOUS CREAM TPE SMOOTH X FABRIC BACK								
2062	20102062	-20°F to 140°F	39	3 mm	0.063	1.375"	FDA, USDA, EU, 3A Dairy	UX1SP Clipper®, #15 Alligator®, #125 Staple



High-tech custom blend of polymers provides cut resistance and flexibility. The reinforced fabric provides a high strength rating. A standard in the meat and poultry industry, and in several baking applications.

SPEC#	PART#	TEMP.	PULL FORCE PRETENSION 1%	THICKNESS	WEIGHT (PIW)	MIN. PULLEY	ACCEPTED	RECOMMENDED LACING
VOLTA FEMW-2.5 ITO-50 HOMOGENEOUS CREAM TPE IMPRESSION X EMBOSSED								
2033	20102033	-20°F to 140°F	4.2	2.5 mm	0.044	1.375"	FDA, USDA, EU, 3A Dairy	UX1SP Clipper®, #7 Alligator®, #62 Staple
VOLTA FELW-3 ITO-50 HOMOGENEOUS CREAM TPE IMPRESSION X EMBOSSED								
2038	20102038	-40°F to 120°F	2.8	3 mm	0.050	0.6875"	FDA, EU	UX1SP Clipper®, #15 Alligator®, #125 Staple
VOLTA FRMW-2.5 ITO-50 HOMOGENEOUS CREAM TPE IMPRESSION X FABRIC BACK								
2090	20102090	-20°F to 140°F	25.2	2.5 mm	0.044	1.4375"	FDA, EU	UX1SP Clipper®, #7 Alligator®, #62 Staple



High-tech custom blend of polymers provides cut resistance and flexibility. These belts are truly homogeneous, with no plies to separate or carcass yarns to fray. This belt offers an ITO-50 profile (pebbletop) for small inclines. A standard in the meat and poultry industry, and in several baking applications.

SPEC#	PART#	TEMP.	PULL FORCE PRETENSION 1%	THICKNESS	WEIGHT (PIW)	MIN. PULLEY	ACCEPTED	RECOMMENDED LACING
VOLTA FEMB-3 CT HOMOGENEOUS BLUE TPE CRESCENT X EMBOSSED								
2039	20102039	-20°F to 140°F	6.75	3 mm	0.070	2.375"	FDA, USDA, EU, 3A Dairy	UX1SP Clipper®, #15 Alligator®, #125 Staple
VOLTA FMB-3 CT HOMOGENEOUS BLUE TPE CRESCENT X SMOOTH								
2040	20102040	-20°F to 140°F	10.12	3 mm	0.070	2.375"	FDA, USDA, EU, 3A Dairy	UX1 Clipper®, #15 Alligator®, #125 Staple



High-tech custom blend of polymers provides cut resistance and flexibility. These belts are truly homogeneous, with no plies to separate or carcass yarns to fray. A standard in the meat and poultry industry, and in several baking applications.

VOLTA ABBREVIATION KEY

- B** = Blue
- CEB-B** = Cover Embossed Bottom
- CT** = Crescent Top
- DD** = DualDrive
- DDSP** = DualDrive Small Pulley
- E** = Embossed
- F** = Flat
- G** = Gray
- H** = Hard Durometer (Polyester Compound)
- ITO-50** = Impression Top
- IRT** = Rooftop
- L** = Light Durometer (TPE Compound)
- M** = Medium Durometer (TPE Compound)
- MC** = Meat-Cleat
- R** = Reinforced
- SD** = SuperDrive™
- SP** = Spike Top
- TPE** = Thermoplastic Elastomers
- W** = White/Cream
- Z** = Dark Green

**VOLTA
ABBREVIATION
KEY**

B = Blue

CEB-B = Cover
Embossed Bottom

CT = Crescent Top

DD = DualDrive

DDSP = DualDrive
Small Pulley

E = Embossed

F = Flat

G = Gray

H = Hard
Durometer
(Polyester
Compound)

ITO-50 =
Impression Top

IRT = Rooftop

L = Light
Durometer
(TPE Compound)

M = Medium
Durometer
(TPE Compound)

MC = Meat-Cleat

R = Reinforced

SD =
SuperDrive™

SP = Spike Top

TPE =
Thermoplastic
Elastomers

W = White/Cream

Z = Dark Green

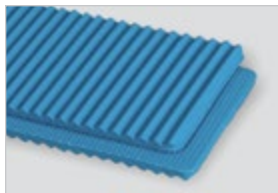

SPEC#	PART#	TEMP.	PULL FORCE PRETENSION 1%	THICKNESS	WEIGHT (PIW)	MIN. PULLEY	ACCEPTED	RECOMMENDED LACING
VOLTA FEMB-4 IRT HOMOGENEOUS BLUE TPE ROOFTOP X EMBOSSED								
2034	20102034	-20°F to 140°F	6.8	4 mm	0.073	2.1875"	FDA, USDA, EU, 3A Dairy	UX1SP Clipper®, #25 Alligator®, #187 Staple
VOLTA FEMB-3.5 IRT HOMOGENEOUS BLUE TPE ROOFTOP X EMBOSSED								
2035	20102035	-20°F to 140°F	5.6	3.5 mm	0.060	1.875"	FDA, USDA, EU, 3A Dairy	U2 Clipper®, #25 Alligator®, #125 Staple

High-tech custom blend of polymers provides characteristics such as high strength, cut resistance and flexibility. These belts are truly homogeneous, with no plies to separate or carcass yarns to fray. The IRT profile allows the product to be raised from the base of the belt. A standard in the meat and poultry industry, and in several baking applications.



SPEC#	PART#	TEMP.	PULL FORCE PRETENSION 1%	THICKNESS	WEIGHT (PIW)	MIN. PULLEY	ACCEPTED	RECOMMENDED LACING
VOLTA FEMB-3 SP HOMOGENEOUS BLUE TPE SPIKE X EMBOSSED								
2024	20102024	-20°F to 140°F	6.8	3 mm	0.062	2"	FDA, USDA, EU, 3A Dairy	UX1SP Clipper®, #15 Alligator®, #125 Staple
VOLTA FELB-3 SP HOMOGENEOUS BLUE TPE SPIKE X EMBOSSED								
2025	20102025	-40°F to 120°F	3.36	3 mm	0.062	1.125"	FDA, EU	UX1SP Clipper®, #15 Alligator®, #125 Staple

High-tech custom blend of polymers provides cut resistance and flexibility. These belts are truly homogeneous, with no plies to separate or carcass yarns to fray. A standard in the meat and poultry industry.

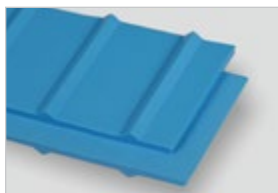

SPEC#	PART#	TEMP.	PULL FORCE PRETENSION 1%	THICKNESS	WEIGHT (PIW)	MIN. PULLEY	ACCEPTED	RECOMMENDED LACING
VOLTA FELB-2.5 MC HOMOGENEOUS BLUE TPE MEAT-CLEAT X EMBOSSED								
2027	20102027	-40°F to 120°F	2.8	2.5 mm	0.070	1.875"	FDA, EU	UX1SP Clipper®, #7 Alligator®, #62 Staple
VOLTA FEMB-3 MC HOMOGENEOUS BLUE TPE MEAT-CLEAT X EMBOSSED								
2037	20102037	-20°F to 140°F	6.8	3 mm	0.070	2.75"	FDA, USDA, EU, 3A Dairy	UX1 Clipper®, #15 Alligator®, #125 Staple

High-tech custom blend of polymers provides characteristics such as high strength, cut resistance and flexibility. These belts are truly homogeneous, with no plies to separate or carcass yarns to fray. The meat-cleat profile can be used on slight inclines and to keep product raised off the base of the belt. A standard in the meat and poultry industry, and in several baking applications.



SPEC#	PART#	TEMP.	PULL FORCE PRETENSION 1%	THICKNESS	WEIGHT (PIW)	MIN. PULLEY	ACCEPTED	RECOMMENDED LACING
VOLTA FRLB-2 CEB-B HOMOGENEOUS BLUE TPE SMOOTH X COVERED								
2032	20102032	-40°F to 120°F	12.4	2 mm	0.045	0.75"	FDA, EU	UX1SP Clipper®, #1 Alligator®, #62 Staple
VOLTA FRMB-3 CEB-B HOMOGENEOUS BLUE TPE SMOOTH X COVERED								
2041	20102041	-20°F to 140°F	38	3 mm	0.062	1.875"	FDA, USDA, EU, 3A Dairy	UX1SP Clipper®, #15 Alligator®, #125 Staple

High-tech custom blend of polymers provides characteristics such as higher strength due to the reinforced fabric, cut resistance and flexibility. This belt also features a urethane skin covered bottom. A standard in the meat and poultry industry, and in several baking applications.

VOLTA POSITIVE DRIVE

VOLTA POSITIVE DRIVE BELTS

Volta positive drive belts are manufactured with materials resistant to cuts and abrasion, thus eliminating places where bacteria can harbor and grow. This makes for easy and efficient cleaning, meaning you save on labor costs and production downtime.

POSITIVE DRIVE BELT FEATURES INCLUDE:

- ▶ Extruded integral teeth prevent slippage of belt
- ▶ High flexibility extends operating life
- ▶ Smooth homogeneous surface for low bacteria counts, longer shelf life and odor resistance
- ▶ Non-sticking smooth or impression top for easy product release
- ▶ Resistant to water, oil and chemicals unlike PVC and polyurethane belts
- ▶ No fabrics or modular components
- ▶ Minimal pretension of belt is required
- ▶ Reduced water usage, detergent and sewage consumption for lower sanitation costs
- ▶ Less cleaning time increases production time

POSITIVE DRIVE BELTS ARE AVAILABLE IN THE FOLLOWING TYPES:



DUALDRIVE

- ▶ Replaces modular belts with minimal retrofit
- ▶ No seams, belt extruded in 100' straight lengths
- ▶ May be used as cleats when teeth face up

DUALDRIVE SP (SMALL PULLEY)

- ▶ Provides tight transfer of product between conveyors
- ▶ Requires lighter conveyor construction

SUPERDRIVE™

- ▶ Utilized primarily on newer OEM equipment
- ▶ One solid lug in center of the conveyor

SPEC#	PART#	TEMP.	THICKNESS	WEIGHT (PIW)	MIN. PULLEY	ACCEPTED	RECOMMENDED LACING
VOLTA FMB-2.5 DDSP HOMOGENEOUS BLUE TPE SMOOTH X DUALDRIVE SP							
2050	20102050	-20°F to 140°F	2.5 mm	0.074	2"	FDA, USDA, EU, 3A Dairy	UX1SP Clipper®, #7 Alligator®, #62 Staple



These positive drive belts are replacing many plastic modular belts because their construction is more resistant to bacteria. This high-tech custom blend of polymers provides characteristics such as cut resistance and flexibility. These belts are truly homogeneous, with no plies to separate or carcass yarns to fray. A standard in the meat and poultry industry, and in several baking applications.

SPEC#	PART#	TEMP.	THICKNESS	WEIGHT (PIW)	MIN. PULLEY	ACCEPTED	RECOMMENDED LACING
VOLTA FMB-3 DD HOMOGENEOUS BLUE TPE SMOOTH X DUALDRIVE							
2060	20102060	-5°F to 140°F	3 mm	0.075	3.25"	FDA, USDA, EU, 3A Dairy	UX1SP Clipper®, #15 Alligator®, #125 Staple



These positive drive belts are replacing many plastic modular belts because their construction is more resistant to bacteria. This high-tech custom blend of polymers provides characteristics such as cut resistance and flexibility. These belts are truly homogeneous, with no plies to separate or carcass yarns to fray. A standard in the meat and poultry industry, and in several baking applications.

VOLTA ABBREVIATION KEY

- B** = Blue
- CEB-B** = Cover Embossed Bottom
- CT** = Crescent Top
- DD** = DualDrive
- DDSP** = DualDrive Small Pulley
- E** = Embossed
- F** = Flat
- G** = Gray
- H** = Hard Durometer (Polyester Compound)
- ITO-50** = Impression Top
- IRT** = Rooftop
- L** = Light Durometer (TPE Compound)
- M** = Medium Durometer (TPE Compound)
- MC** = Meat-Cleat
- R** = Reinforced
- SD** = SuperDrive™
- SP** = Spike Top
- TPE** = Thermoplastic Elastomers
- W** = White/Cream
- Z** = Dark Green

**VOLTA
ABBREVIATION
KEY**

- B** = Blue
- CEB-B** = Cover Embossed Bottom
- CT** = Crescent Top
- DD** = DualDrive
- DDSP** = DualDrive Small Pulley
- E** = Embossed
- F** = Flat
- G** = Gray
- H** = Hard Durometer (Polyester Compound)
- ITO-50** = Impression Top
- IRT** = Rooftop
- L** = Light Durometer (TPE Compound)
- M** = Medium Durometer (TPE Compound)
- MC** = Meat-Cleat
- R** = Reinforced
- SD** = SuperDrive™
- SP** = Spike Top
- TPE** = Thermoplastic Elastomers
- W** = White/Cream
- Z** = Dark Green



SPEC#	PART#	TEMP.	THICKNESS	WEIGHT (PIW)	MIN. PULLEY	ACCEPTED	RECOMMENDED LACING
VOLTA FMW-3 DD HOMOGENEOUS CREAM TPE SMOOTH X DUALDRIVE							
2056	20102056	-5°F to 140°F	3 mm	0.075	3.25"	FDA, USDA, EU, 3A Dairy	UX1SP Clipper®, #15 Alligator®, #125 Staple

These positive drive belts are replacing many plastic modular belts because their construction is more resistant to bacteria. This high-tech custom blend of polymers provides characteristics such as cut resistance and flexibility. These belts are truly homogeneous, with no plies to separate or carcass yarns to fray. A standard in the meat and poultry industry, and in several baking applications.

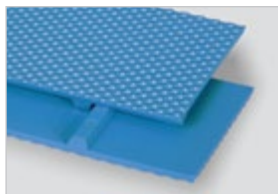

SPEC#	PART#	TEMP.	THICKNESS	WEIGHT (PIW)	MIN. PULLEY	ACCEPTED	RECOMMENDED LACING
VOLTA FMB-3 DD ITO-50 HOMOGENEOUS BLUE TPE IMPRESSION X DUALDRIVE							
2064	20102064	-5°F to 140°F	3 mm	0.075	3.25"	FDA, USDA, EU, 3A Dairy	UX1SP Clipper®, #15 Alligator®, #125 Staple

These positive drive belts are replacing many plastic modular belts because their construction is more resistant to bacteria. This high-tech custom blend of polymers provides characteristics such as cut resistance and flexibility. These belts are truly homogeneous, with no plies to separate or carcass yarns to fray. A standard in the meat and poultry industry, and in several baking applications.

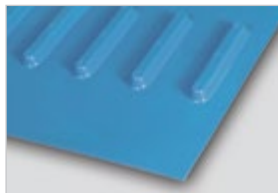

SPEC#	PART#	TEMP.	THICKNESS	WEIGHT (PIW)	MIN. PULLEY	ACCEPTED	RECOMMENDED LACING
VOLTA FMB-3 SD HOMOGENEOUS BLUE TPE SMOOTH X SUPERDRIVE™							
2080	20102080	-5°F to 140°F	3 mm	0.065	3.25"	NSF, FDA, USDA, EU, 3A Dairy	UX1SP Clipper®, #15 Alligator®, #125 Staple
VOLTA FMB-4 SD HOMOGENEOUS BLUE TPE SMOOTH X SUPERDRIVE™							
2081	20102081	-5°F to 140°F	4 mm	0.085	4.75"	NSF, FDA, USDA, EU, 3A Dairy	U2 Clipper®, #25 Alligator®, #187 Staple
VOLTA FHB-3 SD HOMOGENEOUS BLUE POLYESTER SMOOTH X SUPERDRIVE™							
2086	20102086	-5°F to 140°F	3 mm	0.065	4"	NSF, FDA, USDA, EU, 3A Dairy	UX1SP Clipper®, #15 Alligator®, #125 Staple
VOLTA FHB-4 SD HOMOGENEOUS BLUE POLYESTER SMOOTH X SUPERDRIVE™							
2087	20102087	-5°F to 140°F	4 mm	0.085	5.5"	NSF, FDA, USDA, EU, 3A Dairy	U2 Clipper®, #25 Alligator®, #187 Staple

These positive drive belts are replacing many plastic modular belts because their construction is more resistant to bacteria. This high-tech custom blend of polymers provides characteristics such as cut resistance and flexibility. These belts are truly homogeneous, with no plies to separate or carcass yarns to fray. A standard in the meat and poultry industry, and in several baking applications.



SPEC#	PART#	TEMP.	THICKNESS	WEIGHT (PIW)	MIN. PULLEY	ACCEPTED	RECOMMENDED LACING
VOLTA FMW-3 SD HOMOGENEOUS CREAM TPE SMOOTH X SUPERDRIVE™							
2082	20102082	-5°F to 140°F	3 mm	0.065	3.25"	NSF, FDA, USDA, EU, 3A Dairy	UX1SP Clipper®, #15 Alligator®, #125 Staple
VOLTA FMW-4 SD HOMOGENEOUS CREAM TPE SMOOTH X SUPERDRIVE™							
2083	20102083	-5°F to 140°F	4 mm	0.085	4.75"	NSF, FDA, USDA, EU, 3A Dairy	U2 Clipper®, #25 Alligator®, #187 Staple
VOLTA FHW-3 SD HOMOGENEOUS CREAM POLYESTER SMOOTH X SUPERDRIVE™							
2088	20102088	-5°F to 140°F	3 mm	0.065	4"	NSF, FDA, USDA, EU, 3A Dairy	UX1SP Clipper®, #15 Alligator®, #125 Staple
VOLTA FHW-4 SD HOMOGENEOUS CREAM POLYESTER SMOOTH X SUPERDRIVE™							
2089	20102089	-5°F to 140°F	4 mm	0.085	5.5"	NSF, FDA, USDA, EU,	U2 Clipper®, #25 Alligator®,

VOLTA GENERAL CONVEYING

VOLTA ABBREVIATION KEY

- B** = Blue
- CEB-B** = Cover Embossed Bottom
- CT** = Crescent Top
- DD** = DualDrive
- DDSP** = DualDrive Small Pulley
- E** = Embossed
- F** = Flat
- G** = Gray
- H** = Hard Durometer (Polyester Compound)
- ITO-50** = Impression Top
- IRT** = Rooftop
- L** = Light Durometer (TPE Compound)
- M** = Medium Durometer (TPE Compound)
- MC** = Meat-Cleat
- R** = Reinforced
- SD** = SuperDrive™
- SP** = Spike Top
- TPE** = Thermoplastic Elastomers
- W** = White/Cream
- Z** = Dark Green

VOLTA GENERAL CONVEYING BELTS

From soft belts with high grip, to hard surfaces that resist cutting, punctures and abrasion, we have the Volta belt for your special application.

Volta's general conveying belts offer the same unique homogenous characteristics as the food-grade belting. This product line offers a wide range of belts designed to meet some of the most demanding requirements and challenging applications in the field.

- ▶ Do not absorb industrial oils, fluids, or chemicals
- ▶ Low coefficient of friction for slider bed applications
- ▶ Harder durometer covers are available for more abrasion resistance
- ▶ Excellent impact absorption from falling/dropping products
- ▶ Highly resistant to cuts and impact punctures
- ▶ Easily welded while on the conveyor, reducing production downtime

THESE BELTS ARE MOST SUITABLE FOR CONVEYING CERAMICS, GLASS, CARDBOARD, METAL PARTS, RECYCLING, AND MANY OTHERS, AND ARE COMMONLY USED IN THESE APPLICATIONS:

- ▶ Construction Industries
- ▶ Detergents and Chemicals
- ▶ Metal Industries
- ▶ Recycling Industry
- ▶ Packaging Industry
- ▶ Plastic Industry
- ▶ Printing Industry
- ▶ Fabric Industry
- ▶ Glass Industry
- ▶ Shingle Lines
- ▶ Concrete Block Facilities

SPEC#	PART#	TEMP.	PULL FORCE PRETENSION 1%	THICKNESS	WEIGHT (PIW)	MIN. PULLEY	RECOMMENDED LACING
VOLTA FRG-2 HOMOGENEOUS GRAY TPE SMOOTH X FABRIC BACK							
2022	20102022	-20°F to 140°F	33.5	2 mm	0.046	1.0625"	UX1SP Clipper®, #1 Alligator®, #62 Staple
VOLTA FRG-3 HOMOGENEOUS GRAY TPE SMOOTH X FABRIC BACK							
2023	20102023	-20°F to 140°F	39	3 mm	0.063	1.375"	UX1SP Clipper®, #7 Alligator®, #125 Staple

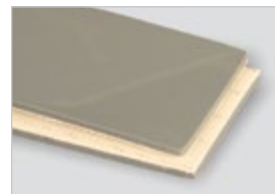

High-tech custom blend of polymers provides characteristics such as higher strength due to the reinforced fabric, cut resistance and flexibility. These belts are ideal for high-abrasion industrial service applications.

SPEC#	PART#	TEMP.	PULL FORCE PRETENSION 1%	THICKNESS	WEIGHT (PIW)	MIN. PULLEY	RECOMMENDED LACING
VOLTA FEZ-2 HOMOGENEOUS GREEN TPE SMOOTH X EMBOSSED							
2105	20102105	-20°F to 140°F	4.5	2 mm	0.042	1.1875"	UX1SP Clipper®, #1 Alligator®, #62 Staple
VOLTA FEZ-2.5 HOMOGENEOUS GREEN TPE SMOOTH X EMBOSSED							
2106	20102106	-20°F to 140°F	5.6	2.5 mm	0.051	1.375"	UX1SP Clipper®, #7 Alligator®, #62 Staple
VOLTA FEZ-3.2 HOMOGENEOUS GREEN TPE SMOOTH X EMBOSSED							
2107	20102107	-20°F to 140°F	7.3	3.2 mm	0.067	1.75"	UX1SP Clipper®, #25 Alligator®, #125 Staple
VOLTA FEZ-4 HOMOGENEOUS GREEN TPE SMOOTH X EMBOSSED							
2108	20102108	-20°F to 140°F	9	4 mm	0.083	2.375"	U2 Clipper®, #25 Alligator®, #187 Staple

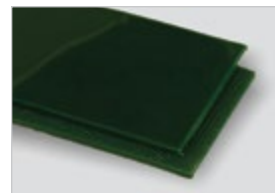

High-tech custom blend of polymers provides characteristics such as high strength, cut resistance and flexibility. These belts are truly homogeneous, with no plies to separate or carcass yarns to fray. These belts are ideal for high-abrasion industrial service applications.

VOLTA
ABBREVIATION
KEY

- F = Flat
- G = Gray
- R = Reinforced
- Z = Dark Green

PACKAGE
HANDLING

DESCRIPTION
ABBREVIATION
KEY

- PVC = Poly Vinyl
Chloride

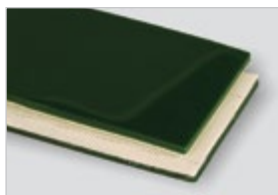

SPEC#	PART#	TEMP.	PULL FORCE PRETENSION 1%	THICKNESS	WEIGHT (PIW)	MIN. PULLEY	RECOMMENDED LACING
VOLTA FRGZ-3 HOMOGENEOUS GREEN TPE SMOOTH X FABRIC BACK							
2113	20102113	-20°F to 140°F	39	3 mm	0.0625	3.125"	UX1SP Clipper®, #15 Alligator®, #125 Staple

High-tech custom blend of polymers provides characteristics such as higher strength due to the reinforced fabric carcass, cut resistance and flexibility. These belts are ideal for high-abrasion industrial service applications.



SPEC#	PART#	TEMP.	THICKNESS	WEIGHT (PIW)	MIN. PULLEY	RECOMMENDED LACING
2-PLY 100# SPUN POLYESTER GREEN RMV MATTE COVER X MATTE COVER						
3808	20103808	-20°F to 180°F	0.109"	0.050	2"	UX1 Clipper®, #7 Alligator®, #125 Staple

Popular and versatile belt when top and bottom covers are needed. Matte-finished covers offer excellent gripping capabilities. With the negative temperature range, this belt can be used in freezer applications. Operates on small pulleys and tracks well.



SPEC#	PART#	TEMP.	THICKNESS	WEIGHT (PIW)	MIN. PULLEY	RECOMMENDED LACING
3-PLY 42# COTTON/POLYESTER BROWN NITRILE FRICTION X FRICTION						
4101	20104101	20°F to 212°F	0.063"	0.037	1.5"	UX1SP Clipper®, #7 Alligator®, #62 Staple
5-PLY 70# COTTON/POLYESTER BROWN NITRILE FRICTION X FRICTION						
4103	20104103	20°F to 212°F	0.109"	0.064	2.5"	UX1 Clipper®, #7 Alligator®, #62 Staple
7-PLY 100# COTTON/POLYESTER BROWN NITRILE FRICTION X FRICTION						
4104	20104104	20°F to 212°F	0.14"	0.091	3.5"	U2 Clipper®, #15 Alligator®, #125 Staple

A tightly woven blend of cotton and polyester fabric. Often referred to as a "sheeting belt" for a variety of light-and medium-weight conveying. Nitrile compounds make this construction popular for oily conditions, particularly metal parts, and for carrying tapes for folding machines. It is oil-grease-and chemical-resistant.



SPEC#	PART#	TEMP.	THICKNESS	WEIGHT (PIW)	MIN. PULLEY	RECOMMENDED LACING
3-PLY 150# SPUN POLYESTER TAN PVC FRICTION X BRUSHED						
4106	20104106	0°F to 180°F	0.109"	0.070	3"	UX1 Clipper®, #7 Alligator®, #125 Staple

PVC built in the traditional design of rubber transmission belting. Constructed of spun polyester, this product provides great tracking, strength, and excellent lace holding ability. Thermoplastic cover allows for the full range of fabrications including smooth endless finger splicing. Light oil resistance and low coefficient of friction makes this a fast and easy replacement for the more expensive rubber transmission belts.



SPEC#	PART#	TEMP.	THICKNESS	WEIGHT (PIW)	MIN. PULLEY	RECOMMENDED LACING
3-PLY 150# SPUN POLYESTER BLACK PVC FRICTION X BRUSHED						
4108	20104108	0°F to 180°F	0.109"	0.070	3"	UX1 Clipper®, #7 Alligator®, #125 Staple

PVC built in the traditional design of rubber transmission belting. Constructed of spun polyester, this product provides great tracking, strength, and excellent lace holding ability. Thermoplastic cover allows for the full range of fabrications including smooth endless finger splicing. Good oil resistance and low coefficient of friction makes this a fast and easy replacement for the more expensive rubber transmission belts.

DESCRIPTION
ABBREVIATION
KEY

PVC = Poly Vinyl Chloride

SBR = Styrene Butadiene Rubber

SBR has excellent abrasion resistance and low temperature properties.

SPEC#	PART#	TEMP.	THICKNESS	WEIGHT (PIW)	MIN. PULLEY	RECOMMENDED LACING
4-PLY 200# SPUN POLYESTER BLACK PVC FRICTION X BRUSHED						
4109	20104109	0°F to 180°F	0.16"	0.080	4"	U2 Clipper®, #15 Alligator®, #187 Staple

PVC built in the traditional design of rubber transmission belting. Constructed of spun polyester, this product provides great tracking, strength, and excellent lace holding ability. Thermoplastic cover allows for the full range of fabrications including smooth endless finger splicing. Moderate oil resistance and low coefficient of friction makes this a fast and easy replacement for the more expensive rubber transmission belts.

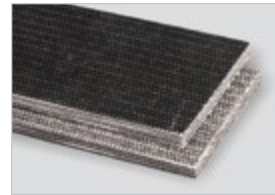

SPEC#	PART#	TEMP.	THICKNESS	WEIGHT (PIW)	MIN. PULLEY	RECOMMENDED LACING
3-PLY 90# COTTON/POLYESTER TAN SBR TRANSMISSION FRICTION X FRICTION						
4110	20104110	0°F to 250°F	0.14"	0.063	3"	UX1 Clipper®, #7 Alligator®, #125 Staple
4-PLY 140# COTTON/POLYESTER TAN SBR TRANSMISSION FRICTION X FRICTION						
4111	20104111	0°F to 250°F	0.172"	0.085	3"	U2 Clipper®, #20 Alligator®, #187 Staple

Polyester/cotton belt construction which moves superior flexing feature. Non-marking tan product is a versatile and economical choice for package handling, production/assembly lines and parcels.



SPEC#	PART#	TEMP.	THICKNESS	WEIGHT (PIW)	MIN. PULLEY	RECOMMENDED LACING
4-PLY 200# POLYESTER/NYLON BLACK NITRILE 3/32 COVER X BARE						
4112	20104112	0°F to 250°F	0.25"	0.131	4"	#5 Clipper®, #25 Alligator®, #187 Staple

Strong and durable polyester/nylon carcass, which offers small pulley diameters. Oil-resistant and high-strength carcass make this belt an excellent choice for wood, metal sanding and finishing operations.



SPEC#	PART#	TEMP.	THICKNESS	WEIGHT (PIW)	MIN. PULLEY	RECOMMENDED LACING
3-PLY 150# POLYESTER/NYLON BLACK NITRILE COVER X FRICTION						
4131	20104131	0°F to 250°F	0.14"	0.077	2"	UX1 Clipper®, #7 Alligator®, #125 Staple

Versatile belt with oil-grease-and fat-resistant covers. Popular for conveying a variety of products such as food stuffs and metal parts. Belt is FDA approved.



SPEC#	PART#	TEMP.	THICKNESS	WEIGHT (PIW)	MIN. PULLEY	RECOMMENDED LACING
NEEDED 120# POLYESTER BLACK PVC FRICTION X BRUSHED						
4136	20104136	0°F to 180°F	0.135"	0.010	4"	UX1 Clipper®, #7 Alligator®, #125 Staple

A favorite in the package handling industry. This belt resists stringing and provides extremely quiet service.

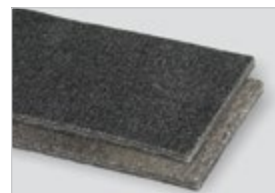

SPEC#	PART#	TEMP.	THICKNESS	WEIGHT (PIW)	MIN. PULLEY	RECOMMENDED LACING
4-PLY 200# POLYESTER BLACK NITRILE FRICTION X FRICTION						
4113	20104113	20°F to 212°F	0.14"	0.068	4"	U2 Clipper®, #15 Alligator®, #187 Staple

Heavy-duty transmission style construction with a nitrile impregnation on both sides. Superior strength, oil

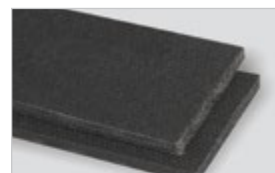

DESCRIPTION
ABBREVIATION
KEY

PVC = Poly Vinyl
Chloride

SBR = Styrene
Butadiene Rubber



SPEC#	PART#	TEMP.	THICKNESS	WEIGHT (PIW)	MIN. PULLEY	RECOMMENDED LACING
3-PLY 105 # COTTON/POLYESTER BLACK SBR TRANSMISSION FRICTION X FRICTION						
4115	20104115	0°F to 250°F	0.125"	0.063	2.5"	UX1 Clipper®, #7 Alligator®, #125 Staple
4-PLY 140# COTTON/POLYESTER BLACK SBR TRANSMISSION FRICTION X FRICTION						
4116	20104116	0°F to 250°F	0.14"	0.080	4"	U2 Clipper®, #20 Alligator®, #187 Staple

This belt has long been the standard for a wide variety of conveyor applications including both slider/roller bed service. Popular for unit, package and parcel handling. Has four plies for higher tension requirements and added durability.



SPEC#	PART#	TEMP.	THICKNESS	WEIGHT (PIW)	MIN. PULLEY	RECOMMENDED LACING
3-PLY 105# COTTON/POLYESTER HOT STOCK AND WATER COTTON X FRICTION						
4117	20104117	0°F to 250°F	0.125"	0.066	2.5"	UX1 Clipper®, #15 Alligator®, #125 Staple
4-PLY 140# COTTON/POLYESTER HOT STOCK AND WATER COTTON X FRICTION						
4118	20104118	0°F to 250°F	0.171"	0.088	3"	U2 Clipper®, #15 Alligator®, #187 Staple

With the bare surface down it is a premium product that provides extremely low coefficient of friction. Bare side up provides service as an accumulation and/or deflector belt. Named for its use in conveying uncured rubber in tire manufacturing. This product also has many package handling uses. Hot stock and water belt.



SPEC#	PART#	TEMP.	THICKNESS	WEIGHT (PIW)	MIN. PULLEY	RECOMMENDED LACING
3-PLY 105# COTTON/POLYESTER WHITE SBR HOT STOCK AND WATER SILICONE COVER X FRICTION						
4119	20104119	0°F to 250°F	0.156"	0.077	3"	U2 Clipper®, #15 Alligator®, #187 Staple

A premium product used where high temperatures and excellent release properties are required. Hot stock and water belt.

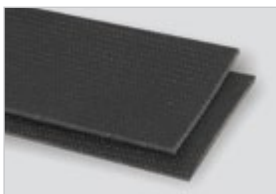

SPEC#	PART#	TEMP.	THICKNESS	WEIGHT (PIW)	MIN. PULLEY	RECOMMENDED LACING
2-PLY 100# POLYESTER MONOFILAMENT BLACK PVC BARE X BARE						
4127	20104127	0°F to 180°F	0.078"	0.030	1"	UX1SP Clipper®, #7 Alligator®, #62 Staple

Accumulation and diversion. This product is made with tough, abrasion-resistant and rigid polyester monofilament carcasses. This construction makes these products lay flat. Thermoplastic skims allow for superior, more flexible splices.



SPEC#	PART#	TEMP.	THICKNESS	WEIGHT (PIW)	MIN. PULLEY	RECOMMENDED LACING
3-PLY 100# POLYESTER MONOFILAMENT BLACK PVC BARE X BARE						
4130	20104130	0°F to 180°F	0.109"	0.060	2.5"	U2 Clipper®, #15 Alligator®, #187 Staple

Accumulation and diversion. This product is made with tough, abrasion-resistant and rigid polyester monofilament carcasses. This construction makes these products lay flat. Thermoplastic skims allow for superior, more flexible splices.

SPEC#	PART#	TEMP.	THICKNESS	WEIGHT (PIW)	MIN. PULLEY	RECOMMENDED LACING
4-PLY 90# SLIPTOP POLYESTER TAN NITRILE BARE NYLON X FRICTION						
4129	20104129	20°F to 212°F	0.125"	0.070	2"	UX1 Clipper®, #7 Alligator®, #125 Staple



This belt features a bare nylon top ply which is virtually frictionless. Ideal for stall operations or accumulating applications where the product must stop while the belt continues to move. Automatic packaging machinery with gates and diverter arms commonly use this specification.

SPEC#	PART#	TEMP.	THICKNESS	WEIGHT (PIW)	MIN. PULLEY	RECOMMENDED LACING
2-PLY 100# SPUN POLYESTER BLACK RMV COVER X FRICTION						
4142	20104142	0°F to 180°F	0.109"	0.050	2"	UX1 Clipper®, #7 Alligator®, #125 Staple
3-PLY 150# SPUN POLYESTER BLACK RMV COVER X FRICTION						
4143	20104143	0°F to 180°F	0.141"	0.080	4"	U2 Clipper®, #15 Alligator®, #125 Staple

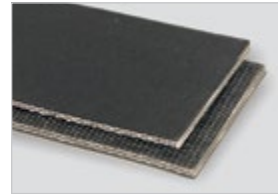

Excellent multipurpose belt which is a good alternative to nitrile covers. Spun polyester carcass provides excellent tracking and lace holding properties.

SPEC#	PART#	TEMP.	THICKNESS	WEIGHT (PIW)	MIN. PULLEY	RECOMMENDED LACING
2-PLY 100# POLYESTER BLACK PVC D-IMPRESSION COVER X BARE						
4145	20104145	0°F to 180°F	0.125"	0.070	2"	UX1 Clipper®, #7 Alligator®, #125 Staple



An excellent package handling belt with two plies of cross-rigid polyester monofilament and an aggressive dimpled top impression. Used in a wide assortment of applications where a more aggressive top cover is required, including slight inclines and declines.

SPEC#	PART#	TEMP.	THICKNESS	WEIGHT (PIW)	MIN. PULLEY	RECOMMENDED LACING
2-PLY 100# POLYESTER MONOFILAMENT BLACK RMV COVER X BARE						
4137	20104137	0°F to 180°F	0.11"	0.090	2"	UX1 Clipper®, #7 Alligator®, #125 Staple

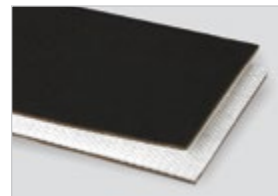

General purpose European-style polyester monofilament belts with a high-quality thermoplastic cover. Excellent choice for conveyors with small pulleys or anywhere a cross-rigid belt is required. Essentially non-marking and oil-resistant. A popular choice in many conveyor systems, including package handling and distribution centers.

SPEC#	PART#	TEMP.	THICKNESS	WEIGHT (PIW)	MIN. PULLEY	RECOMMENDED LACING
3-PLY 150# POLYESTER MONOFILAMENT BLACK RMV COVER X BARE						
4173	20104173	0°F to 180°F	0.175"	0.083	3"	U2 Clipper®, #15 Alligator®, #187 Staple



General purpose European-style polyester monofilament belt with a high-quality thermoplastic cover. Excellent choice for conveyors with small pulleys or anywhere a cross-rigid belt is required. Essentially non-marking and oil-resistant. A popular choice in many conveyor systems, including package handling and distribution centers.

SPEC#	PART#	TEMP.	THICKNESS	WEIGHT (PIW)	MIN. PULLEY	RECOMMENDED LACING
2-PLY 60# POLYESTER MONOFILAMENT BLACK PVC MATTE COVER X BARE CHECKOUT						
4140	20104140	0°F to 180°F	0.078"	0.040	1.5"	UX1SP Clipper®, #1 Alligator®, #62 Staple



DESCRIPTION ABBREVIATION KEY

PVC = Poly Vinyl Chloride

RMV = Rubber Modified Vinyl

DESCRIPTION
ABBREVIATION
KEY

PVC = Poly Vinyl
Chloride

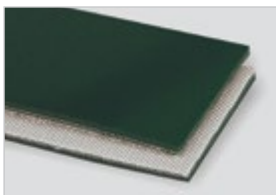

SPEC#	PART#	TEMP.	THICKNESS	WEIGHT (PIW)	MIN. PULLEY	RECOMMENDED LACING
2-PLY 100# POLYESTER MONOFILAMENT GREEN PVC HEAVY COVER X BARE						
4134	20104134	0°F to 180°F	0.156"	0.060	3.125"	U2 Clipper®, #15 Alligator®, #187 Staple
3-PLY 150# POLYESTER MONOFILAMENT GREEN PVC HEAVY COVER X BARE						
4133	20104133	0°F to 180°F	0.24"	0.119	4"	U4 Clipper®, #25 Alligator®, #187 Staple

A hard, premium PVC cover with a matte finish that reduces glare and minimizes belt marking.

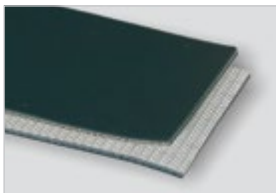

SPEC#	PART#	TEMP.	THICKNESS	WEIGHT (PIW)	MIN. PULLEY	RECOMMENDED LACING
2-PLY 100# POLYESTER MONOFILAMENT GREEN PVC COVER X BARE ANTI-STATIC						
4138	20104138	0°F to 180°F	0.3125"	0.050	4"	UX1SP Clipper®, #7 Alligator®, #62 Staple

A hard, premium PVC cover with a matte finish that reduces glare and minimizes belt marking.



SPEC#	PART#	TEMP.	THICKNESS	WEIGHT (PIW)	MIN. PULLEY	RECOMMENDED LACING
2-PLY 100# POLYESTER MONOFILAMENT GREEN URETHANE COVER X BARE						
4149	20104149	0°F to 180°F	0.052"	0.022	2"	UX1SP Clipper®, #7 Alligator®, #62 Staple

A hard, premium urethane cover for better abrasion resistance. Matte finish reduces glare and minimizes belt marking.



SPEC#	PART#	TEMP.	THICKNESS	WEIGHT (PIW)	MIN. PULLEY	RECOMMENDED LACING
2-PLY 100# POLYESTER MONOFILAMENT CLEAR PVC HARD COVER X BARE						
4153	20104153	0°F to 180°F	0.125"	0.045	2"	UX1SP Clipper®, #7 Alligator®, #62 Staple

This is a hard, premium PVC cover with characteristics of urethane. Ideal for applications where extended belt life is needed and tough top covers are used.



SPEC#	PART#	TEMP.	THICKNESS	WEIGHT (PIW)	MIN. PULLEY	RECOMMENDED LACING
2-PLY 100# POLYESTER MONOFILAMENT CLEAR URETHANE COVER X BARE ANTI-STATIC						
4152	20104152	0°F to 180°F	0.078"	0.045	1.75"	UX1SP Clipper®, #7 Alligator®, #62 Staple

A hard, premium urethane cover for better abrasion resistance. Matte finish reduces glare and minimizes belt marking. Anti-static carcass.



SPEC#	PART#	TEMP.	THICKNESS	WEIGHT (PIW)	MIN. PULLEY	RECOMMENDED LACING
2-PLY 100# POLYESTER MONOFILAMENT CLEAR URETHANE PEBBLETOP X BARE ANTI-STATIC						
4148	20104148	0°F to 180°F	0.08"	0.062	1.5"	UX1 Clipper®, #7 Alligator®, #62 Staple

A premium urethane belt that utilizes two plies of cross-rigid polyester monofilament fabric. This belt is used in applications where a tough top cover is required to extend belt life. The pebbletop cover offers release for oily parts. It is a proven performer in stamping applications, carrying the blanks to the press.

SPEC#	PART#	TEMP.	THICKNESS	WEIGHT (PIW)	MIN. PULLEY	RECOMMENDED LACING
2-PLY 150# SPUN POLYESTER CLEAR URETHANE COVER X FRICTION						
4150	20104150	0°F to 180°F	0.1875"	0.090	4"	U2 Clipper®, #15 Alligator®, #187 Staple

A popular choice in a wide range of applications where cutting and abrasion are a concern.



SPEC#	PART#	TEMP.	THICKNESS	WEIGHT (PIW)	MIN. PULLEY	RECOMMENDED LACING
INTERWOVEN 90# POLYESTER RED URETHANE COVER X BRUSHED (NOVEX)						
90	24005272	20°F to 180°F	0.125"	0.075	2"	#25 Alligator®, #125 Staple
INTERWOVEN 120# POLYESTER RED URETHANE COVER X BRUSHED						
4151	20104151	0°F to 180°F	0.1875"	0.094	4"	U2 Clipper®, #20 Alligator®, #187 Staple
INTERWOVEN 200# POLYESTER RED URETHANE COVER X BRUSHED						
4176	20104176	0°F to 180°F	0.24"	1.400	6"	U4 Clipper®, #27 Alligator®, #187 Staple

Premium cover of urethane on an interwoven polyester carcass. This is the standard in many automotive stamping operations. Also highly recommended in many recycling plants and other abrasive jobs.

Note: The 90# allows for both finger and welded seam splices.



SPEC#	PART#	TEMP.	THICKNESS	WEIGHT (PIW)	MIN. PULLEY	RECOMMENDED LACING
NEEDED 135# POLYESTER GREEN NITRILE FRICTION X BRUSHED						
4154	20104154	10°F to 175°F	0.22"	0.070	5"	U3 Clipper®, #20 Alligator®, #187 Staple

Polyester uni-ply construction, impregnated with nitrile that offers excellent service in tough stamping operations. Excellent tracking and oil resistance.

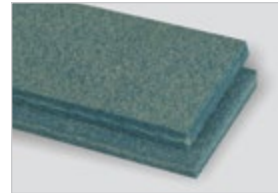

SPEC#	PART#	TEMP.	THICKNESS	WEIGHT (PIW)	MIN. PULLEY	RECOMMENDED LACING
NEEDED 135# POLYESTER BLACK NITRILE FRICTION X BRUSHED						
4180	20104180	10°F to 175°F	0.155"	0.040	2"	UX1 Clipper®, #7 Alligator®, #125 Staple

Special polyester uni-ply and needed polyester surfaces. Excellent tracking low-noise production and oil resistance are additional features.

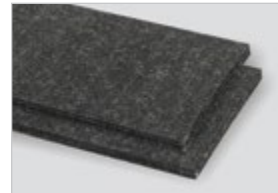

SPEC#	PART#	TEMP.	THICKNESS	WEIGHT (PIW)	MIN. PULLEY	RECOMMENDED LACING
2-PLY 150# POLYESTER GRAY BUTYL TEFLON® COVER X BARE						
4174	20104174	-40°F to 300°F	0.112"	0.650	2"	UX1 Clipper®, #7 Alligator®, #125 Staple

This unique belt has three plies of polyester with butyl skins for high temperatures. The Teflon® cover offers a highly durable dimpled cover with excellent release. Ideal for conveying hot, sticky products such as rubber, tapes and plastic extrusions. (Belt not FDA approved.)

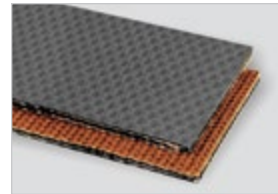

PVC
BELTING

DESCRIPTION
ABBREVIATION
KEY

PVC = Poly Vinyl
Chloride

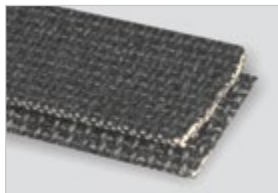

SPEC#	PART#	TEMP.	THICKNESS	WEIGHT (PIW)	MIN. PULLEY	RECOMMENDED LACING
INTERWOVEN 120# POLYESTER BLACK PVC FRICTION X BRUSHED						
5040	20105040	0°F to 180°F	0.109"	0.055	3"	UX1 Clipper®, #7 Alligator®, #125 Staple

Very popular specification for package and parcel handling. Low coefficient of friction on cover surfaces for easy accumulation of products. Tough, low stretch, excellent fastener and tracking properties.

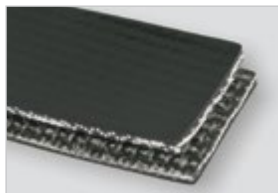

SPEC#	PART#	TEMP.	THICKNESS	WEIGHT (PIW)	MIN. PULLEY	RECOMMENDED LACING
INTERWOVEN 120# POLYESTER BLACK PVC COVER X BRUSHED						
5045	20105045	0°F to 180°F	0.125"	0.060	3"	UX1 Clipper®, #15 Alligator®, #125 Staple

Proven performer in a wide variety of applications: from warehousing, to fruit and vegetable packing houses; this is a popular choice. Tough, dependable and economical.



SPEC#	PART#	TEMP.	THICKNESS	WEIGHT (PIW)	MIN. PULLEY	RECOMMENDED LACING
INTERWOVEN 120# POLYESTER BLACK PVC COVER X COVER						
5042	20105042	0°F to 180°F	0.141"	0.080	3"	U3-1 Clipper®, #15 Alligator®, #125 Staple

Proven belt for long-wearing, high-performance, problem-free package handling applications. Ideal for moving palletized fertilizers and small-to medium-sized product loads. Also used for a variety of roller bed and troughed applications. Characteristics include low stretch, high strength, and good fastener retention.

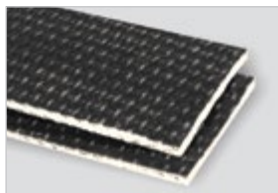

SPEC#	PART#	TEMP.	THICKNESS	WEIGHT (PIW)	MIN. PULLEY	RECOMMENDED LACING
INTERWOVEN 150# POLYESTER BLACK PVC FRICTION X BRUSHED						
5050	20105050	0°F to 180°F	0.156"	0.060	4"	UX1 Clipper®, #15 Alligator®, #125 Staple

Very popular specification for package and parcel handling. Low coefficient of friction on cover surfaces for easy accumulation of products. Tough, low stretch, excellent fastener and tracking properties, with higher tension rating for heavier loads.

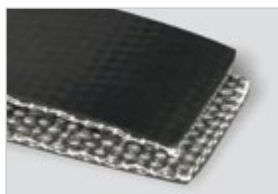

SPEC#	PART#	TEMP.	THICKNESS	WEIGHT (PIW)	MIN. PULLEY	RECOMMENDED LACING
INTERWOVEN 150# POLYESTER BLACK PVC COVER X BRUSHED						
5051	20105051	0°F to 180°F	0.172"	0.100	4"	U2 Clipper®, #20 Alligator®, #125 Staple

Very popular medium-duty PVC belt proven for long-wearing, high-performance, and problem-free material handling. Ideal for a variety of slider/roller bed applications. Accommodates fertilizers, chemicals, and bulk materials. Characteristics include low stretch, high strength, and good fastener retention.

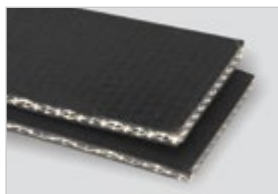

SPEC#	PART#	TEMP.	THICKNESS	WEIGHT (PIW)	MIN. PULLEY	RECOMMENDED LACING
INTERWOVEN 150# POLYESTER BLACK PVC COVER X COVER						
5052	20105052	0°F to 180°F	0.188"	0.110	4" (6" elevator)	U2 Clipper®, #20 Alligator®, #187 Staple

Proven belt for long-wearing, high-performance, problem-free material handling applications. Ideal for moving bulk materials, chemicals, fertilizers, and grain. Ideal for a variety of roller bed and troughed applications. Characteristics include low stretch, high strength, and good fastener retention.

SPEC#	PART#	TEMP.	THICKNESS	WEIGHT (PIW)	MIN. PULLEY	RECOMMENDED LACING
INTERWOVEN 200# POLYESTER BLACK PVC FRICTION X BRUSHED						
5060	20105060	0°F to 180°F	0.188"	0.125	6"	U3 Clipper®, #25 Alligator®, #187 Staple

High-strength, low-stretch belt for moving high volumes and heavy loads in package handling and parts conveying. Moderate oil resistance and excellent fastener retention.



SPEC#	PART#	TEMP.	THICKNESS	WEIGHT (PIW)	MIN. PULLEY	RECOMMENDED LACING
INTERWOVEN 200# POLYESTER BLACK PVC COVER X BRUSHED						
5061	20105061	0°F to 180°F	0.219"	0.130	6"	U4 Clipper®, #27 Alligator®, #187 Staple

Heavier-duty PVC belt proven for long-wearing, high-performance, and problem-free material handling. Also popular as heavy-duty package and bulk product conveyor belt for both slider and roller bed conveyors.

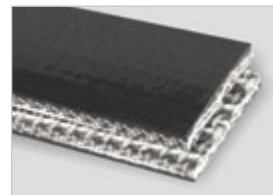

SPEC#	PART#	TEMP.	THICKNESS	WEIGHT (PIW)	MIN. PULLEY	RECOMMENDED LACING
INTERWOVEN 200# POLYESTER BLACK PVC COVER X COVER FR/SC						
5062	20105062	0°F to 180°F	0.25"	0.140	7"	#27 Alligator®, #187 Staple, #R5 Rivet

PVC offers reliable performance in applications such as bulk handling, heavy stamping, scrap, wood products, sand & gravel, and vertical elevators. Like the medium-duty PVC belts, these products are the most economical choice in the widest range of applications. Fire-retardant and static-conductive qualities.

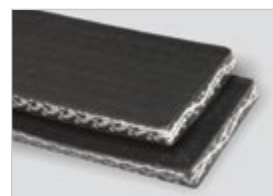

SPEC#	PART#	TEMP.	THICKNESS	WEIGHT (PIW)	MIN. PULLEY	RECOMMENDED LACING
INTERWOVEN 250# POLYESTER BLACK PVC COVER X COVER FR/SC						
5065	20105065	0°F to 180°F	0.266"	0.145	7" (9" elevator)	#140 Solid Plate, #550 Bolt On, #R5 Rivet

Commonly used for elevator belting in the feed and grain industries. Oil-resistant, fire-retardant and static-conductive qualities. This belt will not mildew or rot, MSHA approved, moisture-resistant, and has high bolt retention for bucket attachments.

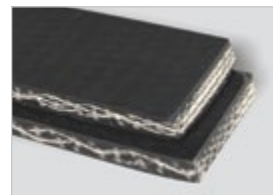

SPEC#	PART#	TEMP.	THICKNESS	WEIGHT (PIW)	MIN. PULLEY	RECOMMENDED LACING
INTERWOVEN 350# POLYESTER BLACK PVC COVER X COVER FR/SC						
5072	20105072	0°F to 180°F	0.313"	0.150	8"	#140 Solid Plate, #550 Bolt On, #R5 Rivet

Fire-retardant, static-conductive belt commonly used for elevator belting in the feed and grain industries. Features low-stretch, trouble-free operation, high bolt retention, resistant to grain oils, fire, moisture, and mildew. MSHA approved.

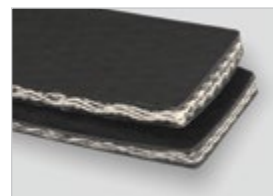

SPEC#	PART#	TEMP.	THICKNESS	WEIGHT (PIW)	MIN. PULLEY	RECOMMENDED LACING
INTERWOVEN 450# POLYESTER BLACK PVC COVER X COVER FR/SC						
73	20040009	0°F to 180°F	0.344"	0.160	10"	#45 Alligator®

Commonly used for elevator belting in the feed and grain industries. Features low-stretch, trouble-free operation, high bolt retention, resistant to grain oils, fire, moisture, mildew, and rot. MSHA approved.

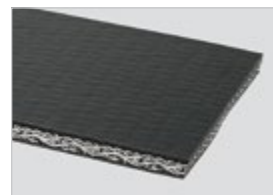

DESCRIPTION ABBREVIATION KEY

FR = Fire Retardant

PVC = Poly Vinyl Chloride

SC = Static Conductive

DESCRIPTION
ABBREVIATION
KEY

PVC = Poly Vinyl
Chloride

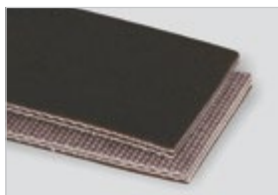

SPEC#	PART#	TEMP.	THICKNESS	WEIGHT (PIW)	MIN. PULLEY	RECOMMENDED LACING
2-PLY 150# POLYESTER BLACK PVC MATTE COVER X BRUSHED						
4144	20104144	-20°F to 180°F	0.172"	0.100	4"	U2 Clipper®, #15 Alligator®, #187 Staple

Medium-duty utility PVC belt designed for a wide variety of industrial and agricultural applications. High-resin PVC offers a premium cover compound that is easily fabricated using thermoweld and high-frequency equipment. This compound also makes this belt an excellent alternative to similar rubber products.



SPEC#	PART#	TEMP.	THICKNESS	WEIGHT (PIW)	MIN. PULLEY	RECOMMENDED LACING
2-PLY 150# POLYESTER BLACK PVC MATTE COVER X MATTE COVER						
4146	20104146	-20°F to 180°F	0.188"	0.110	5"	U2 Clipper®, #15 Alligator®, #187 Staple

Medium-duty utility PVC belt designed for a wide variety of industrial and agricultural applications. High-resin PVC offers a premium cover compound that is easily fabricated using thermoweld and high-frequency equipment. This compound also makes this belt an excellent alternative to similar rubber products.



SPEC#	PART#	TEMP.	THICKNESS	WEIGHT (PIW)	MIN. PULLEY	RECOMMENDED LACING
INTERWOVEN 120# POLYESTER BLACK PVC CHEVRON TOP X BRUSHED						
4324	20104324	20°F to 180°F	0.25"	0.080	3"	UX1 Clipper®, #15 Alligator®, #125 Staple
INTERWOVEN 200# POLYESTER BLACK PVC CHEVRON TOP X BRUSHED						
4338	20104338	20°F to 180°F	0.344"	0.140	6"	U4 Clipper®, #27 Alligator®, #187 Staple

The herringbone pattern of alternating rows of solid PVC chevron profiles form a cover capable of moving free-flowing bulk solids. Materials such as grains, food stuffs, feeds and fertilizers can be carried up steep inclines. The chevron shape assists in draining liquids from wet products.

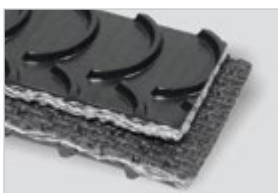

SPEC#	PART#	TEMP.	THICKNESS	WEIGHT (PIW)	MIN. PULLEY	RECOMMENDED LACING
INTERWOVEN 120# POLYESTER BLACK PVC CRESCENT TOP X BRUSHED						
4327	20104327	20°F to 180°F	0.24"	0.089	2"	UX1 Clipper®, #27 Alligator®, #187 Staple
INTERWOVEN 200# POLYESTER BLACK PVC CRESCENT TOP X BRUSHED						
185	20035530	20°F to 180°F	0.344"	0.130	6"	U4 Clipper®, #27 Alligator®, #187 Staple

Crescent top profiles project from the belt surface to aggressively assist the belt in moving bulk solids. By running the belt in the opposite direction, the crescent shapes can assist in draining liquids from wet products. Crescents overlap to assure smooth, quiet running on return rolls. For heavier and wider loads we recommend the 200# fabric.



SPEC#	PART#	TEMP.	THICKNESS	WEIGHT (PIW)	MIN. PULLEY	RECOMMENDED LACING
INTERWOVEN 120# POLYESTER BLACK PVC Z-TOP X BRUSHED						
4329	20104329	20°F to 180°F	0.245"	0.090	3"	UX1 Clipper®, #15 Alligator®, #125 Staple

Very sturdy and aggressive impression tops incline belt used in agricultural applications as well as chemical, fertilizer and industrial applications. The impression is deep enough to increase load capacity up inclines but designed in shapes that allow the belt to run smoothly on the conveyor return rollers.

DESCRIPTION
ABBREVIATION
KEY

PVC = Poly Vinyl Chloride

SPEC#	PART#	TEMP.	THICKNESS	WEIGHT (PIW)	MIN. PULLEY	RECOMMENDED LACING
2-PLY 100# POLYESTER MONOFILAMENT BLACK PVC V-RUNNER X BARE						
4328	20104328	20°F to 180°F	0.093"	0.065	1.5"	UX1SP Clipper®, #7 Alligator®, #62 Staple
NEEDED 120# POLYESTER BLACK PVC V-RUNNER X BRUSHED						
4340	20104340	20°F to 180°F	0.155"	0.065	1.5"	U2SP Clipper®, #7 Alligator®, #125 Staple



An incline belt with a premium high-grip PVC-grooved cover for use on low-profile applications. Used in dirty, dusty conditions, occasional cleaning will restore the high-grip action.

SPEC#	PART#	TEMP.	THICKNESS	WEIGHT (PIW)	MIN. PULLEY	RECOMMENDED LACING
2-PLY 100# POLYESTER MONOFILAMENT GRAY PVC V-RUNNER X BARE						
4326	20104326	20°F to 180°F	0.094"	0.050	1.5"	UX1SP Clipper®, #7 Alligator®, #62 Staple

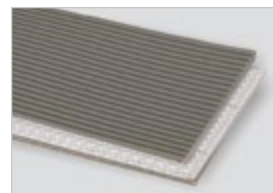

V-Runner's premium PVC top cover utilizes longitudinal grooves to achieve its aggressive grip. Can be easily finger spliced resulting in top-quality endless belts. In dirty and dusty conditions, occasional cleaning restores the gripping action.

SPEC#	PART#	TEMP.	THICKNESS	WEIGHT (PIW)	MIN. PULLEY	RECOMMENDED LACING
2-PLY 90# POLYESTER MONOFILAMENT GRAY PVC SNAKE SKIN STICKY TOP X BARE						
4162	20104162	20°F to 180°F	0.125"	0.053	2"	UX1SP Clipper®, #7 Alligator®, #62 Staple

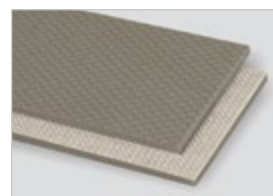

Specialty high-friction tops used in difficult inclines, declines or as brake or spacer belts. Can handle paperboard containers and some totes on inclines up to 45°. Primarily effective in clean, dry environments. This series of belts is made with premium soft durometer PVC covers.

SPEC#	PART#	TEMP.	THICKNESS	WEIGHT (PIW)	MIN. PULLEY	RECOMMENDED LACING
2-PLY 65# POLYESTER MONOFILAMENT GRAY PVC SMOOTH STICKY TOP X BARE						
4160	20104160	20°F to 180°F	0.125"	0.060	1.5"	UX1 Clipper®, #7 Alligator®, #62 Staple

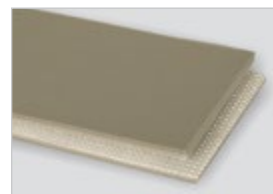

Specialty high-friction tops used in difficult inclines, declines or as brake or spacer belts. Can handle paperboard containers and some totes on inclines up to 45°. Primarily effective in clean, dry environments. This series of belts is made with premium soft durometer PVC covers.

SPEC#	PART#	TEMP.	THICKNESS	WEIGHT (PIW)	MIN. PULLEY	RECOMMENDED LACING
3-PLY 135# POLYESTER MONOFILAMENT GRAY PVC SMOOTH STICKY TOP X BARE						
4163	20104163	20°F to 180°F	0.185"	0.098	3"	U2 Clipper®, #15 Alligator®, #187 Staple

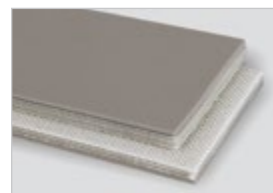

Specialty high-friction tops used in difficult inclines, declines or as brake or spacer belts. Can handle paperboard containers and some totes on inclines up to 45°. Primarily effective in clean, dry environments. This series of belts is made with premium soft durometer PVC covers.

SPEC#	PART#	TEMP.	THICKNESS	WEIGHT (PIW)	MIN. PULLEY	RECOMMENDED LACING
2-PLY 100# POLYESTER MONOFILAMENT BLACK PVC LATTICE TOP X BARE						
4367	20104367	20°F to 180°F	0.12"	0.050	2"	UX1SP Clipper®, #7 Alligator®, #62 Staple



DESCRIPTION
ABBREVIATION
KEY

PVC = Poly Vinyl
Chloride

SBR = Styrene
Butadiene Rubber



SPEC#	PART#	TEMP.	THICKNESS	WEIGHT (PIW)	MIN. PULLEY	RECOMMENDED LACING
2-PLY 100# SPUN POLYESTER BLACK PVC PEBBLETOP X FRICTION						
4392	20104392	20°F to 180°F	0.115"	0.070	1.5"	UX1 Clipper®, #7 Alligator®, #125 Staple

Pebbletop impression is used when more traction is called for, but a rougtop belt is too much. Popular in wood products and metal stamping.

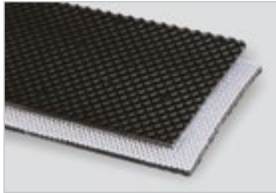

SPEC#	PART#	TEMP.	THICKNESS	WEIGHT (PIW)	MIN. PULLEY	RECOMMENDED LACING
2-PLY 100# POLYESTER MONOFILAMENT BLACK PVC QUAD TOP X BARE						
4393	20104393	20°F to 180°F	0.074"	0.035	1"	UX1SP Clipper®, #7 Alligator®, #62 Staple

Traditional quad (inverted diamond) pattern makes this polyester monofilament belt a great choice as an alternative to standard rougtops when a less aggressive cover is required. More easily cleaned, this belt is popular in a wide range of industrial applications. Thermoplastic elastomer allows for easy splicing and fabrication including cleats and V-guides.

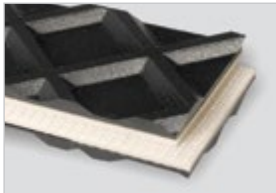

SPEC#	PART#	TEMP.	THICKNESS	WEIGHT (PIW)	MIN. PULLEY	RECOMMENDED LACING
3-PLY 150# POLYESTER MONOFILAMENT BLACK PVC WAFFLE TOP X BARE						
4383	20104383	20°F to 180°F	0.335"	0.036	4.72"	U2 Clipper®, #20 Alligator®, #187 Staple

This unique belt was designed with a square diamond, permanently anti-static, oil-resistant cover that is ideal for box rail applications as well as sanding and woodworking machines.

INCLINE
BELTING

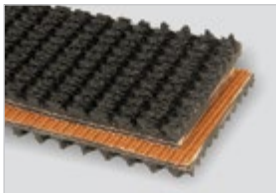

SPEC#	PART#	TEMP.	THICKNESS	WEIGHT (PIW)	MIN. PULLEY	RECOMMENDED LACING
2-PLY 150# POLYESTER BLACK SBR ROUGHTOP X BARE						
4301	20104301	0°F to 250°F	0.281"	0.110	2"	UX1 Clipper®, #7 Alligator®, #125 Staple

Popular standard rougtop belt that can be used as pulley lagging. Features a deep, nonskid hemp impression rougtop surface that enables products to be conveyed on inclines and declines. Popular for strip lagging pulleys.

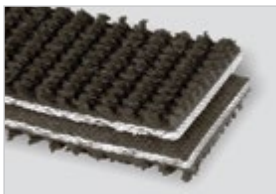

SPEC#	PART#	TEMP.	THICKNESS	WEIGHT (PIW)	MIN. PULLEY	RECOMMENDED LACING
3-PLY 105# COTTON/POLYESTER BLACK SBR ROUGHTOP X BARE						
4302	20104302	0°F to 250°F	0.312"	0.118	2.5"	U2 Clipper®, #15 Alligator®, #187 Staple

Constructed of three plies of cotton/polyester carcass. Excellent tracking characteristics and high grip capabilities.



SPEC#	PART#	TEMP.	THICKNESS	WEIGHT (PIW)	MIN. PULLEY	RECOMMENDED LACING
2-PLY 150# POLYESTER TAN SBR ROUGHTOP X BARE						
4303	20104303	0°F to 250°F	0.25"	0.092	2"	UX1 Clipper®, #7 Alligator®, #125 Staple

Tan non-marking rougtop surface. Soft durometer compound provides extra gripping power.

SPEC#	PART#	TEMP.	THICKNESS	WEIGHT (PIW)	MIN. PULLEY	RECOMMENDED LACING
2-PLY 150# POLYESTER TAN NATURAL RUBBER ROUGHTOP X BARE						
4304	20104304	0°F to 250°F	0.265"	0.094	2"	UX1SP Clipper®, #7 Alligator®, #125 Staple
3-PLY 225# POLYESTER TAN NATURAL RUBBER ROUGHTOP X BARE						
4305	20104305	0°F to 250°F	0.281"	0.090	3"	UX1 Clipper®, #15 Alligator®, #125 Staple



Gum rubber rough tops have been a standard in paper industries as well as package handling. Soft pure gum cover provides a very aggressive and extended wear top cover. Still popular in some paperboard and box plant applications.

SPEC#	PART#	TEMP.	THICKNESS	WEIGHT (PIW)	MIN. PULLEY	RECOMMENDED LACING
3-PLY 150# POLYESTER BLUE CARBOXYLATED NITRILE ROUGHTOP X FRICTION						
4307	20104307	0°F to 250°F	0.313"	0.116	4"	U2 Clipper®, #15 Alligator®, #187 Staple

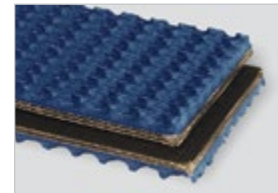

Carboxylated nitrile rough top provides superior service with longer wear and better cut and gouge resistance than standard compounds used in general purpose rough top specifications. Excellent abrasion-resistant properties. Popular for box board conveying.

SPEC#	PART#	TEMP.	THICKNESS	WEIGHT (PIW)	MIN. PULLEY	RECOMMENDED LACING
3-PLY 150# POLYESTER/NYLON BLUE CARBOXYLATED NITRILE ROUGHTOP X BARE						
4377	20104377	0°F to 250°F	0.313"	0.125	4"	U2 Clipper®, #15 Alligator®, #187 Staple

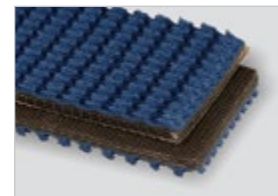

Good choice for high-wear and abrasive applications. Oil-grease-and chemical-resistant. Popular for metal stamping, corrugated box and paper conversion applications.

SPEC#	PART#	TEMP.	THICKNESS	WEIGHT (PIW)	MIN. PULLEY	RECOMMENDED LACING
2-PLY 90# MULTIFILAMENT BLUE CARBOXYLATED NITRILE ROUGHTOP X BARE						
4330	20104330	0°F to 250°F	0.26"	0.106	2"	UX1 Clipper®, #7 Alligator®, #125 Staple

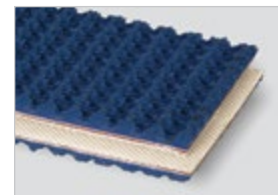

Versatile, flexible and tough light-duty belt built to withstand oil, grease and abrasion. Able to wrap small pulleys, and multifilament carcass is easy to splice.

SPEC#	PART#	TEMP.	THICKNESS	WEIGHT (PIW)	MIN. PULLEY	RECOMMENDED LACING
3-PLY 225# POLYESTER RED CARBOXYLATED NITRILE ROUGHTOP X BARE						
4360	20104360	0°F to 250°F	0.309"	0.106	3"	U2 Clipper®, #15 Alligator®, #187 Staple



Heavy-duty, non-marking rough top belt that withstands the effects of oil, grease and abrasion. Popular for high-wear applications for corrugated boxes and conversion applications.

SPEC#	PART#	TEMP.	THICKNESS	WEIGHT (PIW)	MIN. PULLEY	RECOMMENDED LACING
3-PLY 150# POLYESTER/NYLON ORANGE CARBOXYLATED NITRILE ROUGHTOP X BARE						
4309	20104309	0°F to 250°F	0.313"	0.105	4"	U2 Clipper®, #15 Alligator®, #187 Staple



DESCRIPTION
ABBREVIATION
KEY

PVC = Poly Vinyl
Chloride



SPEC#	PART#	TEMP.	THICKNESS	WEIGHT (PIW)	MIN. PULLEY	RECOMMENDED LACING
3-PLY 150# POLYESTER/NYLON BROWN NITRILE ROUGHTOP X BARE						
4308	20104308	0°F to 250°F	0.313"	0.100	2.5"	UX1 Clipper®, #15 Alligator®, #125 Staple

An excellent choice for oil, heat, grease or chemical resistance. Extremely strong yet flexible. This belt is often used for oily parts and light-stamping applications where sharp parts are taken up inclines to hoppers or scrap bins.



SPEC#	PART#	TEMP.	THICKNESS	WEIGHT (PIW)	MIN. PULLEY	RECOMMENDED LACING
3-PLY 150# POLYESTER TAN NITRILE ROUGHTOP X FRICTION						
4351	20104351	0°F to 250°F	0.272"	0.080	2"	U2 Clipper®, #15 Alligator®, #187 Staple

Premium roughtop belt with excellent oil and abrasion resistance. Nitrile also provides good temperature resistance.

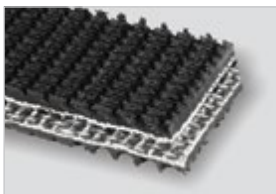

SPEC#	PART#	TEMP.	THICKNESS	WEIGHT (PIW)	MIN. PULLEY	RECOMMENDED LACING
INTERWOVEN 120# POLYESTER BLACK PVC ROUGHTOP X FRICTION						
4321	20104321	20°F to 180°F	0.313"	0.080	3"	UX1 Clipper®, #7 Alligator®, #125 Staple
INTERWOVEN 150# POLYESTER BLACK PVC ROUGHTOP X FRICTION						
61B	20035509	20°F to 180°F	0.203"	0.113	3"	#2 Clipper®, #20 Alligator®, #125 Staple

Our PVC roughtop cover has non-skid surface that enables packages, boxes and cases to be conveyed in both incline and declines. Solid woven polyester carcass has high strength and low stretch capabilities.

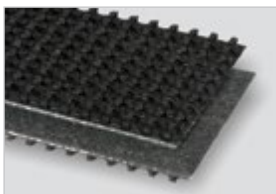

SPEC#	PART#	TEMP.	THICKNESS	WEIGHT (PIW)	MIN. PULLEY	RECOMMENDED LACING
NEEDED 120# POLYESTER BLACK PVC ROUGHTOP X BRUSHED						
4391	20104391	20°F to 180°F	0.219"	0.075	2.5"	UX1 Clipper®, #7 Alligator®, #125 Staple

Medium-duty PVC roughtop cover has non-skid surface that enables packages, boxes and cases to be conveyed in both incline and declines. Needed polyester carcass offers low stretch and quiet weave construction.

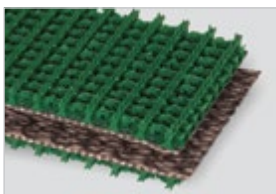

SPEC#	PART#	TEMP.	THICKNESS	WEIGHT (PIW)	MIN. PULLEY	RECOMMENDED LACING
INTERWOVEN 120# POLYESTER GREEN PVC EXTRA GRIP ROUGHTOP X BARE						
4322	20104322	20°F to 180°F	0.313"	0.080	3"	UX1 Clipper®, #7 Alligator®, #125 Staple

Top cover features non-marking, soft PVC compound for extra grab on challenging incline and decline applications. High-performance and economical price.



SPEC#	PART#	TEMP.	THICKNESS	WEIGHT (PIW)	MIN. PULLEY	RECOMMENDED LACING
INTERWOVEN 170# POLYESTER RED PVC ROUGHTOP X FRICTION						
4357	20104357	20°F to 180°F	0.34"	0.095	4"	U2 Clipper®, #15 Alligator®, #187 Staple

Tough, durable and low-stretch carcass combined with tough PVC cover provides moderate oil and chemical resistance. Very popular for transporting OSB/particle boards and in the plywood industry.

DESCRIPTION ABBREVIATION KEY

PVC = Poly Vinyl Chloride

SBR = Styrene Butadiene Rubber

SPEC#	PART#	TEMP.	THICKNESS	WEIGHT (PIW)	MIN. PULLEY	RECOMMENDED LACING
2-PLY 100# POLYESTER MONOFILAMENT GREEN PVC ROUGHTOP X BARE						
4346	20104346	20°F to 180°F	0.219"	0.080	2.4"	U2 Clipper®, #7 Alligator®, #125 Staple

Soft, high-grip top PVC cover with plied polyester monofilament carcass to wrap small pulley diameters and low-stretch features.

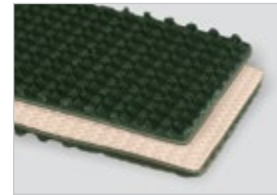

SPEC#	PART#	TEMP.	THICKNESS	WEIGHT (PIW)	MIN. PULLEY	RECOMMENDED LACING
2-PLY 100# POLYESTER MONOFILAMENT GREEN PVC EXW ROUGHTOP X BARE						
4350	20104350	20°F to 180°F	0.219"	0.080	2.4"	U2 Clipper®, #7 Alligator®, #125 Staple

PVC top cover popular in distribution/sorting centers. Unique sine wave (EXW) cover is designed for low noise and allows the belt to run quieter on return idlers.

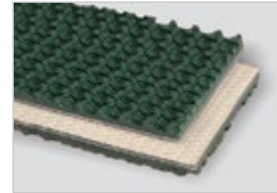

SPEC#	PART#	TEMP.	THICKNESS	WEIGHT (PIW)	MIN. PULLEY	RECOMMENDED LACING
3-PLY 150# POLYESTER/NYLON BROWN NITRILE V-TOP X FRICTION						
4310	20104310	20°F to 212°F	0.297"	0.095	4"	U2 Clipper®, #15 Alligator®, #125 Staple

One of the more aggressive rough top belts on the market. V-top can take corrugated packages up inclines as steep as 45°. For slick plastic tote applications this is a belt worth consideration. Excellent oil resistance.



SPEC#	PART#	TEMP.	THICKNESS	WEIGHT (PIW)	MIN. PULLEY	RECOMMENDED LACING
3-PLY 150# POLYESTER/NYLON TAN PURE GUM V-TOP X FRICTION						
4311	20104311	-30°F to 180°F	0.297"	0.080	4"	#2 Clipper®, #25 Alligator®, #125 Staple

Soft gum rubber surface allows for exceptional gripping power to convey packages and totes in high-incline and decline applications.



SPEC#	PART#	TEMP.	THICKNESS	WEIGHT (PIW)	MIN. PULLEY	RECOMMENDED LACING
3-PLY 105# COTTON/POLYESTER BLACK SBR V-TOP X FRICTION						
4312	20104312	0°F to 250°F	0.313"	0.120	2.5"	U2 Clipper®, #15 Alligator®, #125 Staple

Profile features 1/4" tall high rubber nubs with V-notches for extra gripping power. Great for handling packages, plastic totes and bagged goods.

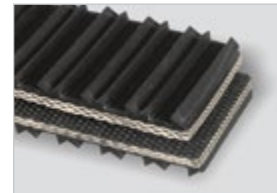

SPEC#	PART#	TEMP.	THICKNESS	WEIGHT (PIW)	MIN. PULLEY	RECOMMENDED LACING
2-PLY 150# POLYESTER TAN SBR SIPED DIAMOND TOP X BARE						
4313	20104313	0°F to 250°F	0.281"	0.090	3"	U2 Clipper®, #15 Alligator®, #125 Staple
3-PLY 240# POLYESTER TAN SBR DIAMOND TOP X BARE						
4374	20104374	0°F to 250°F	0.313"	0.111	4"	U2 Clipper®, #15 Alligator®, #187 Staple

Sometimes referred to as "wedgegrip", our tan non-marking diamond-shaped profiled design has high coefficient of friction for exceptional gripping capabilities. Popular for cases, parcels and bagged goods.



DESCRIPTION
ABBREVIATION
KEY

SBR = Styrene
Butadiene Rubber



SPEC#	PART#	TEMP.	THICKNESS	WEIGHT (PIW)	MIN. PULLEY	RECOMMENDED LACING
2-PLY 150# POLYESTER BLACK SBR SIPED DIAMOND TOP X BARE						
4314	20104314	0°F to 250°F	0.313"	0.090	4"	U2 Clipper®, #15 Alligator®, #125 Staple
3-PLY 225# POLYESTER BLACK SBR DIAMOND TOP X BARE						
4375	20104375	0°F to 250°F	0.313"	0.115	5"	U2 Clipper®, #15 Alligator®, #187 Staple

Sometimes referred to as "wedgrip", our diamond-shaped profiled design has high coefficient of friction for exceptional gripping capabilities. Popular for cases, parcels and bagged goods. It is also used for aftermarket belts for the US post office.



SPEC#	PART#	TEMP.	THICKNESS	WEIGHT (PIW)	MIN. PULLEY	RECOMMENDED LACING
3-PLY 90# COTTON/POLYESTER TAN NATURAL RUBBER STEEP-GRADE X FRICTION						
4315	20104315	0°F to 250°F	0.315"	0.104	2.5"	U2 Clipper®, #15 Alligator®, #125 Staple

Oval-shaped nubs on top cover is a popular choice for high-angle inclines and declines. The unique cover design prevents slippage of products, as well as cushioning protection for boxes, cartons and packaged goods.



SPEC#	PART#	TEMP.	THICKNESS	WEIGHT (PIW)	MIN. PULLEY	RECOMMENDED LACING
2-PLY 150# POLYESTER BLACK SBR STEEP-GRADE X BARE						
4317	20104317	0°F to 250°F	0.287"	0.099	2"	U2 Clipper®, #15 Alligator®, #125 Staple
3-PLY 90# COTTON/POLYESTER BLACK SBR STEEP-GRADE X FRICTION						
4334	20104334	0°F to 250°F	0.315"	0.095	2.5"	U2 Clipper®, #15 Alligator®, #125 Staple

Oval-shaped nubs on top cover is a popular choice for high-angle inclines and declines. The unique cover design prevents slippage of products, as well as cushioning protection for boxes, cartons and packaged goods.

BELT CONSTRUCTION

We have a vast selection of heavy-duty belting products with a broad range of tension ratings and cover compounds to handle a wide variety of products:

- ▶ Popular, durable constructions
- ▶ Standard grade 2 covers for abrasion resistance
- ▶ Grade 1 covers for impact and tear resistance
- ▶ Moderate and super oil-resistant specs
- ▶ High-temperature, fire-retardant, and static-conductive constructions
- ▶ Plyed and straight warp carcasses available to meet specific application needs

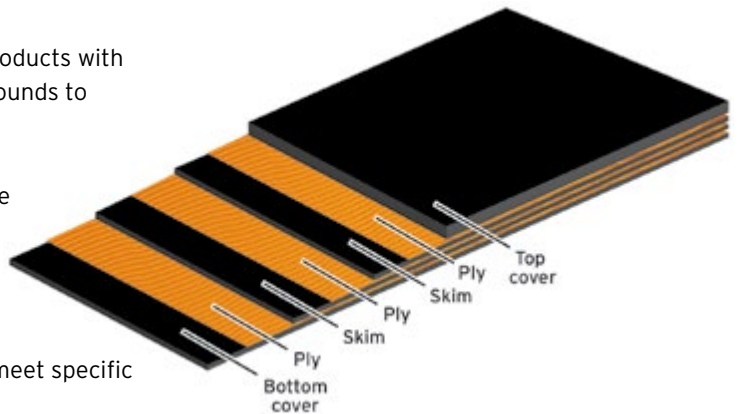

INDUSTRIAL
BELTING



SPEC#	PART#	TEMP.	THICKNESS	WEIGHT (PIW)	MIN. PULLEY	RECOMMENDED LACING
2-PLY 150# 1/32 X BARE BACK GRADE 2						
1	20027202	-25°F to 225°F	5/32"	0.075	4"	#2 Clipper®, #15 Alligator®, #125 Staple

Standard-grade rubber covers resist abrasion and weathering in non-oily applications. Used as an economical general purpose belt and popular in many agricultural applications, including potato conveying and transport on slider beds.



SPEC#	PART#	TEMP.	THICKNESS	WEIGHT (PIW)	MIN. PULLEY	RECOMMENDED LACING
2-PLY 150# 1/32 X 1/32 GRADE 2						
2	20027301	-25°F to 225°F	13/64"	0.085	4"	#3 Clipper®, #25 Alligator®, #187 Staple

Standard-grade rubber covers for light-duty unit and bulk handling applications. Popular fabricated belting for transporting potatoes, wood products, and light bulk materials.



SPEC#	PART#	TEMP.	THICKNESS	WEIGHT (PIW)	MIN. PULLEY	RECOMMENDED LACING
2-PLY 150# 1/8 X 1/32 GRADE 2						
3	20000010	-25°F to 225°F	1/4"	0.138	8"	#140 Solid Plate, #375 Bolt On, #R2 Rivet

Popular and versatile choice for small-capacity conveyors. Durable covers and flexible carcass allow belt to wrap small pulley diameters.



SPEC#	PART#	TEMP.	THICKNESS	WEIGHT (PIW)	MIN. PULLEY	RECOMMENDED LACING
2-PLY 220# 1/8 X BARE BACK GRADE 2						
6A	20029525	-25°F to 225°F	1/4"	0.145	10"	#187 Staple, #140 Solid Plate, #375 Bolt On, #R2 Rivet

SPEC#	PART#	TEMP.	THICKNESS	WEIGHT (PIW)	MIN. PULLEY	RECOMMENDED LACING
2-PLY 220# 1/8 X 1/16 GRADE 2						
8	20013600	-25°F to 225°F	5/16"	0.167	10"	#140 Solid Plate, #550 Bolt On, #R5 Rivet

Popular and versatile belt for medium-duty applications. Grade 2 covers provide excellent abrasion resistance and durability.



SPEC#	PART#	TEMP.	THICKNESS	WEIGHT (PIW)	MIN. PULLEY	RECOMMENDED LACING
2-PLY 220# 3/16 X 1/16 GRADE 2						
9	20017500	-25°F to 225°F	11/32"	0.195	12"	#140 Solid Plate, #550 Bolt On, #R5 Rivet

One of the most popular belts in today's marketplace. Widely used to handle aggregate and other abrasive materials. 3/16" top cover offers durability and long belt life.



SPEC#	PART#	TEMP.	THICKNESS	WEIGHT (PIW)	MIN. PULLEY	RECOMMENDED LACING
3-PLY 330# 3/16 X 1/16 GRADE 2						
11	20023005	-25°F to 225°F	13/32"	0.205	16"	#190 Solid Plate, #550 Bolt On, #R5-1/2 Rivet

Very popular belt used extensively to transport rock, sand, and gravel. Tough polyester/nylon carcass and abrasion-resistant grade 2 covers for needed durability.



SPEC#	PART#	TEMP.	THICKNESS	WEIGHT (PIW)	MIN. PULLEY	RECOMMENDED LACING
3-PLY 330# 1/4 X 1/16 GRADE 2						
12	20026039	-25°F to 225°F	15/32"	0.215	16"	#190 Solid Plate, #550 Bolt On, #R5-1/2 Rivet

Popular heavy-duty belt where additional top-cover protection is needed for better abrasion and gouge resistance. Widely used in aggregate and mining applications.



SPEC#	PART#	TEMP.	THICKNESS	WEIGHT (PIW)	MIN. PULLEY	RECOMMENDED LACING
4-PLY 440# 1/4 X 1/16 GRADE 2						
13	20026815	-25°F to 225°F	9/16"	0.280	20"	#190 Solid Plate, #550 Bolt On, #R6 Rivet

Excellent heavy-duty belt when higher tensions are required and to support wide loads. Thick top cover withstands impact, cutting, and gouging.



SPEC#	PART#	TEMP.	THICKNESS	WEIGHT (PIW)	MIN. PULLEY	RECOMMENDED LACING
2-PLY 400# 5/16 X 1/16 GRADE 2						
15	20017538	-25°F to 225°F	1/2"	0.300	16"	#140 Solid Plate, #550 Bolt On, #R5 Rivet

A popular heavy-duty belt, particularly in confined spaces with limited clearances. This belt is an excellent replacement for 3-ply 330#; can wrap a 16" diameter head pulley, but provides a heavier top cover, higher strength and greater durability. Very popular for primary and mobile crushers in the aggregate industry.





SPEC#	PART#	TEMP.	THICKNESS	WEIGHT (PIW)	MIN. PULLEY	RECOMMENDED LACING
1-PLY 440# 1/4 X 1/8 GRADE 1						
246A	20029850	-25°F to 225°F	9/16"	0.295	20"	#190 Solid Plate, #550 Bolt On, #R6 Rivet

A straight warp synthetic carcass made especially to withstand abrasive applications. Thick, grade 1, single-ply construction offers exceptional life, low stretch, high load-carrying capacity, and can withstand high impact, tearing, and gouging.



SPEC#	PART#	TEMP.	THICKNESS	WEIGHT (PIW)	MIN. PULLEY	RECOMMENDED LACING
3-PLY 600# 3/8 X 3/32 GRADE 1						
14B	20241012	-25°F to 225°F	23/32"	0.375	24"	#1-1/2" Solid Plate, #R6 Rivet

High tension belt for handling heavy material, higher tonnages and large lump sizes. Extra-thick grade 1 cover. Withstands high impact as well as tearing and gouging from sharp/heavy material.



SPEC#	PART#	TEMP.	THICKNESS	WEIGHT (PIW)	MIN. PULLEY	RECOMMENDED LACING
2-PLY 220# 1/8 X BARE BACK MODERATE OIL RESISTANCE						
26C	20029690	0°F to 250°F	1/4"	0.150	10"	#187 Staple, #140 Solid Plate, #375 Bolt On, #R2 Rivet

Very versatile belt used extensively in recycling applications to withstand the effects of light oils, chemicals, and greases. Stocked in a variety of widths up to 84".

GRAIN
BELTING



SPEC#	PART#	TEMP.	THICKNESS	WEIGHT (PIW)	MIN. PULLEY	RECOMMENDED LACING
2-PLY 150# 1/32 X BARE BACK MODERATE OIL RESISTANCE						
21	20027200	0°F to 250°F	9/64"	0.075	4"	#2 Clipper®, #15 Alligator®, #125 Staple

Popular choice for conveyors requiring small pulleys and low capacity. Often used in moderately oily applications such as agriculture and wood waste.



SPEC#	PART#	TEMP.	THICKNESS	WEIGHT (PIW)	MIN. PULLEY	RECOMMENDED LACING
3-PLY 330# 1/16 X 1/16 STATIC CONDUCTIVE OIL RESISTANT FIRE RETARDANT GRAIN						
25A	20021630	0°F to 250°F	17/64"	0.130	16" (18" elevator)	#140 Solid Plate, #550 Bolt On, #R5 Rivet

Special compounds in this belt make it an excellent choice for handling grain and other applications requiring resistance to mineral, animal, or vegetable fats. It is also static-conductive for use on grain conveyors and in grain elevators where static charges must be held to minimums. Belt is flame-retardant.



SPEC#	PART#	TEMP.	THICKNESS	WEIGHT (PIW)	MIN. PULLEY	RECOMMENDED LACING
3-PLY 600# 1/16 X 1/16 STATIC CONDUCTIVE OIL RESISTANT FIRE RETARDANT GRAIN						
27A	20021635	0°F to 250°F	3/8"	0.195	20" (24" elevator)	#140 Solid Plate, #550 Bolt On, #R5 Rivet

Special compounds in this belt make it an excellent choice for handling grain and other applications requiring resistance to mineral, animal, or vegetable fats. It is also static-conductive for use on grain

SPEC#	PART#	TEMP.	THICKNESS	WEIGHT (PIW)	MIN. PULLEY	RECOMMENDED LACING
2-PLY 220# 3/16 X 1/16 MODERATE OIL RESISTANCE						
24B	20017332	0°F to 250°F	11/32"	0.200	12"	#190 Solid Plate, #550 Bolt On, #R5 Rivet

Popular belt for applications requiring moderate oil-resistant covers; such as waste water treatment, recycling, wood chips and some grains.



SPEC#	PART#	TEMP.	THICKNESS	WEIGHT (PIW)	MIN. PULLEY	RECOMMENDED LACING
3-PLY 330# 3/16 X 1/16 MODERATE OIL RESISTANCE						
26A	20021820	0°F to 250°F	13/32"	0.220	16"	#190 Solid Plate, #550 Bolt On, #R5 Rivet

Heavy-duty belt for applications requiring moderate oil-resistant covers; such as recycling, wood chips, and some grains.



SPEC#	PART#	TEMP.	THICKNESS	WEIGHT (PIW)	MIN. PULLEY	RECOMMENDED LACING
3-PLY 330# 3/16 X BARE BACK MODERATE OIL RESISTANCE						
26B	20029734	0°F to 250°F	11/32"	0.180	16"	#190 Solid Plate, #375 Bolt On, #R5 Rivet

Versatile heavy-duty belt with thick 3/16" moderate oil-resistant top cover and bare bottom to operate on slider beds and metal pans. Popular for recycling and wood products.



SPEC#	PART#	TEMP.	THICKNESS	WEIGHT (PIW)	MIN. PULLEY	RECOMMENDED LACING
2-PLY 220# 3/16 X 1/16 400° MAXI-HEAT						
41	20021199	<i>400°F for 2" lumps and above, 300°F for fines and dense baking loads</i>	3/8"	0.195	12"	#190 Solid Plate, #550 Bolt On, #R5 Rivet

Quality heat-resistant belt compounded to withstand elevated temperatures. Popular for cement and foundry applications. Will withstand occasional spikes up to 400°F. **Max operating temperature for fines and dense baking loads is 300°F.**



SPEC#	PART#	TEMP.	THICKNESS	WEIGHT (PIW)	MIN. PULLEY	RECOMMENDED LACING
2-PLY 220# 3/16 X 1/16 700° SUPER-HEAT						
41A	20021237	<i>700°F for 2" lumps and above, 500°F for fines and dense baking loads</i>	3/8"	0.195	12"	#190 Solid Plate, #550 Bolt On, #R5 Rivet

Premium belt for higher temperature requirements. Popular in cement and foundry applications. Hybrid cover compounds provide extended life and can take occasional spikes up to 700°F. **Max operating temperature for fines and dense baking loads is 500°F.**





SPEC#	PART#	TEMP.	THICKNESS	WEIGHT (PIW)	MIN. PULLEY	RECOMMENDED LACING
2-PLY 220# 3/16 X 1/16 350° SUPER OIL RESISTANT HOT ASPHALT						
42	20021030	0°F to 350°F	3/8"	0.195	12"	#190 Solid Plate, #550 Bolt On, #R5 Rivet

Excellent heat-and oil-resistant belt. Used in elevated oily temperature applications such as hot asphalt, machine oils and oil-treated coal. Special blended cover compounds provide maximum resistance to the deteriorating effects of oils and higher temperatures.



SPEC#	PART#	TEMP.	THICKNESS	WEIGHT (PIW)	MIN. PULLEY	RECOMMENDED LACING
3-PLY 330# 3/16 X 1/16 350° SUPER OIL RESISTANT HOT ASPHALT						
42A	20021093	0°F to 350°F	7/16"	0.215	18"	#190 Solid Plate, #550 Bolt On, #R5 Rivet

Excellent heat-and oil-resistant belt with higher tension strengths. Used in elevated oily temperature applications such as hot asphalt, oily grains, machine oils and oil-treated coal. Special blended cover compounds provide maximum resistance to the deteriorating effects of oils and higher temperatures.



SPEC#	PART#	TEMP.	THICKNESS	WEIGHT (PIW)	MIN. PULLEY	RECOMMENDED LACING
3-PLY 330# 1/4 X 1/16 400° MAXI-HEAT						
177	20026766	400°F for 2" lumps and above, 300°F for fines and dense baking loads	1/2"	0.232	18"	#190 Solid Plate, #550 Bolt On, #R5-1/2 Rivet

Quality heat-resistant belt compounded to withstand elevated temperatures. 1/4" top cover provides impact resistance and added carcass protection. Will withstand occasional spikes up to 400°F. **Max operating temperature for fines and dense baking loads is 300°F.**



SPEC#	PART#	TEMP.	THICKNESS	WEIGHT (PIW)	MIN. PULLEY	RECOMMENDED LACING
3-PLY 330# 1/4 X 1/16 700° SUPER-HEAT						
43A	20026790	700°F for 2" lumps and above, 500°F for fines and dense/ baking loads	1/2"	0.232	18"	#190 Solid Plate, #550 Bolt On, #R5 Rivet

Premium belt for higher temperature requirements. Popular in cement and foundry applications. 1/4" top cover provides impact resistance and added carcass protection. Will withstand spikes up to 700°F. **Max operating temperature for fines and dense baking loads is 500°F.**

MOLDED CHEVRON BELTING

For more information about DUROCLEAT™ belting see p. 60 in the Fabrication section.

SPEC#	PART#	TEMP.	THICKNESS	WEIGHT (PIW)	MIN. PULLEY	RECOMMENDED LACING
2-PLY 220# 1/8 X 1/16 DUROCLEAT™ GRADE 2						
57A	20029603	-25°F to 225°F	5/16"	0.210	12"	#190 Solid Plate, #375 Bolt On, #R5 Rivet

1/4" high x 3/8" wide x 6" overall width molded chevron cleats running the full width of the belt. Popular for incline applications for aggregate, road construction and recycling.

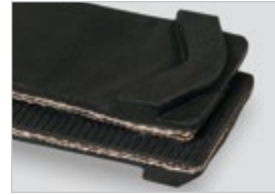

SPEC#	PART#	TEMP.	THICKNESS	WEIGHT (PIW)	MIN. PULLEY	RECOMMENDED LACING
2-PLY 220# 1/8 X 1/16 DUROCLEAT™ MODERATE OIL RESISTANCE						
58	20029601	0°F to 250°F	5/16"	0.210	12"	#190 Solid Plate, #375 Bolt On, #R5 Rivet

1/4" high x 3/8" wide x 6" overall width molded chevron cleats running the full width of the belt. Popular for incline applications for road construction, recycling, wood chips and grain handling.

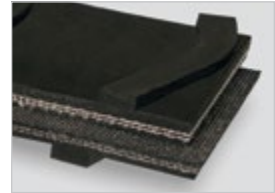

SPEC#	PART#	TEMP.	THICKNESS	WEIGHT (PIW)	MIN. PULLEY	RECOMMENDED LACING
3-PLY 330# 1/8 X 1/16 DUROCLEAT™ GRADE 2						
178	20029605	-25°F to 225°F	3/8"	0.260	18"	#190 Solid Plate, #550 Bolt On, #R5-1/2 Rivet

1/4" high x 3/8" wide x 6" overall width molded chevron cleats running the full width of the belt. Popular for incline applications for aggregate, road construction and recycling.



SPEC#	PART#	TEMP.	THICKNESS	WEIGHT (PIW)	MIN. PULLEY	RECOMMENDED LACING
3-PLY 330# 1/8 X 1/16 DUROCLEAT™ MODERATE OIL RESISTANCE						
59B	20029615	0°F to 250°F	3/8"	0.250	18"	#190 Solid Plate, #550 Bolt On, #R5-1/2 Rivet

1/4" high x 3/8" wide x 6" overall width molded chevron cleats running the full width of the belt. Popular for incline applications for road construction, recycling, wood chips and grain handling.



SPEC#	PART#	TEMP.	THICKNESS	WEIGHT (PIW)	MIN. PULLEY	RECOMMENDED LACING
2-PLY 220# 1/8 X BARE BACK DUROCLEAT™ MODERATE OIL RESISTANCE						
56B	20029602	0°F to 250°F	.283"	0.185	10"	#190 Solid Plate, #375 Bolt On, #R5 Rivet

1/4" high x 3/8" wide x 6" overall width molded chevron cleats running the full width of the belt. Designed to run on pan conveyors and metal beds. Very popular in recycling and wood products applications.

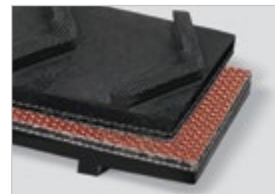

SPEC#	PART#	TEMP.	THICKNESS	WEIGHT (PIW)	MIN. PULLEY	RECOMMENDED LACING
3-PLY 330# 1/8 X BARE BACK DUROCLEAT™ MODERATE OIL RESISTANCE						
247	20029607	0°F to 250°F	.337"	0.225	12"	#190 Solid Plate, #550 Bolt On, #R5 Rivet

1/4" high x 3/8" wide x 6" overall width molded chevron cleats running the full width of the belt. Designed to run on pan conveyors and metal beds. Very popular in recycling and wood products applications.



MOLDED CHEVRON BELTING



SPEC#	PART#	TEMP.	THICKNESS	WEIGHT (PIW)	MIN. PULLEY	RECOMMENDED LACING
2-PLY 220# 5/8 X 16 DUROCHEV™ MOLDED CHEVRON CLEAT						
281	20029620	-40°F to 160°F	0.3307"	0.216	12"	#140 Solid Plate, #550 Bolt On, #R5 Rivet

Popular 5/8" high molded chevron cleats on 10" centers. Designed for rugged incline applications and popular for conveying rock, sand and gravel. Cleats recessed from belt edges allow for placement of skirting.



SPEC#	PART#	TEMP.	THICKNESS	WEIGHT (PIW)	MIN. PULLEY	RECOMMENDED LACING
2-PLY 220# CONTINUOUS CHEVRON TOP X BARE BACK						
103B	20029575	-40°F to 225°F	15/64"	0.130	12"	#2 Clipper®, #20 Alligator®, #125 Staple

Versatile profiled belt with V-pattern extending for full width of belt and providing excellent gripping characteristics. All-polyester, low-stretch carcass. Operates well in cold temperatures and is popular for handling sand, aggregate and agricultural products.

LACING

For time-saving, high-quality belt splicing, mechanical fasteners are the smart alternative to endless belts. The change-out or installation of fasteners can be an easy process, and there are a variety of fastener options available, including Flexco[®], Alligator[®], Clipper[®], and Super-Screw[®]. We're here to help you select the right option for your lightweight or heavy-duty belt application.

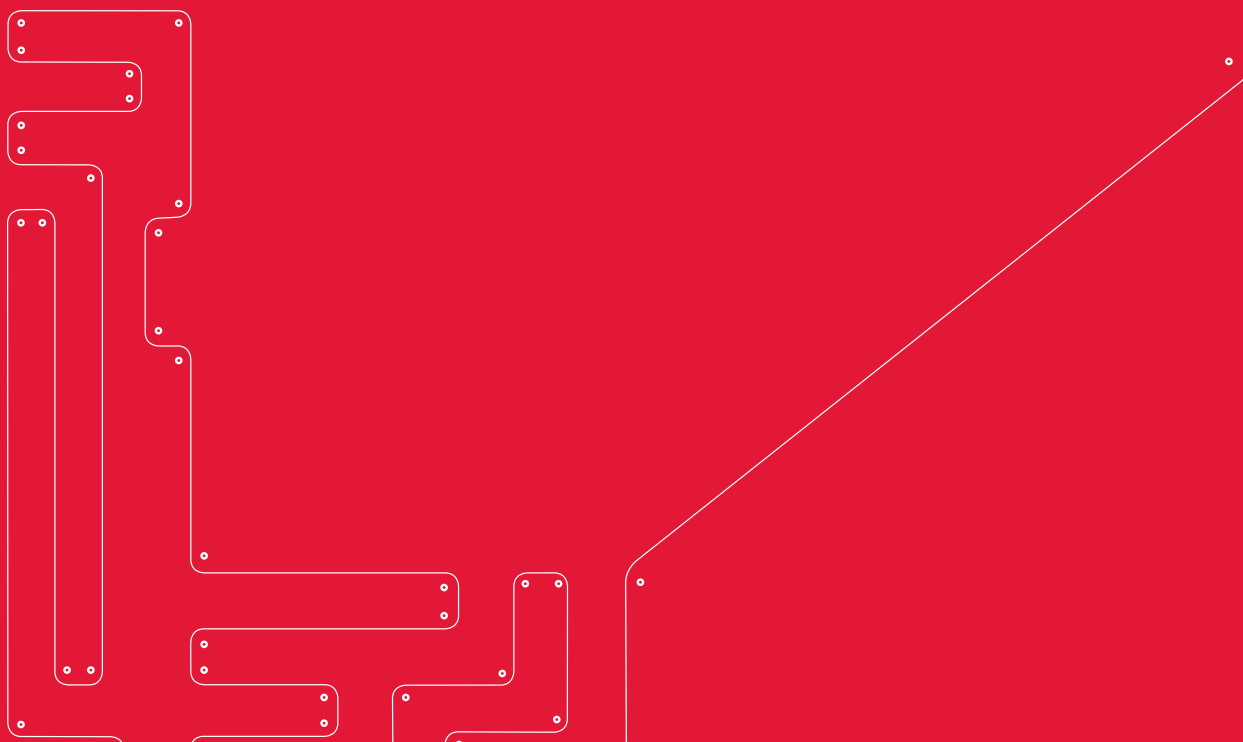

GOODYEAR
GOODYEARBELTING.COM

Call Toll Free: 1-866-711-4673
International: +1-727-342-5086

**We Ship
World Wide**

FLEXCO® FASTENER MATERIAL SELECTION GUIDE

FASTENER MATERIAL	CHARACTERISTICS										AVAILABILITY					
	ABRASION RESISTANCE	CHEMICAL RESISTANCE	RUST RESISTANCE	MAGNETIC	SPARK-FREE	CLIPPER® WIRE HOOK	ALLIGATOR® LACING	ALLIGATOR® STAPLE	PLASTIC SPIRAL LACE	ALLIGATOR® PLASTIC RIVET	ALLIGATOR® RIVET	FLEXCO® BOLT SOLID PLATE	FLEXCO® BOLT HINGED	FLEXCO® RIVET SOLID PLATE	FLEXCO® RIVET HINGED	
Steel	Good	Poor	Poor	Yes	No	•	•	•			•	•	•	•	•	
Galvanized Steel	Good	Poor	Good	Yes	No	•										
High Tensile Steel	Good to Excellent	Fair	Good	Yes	No	•										
400 Series Stainless Steel	Good	Fair to Good	Good	Yes	No	•		•						•		
300 Series Stainless Steel	Good	Good to Excellent	Excellent	Slightly	No	•	•	•			•	•	•	•	•	
Everdur	Poor	Poor	Poor	No	Yes						•	•	•			
MegAlloy®	Excellent	Poor	Poor	Yes	No			•			•	•	•	•	•	
RustAlloy®	Good	Good	Good	No	No										•	
Rubber Coated Steel	Good to Excellent	Poor	Poor	Yes	No						•					
Promal	Excellent	Good	Good	No	No						•					
Monel® 400	Fair	Excellent	Excellent	Slightly	No	•										
Inconel® 600	Fair	Excellent	Excellent even at high temps	No	No	•										
Phosphor Bronze	Good	Poor	Good	No	Yes	•										
Hastelloy C-22	Good	Excellent	Excellent	No	No	•										
Black Oxide	Good	Poor	Fair	Yes	No	•										
Non-Metallic	Poor	Fair	N/A	No	Yes				•	•						

FASTENERS



Clipper® Wire Hook



Alligator® Lacing



Alligator® Staple



Plastic Spiral Lace



Alligator® Plastic Rivet



Alligator® Rivet



Flexco® Bolt Solid Plate



Flexco® Bolt Hinged



Flexco® Rivet Solid Plate



Flexco® Rivet Hinged

GOODYEAR
GOODYEARBELTING.COM

Call Toll Free: 1-866-711-4673
International: +1-727-342-5086

**We Ship
World Wide**

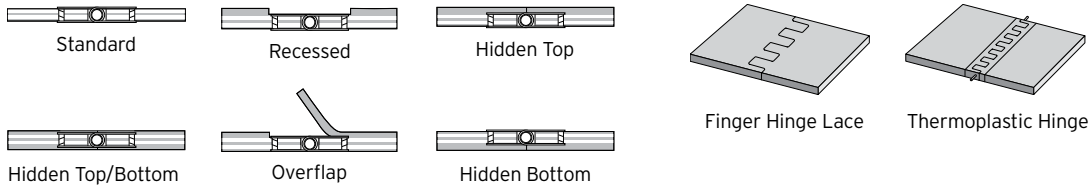
CUSTOM SPLICING OPTIONS**RECESSED LACE**

Mechanical splice area is recessed below the belt surface.

OVERFLAP

Mechanical lacing is installed below the belt surface and the top cover is separated from the belt carcass creating a flap over. The cover flap can be glued down after installation.

HIDDEN LACE

Mechanical fasteners are installed below the belt cover to prevent the lace from contacting the product.

FINGER HINGE LACE

Finger hinge lace is equipped with flexible, hinged plastic lacing, creating an easy, quick repair alternative to endless belts. FHL requires the belt be made of PVC or polyurethane, have a thickness of .08" to .263", have a minimum belt length of 55", and a maximum belt width of 40".

THERMOPLASTIC HINGE

Thermoplastic hinge lace is made with the same homogeneous material as your belt. This lace is welded to the belt and connected with a metal or nylon pin. Nylon pins should be used when metal detectors are required. (This option is available for Volta products only.)

ENDLESS NON-MECHANICAL SPLICING SOLUTIONS

Endless splicing methods eliminate the need for hardware fasteners. This fabrication technique is excellent for food processing and applications where products need to be handled with greater care.

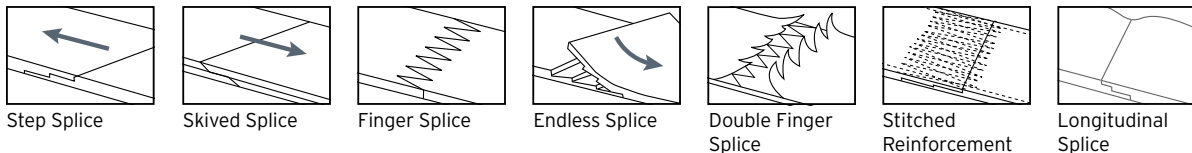
**STEP SPLICE BELT**

For belts with multiple plies. Plies are separated and "stepped" to interlock with one another at the splice point. Performed by experts in our fabrication facility for quality assurance and appropriate curing time.

SKIVED SPLICE

A precision grinding technique is used to achieve uniform thickness at the splice point for a variety of applications.

FINGER SPLICE

For thermoplastic, urethane and PVC belts. A very durable splice that maintains a smooth belt surface throughout the splice area. Multiple finger patterns are available to meet a variety of applications and system pulley sizes.

site. (Cement bonding kits with instructions are available.)

DOUBLE FINGER SPLICE

Unlike a standard finger splice, fingers are cut from multiple plies, staggered, then fused together by heat and pressure to create a stronger, more flexible splice.

STITCHED REINFORCEMENT

Certain applications put unusual wear on splices and edges. These areas can be strengthened with stitching.

LONGITUDINAL SPLICING

Very wide belts are created by longitudinally splicing two or more belts of narrower dimension. Plies are expertly stepped and bonded in our fabrication facilities to create

LIGHTWEIGHT

LIGHTWEIGHT WIRE HOOK SYSTEM

Please note this chart represents common hook sizes. Additional sizes are available or can be custom made for specific application requirements.

CLIPPER® FASTENER AND PIN SIZE SELECTION CHART														
MINIMUM PULLEY DIAMETER	WIRE DIAMETER		BELT THICKNESS											
			Up to 3/64" .047	1/16" .063"	3/32" .093"	1/8" .125"	5/32" .156"	3/16" .188"	7/32" .219"	1/4" .250"	9/32" .281"	5/16" .313"	11/32" .344"	25/64" .390"
	IN	MM	1.2 mm	1.6 mm	2.4 mm	3.2 mm	4.0 mm	4.8 mm	5.6 mm	6.4 mm	7.1 mm	7.9 mm	9.0 mm	10.0 mm
15/16" 24 mm	.025	0.6	25SP*											
	.025	0.6	25											
	.036 x .027	0.9 x 0.7	UCM36SL XSP											
	.036 x .027	0.9 x 0.7		UCM36SL SP										
2" 51 mm	.036 x .027	0.9 x 0.7	UCM36 XSP											
	.036 x .027	0.9 x 0.7		UCM36 SP*										
	.036 x .027	0.9 x 0.7		36 SP*										
	.040	1.0		1 XSP*										
	.040	1.0		UX-1 SP*										
	.036 x .027	0.9 x 0.7			UCM36*									
	.036 x .027	0.9 x 0.7			36*									
	.040	1.0			1 XSP*									
	.036 x .027	0.9 x 0.7				UCM36 LP*								
	.040	1.0				1 *								
	.040	1.0				UX-1*								
	.054	1.4				U2 SP								
	.054	1.4				2SP								
	3" 76 mm	.054	1.4					2						
.054		1.4					U2							
.054		1.4						3						
4" 102 mm	.054	1.4						U3						
	.054	1.4							4					
5" 127 mm	.054	1.4							U4					
	.054	1.4								4 1/2				
6" 152 mm	.054	1.4									5			
	.054	1.4									U5			
7" 175 mm	.054	1.4										6		
	.054	1.4										U6		
7" 175 mm	.054	1.4											7	
	.054	1.4											U7	

*Long Leg configuration is available. Allow for 1" (25 mm) larger minimum pulley diameter.

FASTENER RATINGS		HOOK ABBREVIATIONS		UNIBAR®
HOOK SERIES	OPERATING TENSION RANGE	XSP	Extra Short Point	
25 Series	Up to 60 PIW/10.2 kN/m	SP	Short Point	
36 Series	Up to 75 PIW/12.7 kN/m	LP	Long Point	
1(40) Series	Up to 75 PIW/12.7 kN/m	SL	Short Leg	
				CARDED



Call Toll Free: 1-866-711-4673
International: +1-727-342-5086



SUPER-SCREW® FASTENERS

Super-Screw® fasteners have the strength and dependability of a vulcanized splice without the costly downtime needed to fabricate an endless belt. With the ability to be installed on any conveyor belt, even in challenging access situations, this fastener is quick and easy to install.

Constructed of multi-ply rubber, Super-Screw® fasteners attach to the belt with special, self-tapping screws. These screws allow the carcass threads to spread without cutting completely through them. This fastener can be fitted to your belt with one, two, or three rows of screws.

ADVANTAGES OF USING SUPER-SCREW® FASTENERS INCLUDE:

- ▶ Quick installation
- ▶ Installs in all weather conditions
- ▶ Cost effective – no need for expensive equipment
- ▶ Requires no drilling preparation or templates
- ▶ Suitable for belt up to 400°F (200°C)
- ▶ Compatible with conveyor scrapers
- ▶ Prevents material loss
- ▶ Abrasion- and cut-resistant
- ▶ Contains high-tensile strength and elasticity
- ▶ Available on a roll or in cut lengths
- ▶ A variety of compounds available



SUPER-SCREW® GENERAL DATA											
SUPER-SCREW® TYPES	35	63	65	80	85	100	105	125	127	180	200
Belt Thickness	5/32" 3.97 mm	5/32 to 1/2" 3.97 to 12.7 mm	5/32 to 1/2" 3.97 to 12.7 mm	5/32 to 19/32" 3.97 to 15.08 mm	5/32 to 19/32" 3.97 to 15.08 mm	5/32 to 19/32" 3.97 to 15.08 mm	5/32 to 14/32" 3.97 to 11.11 mm	9/32 to 13/16" 7.14 to 20.64 mm	9/32 to 13/16" 7.14 to 20.64 mm	9/32 to 13/16" 7.14 to 20.64 mm	9/32 to 3/4" 7.14 to 19.05 mm
Max. Belt Strength (N/Mm)	315	630	630	800	800	1,000	1,000	1,250	1,500	1,800	2,000
Max. Belt Tension (PIW)	200#	360#	360#	460#	460#	570#	570#	710#	710#	1,000#	1,150#
Min. Pulley Ø	6" 152.4 mm	8" 203.2 mm	8" 203.2 mm	10" 254 mm	10" 254 mm	12" 304.8 mm	12" 304.8 mm	12" 304.8 mm	12" 304.8 mm	16" 406.4 mm	20" 508 mm
Top Thickness	5/32" 3.97 mm	3/16" 4.76 mm	15/64" 5.95 mm	15/64" 5.95 mm	9/32" 7.14 mm	9/32" 7.14 mm	11/32" 8.73 mm	9/32" 7.14 mm	11/32" 8.73 mm	9/32" 7.14 mm	11/32" 8.73 mm
Bottom Thickness	5/32" 3.97 mm	11/64" 4.37 mm	11/64" 4.37 mm	7/32" 5.56 mm	7/32" 5.56 mm	7/32" 5.56 mm	7/32" 5.56 mm	15/64" 5.95 mm	15/64" 5.95 mm	15/64" 5.95 mm	15/64" 5.95 mm

HEAVY-DUTY



Call Toll Free: 1-866-711-4673
International: + 1-727-342-5086



**READY TO INSTALL**

Order Super-Screw® fasteners ready to install and get the length your customer needs, including all the accessories necessary to install them yourself.

- ▶ Spacers come pre-installed
- ▶ Top and bottom match
- ▶ Delivered with screws and PZ bit

*Maximum assembled length is 10 ft (3.048 m)

**IN A ROLL**

Super-Screw® fasteners are also available in lengths up to 82 ft (25 m). These rolls are delivered in two separate coils (top and bottom sections). To complete your order consider adding:

- ▶ Spacers
- ▶ Bucket of screws
- ▶ PZ bit

**AVAILABLE COMPOUNDS**

Super-Screw® fasteners work in a variety of rubber applications because they have the following compound characteristics:

- ▶ Abrasion-resistant
- ▶ Heat-resistant
- ▶ Low temperatures
- ▶ Oil-resistant
- ▶ Fire retardant and anti-static
- ▶ White FDA/USDA cover with stainless steel inserts and screws

FABRICATION

We are a custom fabricator – you tell us what you need and we will create it for you. Our belt technicians fabricate essentially any belt configuration to meet a range of applications, producing some of the industry's most advanced custom-cleated belts.

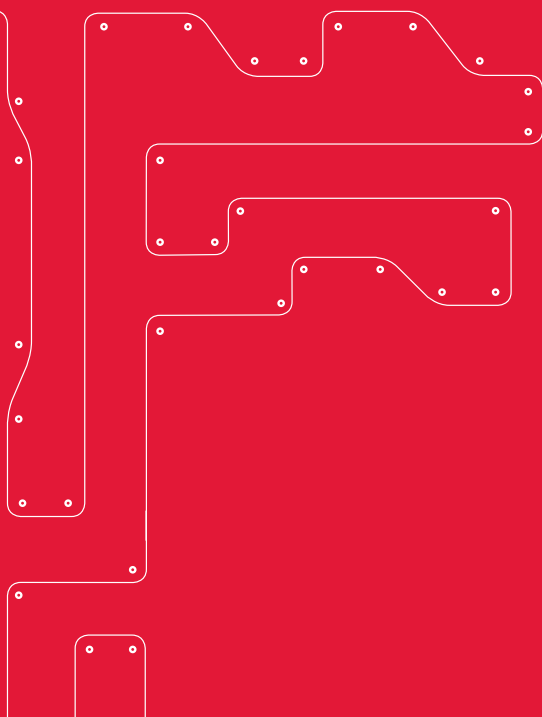

GOODYEAR
GOODYEARBELTING.COM

Call Toll Free: 1-866-711-4673
International: +1-727-342-5086

**We Ship
World Wide**

LIGHTWEIGHT & HEAVY-DUTY

V-GUIDES

V-guides are used to help belts track properly on conveyors. Used on the bottom of a belt they serve as a guide, but can also be attached to the top of the belt and used as a vanner edge. A broad range of V-guide profiles are available. Single center guides are popular for narrow belts. Wider belts many times use a V-guide on the bottom of each belt edge and are popular for short and reversing conveyors.

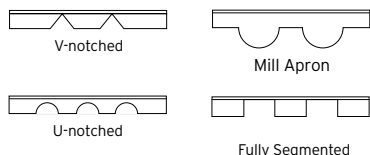
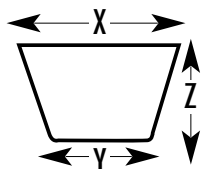

V-guides can also be HF Welded. See p. 60

V-GUIDE GENERAL SPECS

TYPE	X	Y	Z		
K-6		6 mm	4.5 mm		3.5 mm
Modified K-8		6 mm	4.5 mm		3.175 mm
K-8		8 mm	4.5 mm		4.5 mm
K-10/O	3/8"	10 mm	1/4"	6 mm	1/4" 6 mm
Modified A	7/16"	11.112 mm	3/8"	9 mm	1/4" 6 mm
K-13/A	1/2"	13 mm	5/16"	7 mm	5/16" 7.5 mm
K-17/B	5/8"	17 mm	3/8"	9 mm	3/8" 11 mm
K-22/C	7/8"	22 mm	9/16"	12 mm	1/2" 11 mm
D	1-1/4"	32 mm	3/4"	19 mm	3/4" 19 mm
E	1-3/8"	35 mm	1"	25.4 mm	3/4" 19 mm
Mill Apron	3-1/8"	79 mm	2-1/4"	57 mm	7/8" 22 mm

LIGHTWEIGHT & HEAVY-DUTY

VANNER / FLANGED EDGES

The primary purpose of vanner edges is to prevent material from spilling off the outside edges of the conveyor belt. Flanges are offered in rubber, which are hot vulcanized to the top cover, or in PVC, which are "hot welded" to the top surface.

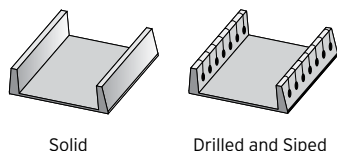

VANNER EDGE

Cleat Height	1/2"	1"	1-1/2"	2"	2-1/2"	3"
Solid	9"	10"	16"	18"	20"	24"
Drilled/Siped	6"	6"	8"	12"	12"	16"

FLANGED DRILLED AND SIPED

When additional flexibility is needed to flex around a pulley, vanner edges can be drilled and siped.

- ▶ Vanner edges are popular in "weigh feeder" applications, where product is weighed or metered as it feeds another system.
- ▶ Vanner edges are furnished in solid form, or siped/slit from the top to the bottom of the vanner, where a hole is drilled to help with flexibility and to prevent the slit section from splitting or tearing.
- ▶ This process is referred to as drilling and siping, which improves the flexibility of the vanner and allows it to operate on smaller pulley diameters. For rubber compounds, flanges come in a standard hardness of 60 durometer, but they are available in a softer 40 durometer compound for wrapping smaller pulleys.

CLEATS

Cleats are used to convey materials up an incline and prevent product rollback, as well as to create separation between the products or materials that are being conveyed. Other names for cleats include flights, lugs and profiles. We offer a wide variety of cleat styles and patterns to fit every application need.

**LIGHTWEIGHT
& HEAVY-DUTY**

**CLEAT
MODIFICATION
OPTIONS**

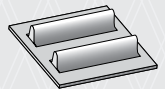

Indented

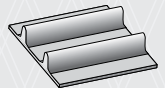

Full-width

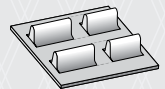

Cut-out

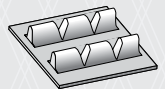

Notched

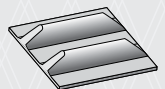

Tapered

MINIMUM PULLEYS						
TYPE	RUBBER SOLID	RUBBER NOTCHED/SIPED	PVC-RV SOLID	PVC-RV NOTCHED	URETHANE SOLID	URETHANE NOTCHED
V-GUIDE (USED AS CLEAT)						
K6			1-3/4"	1-1/4"		
K8			2"	1-1/2"	2"	1-1/2"
Modified K8					1-1/2"	
O Section	3"	2-1/2"	2-1/2"	2"	4"	3"
Modified A			2-1/2"	2"		
A Section	3"	2-1/2"	3"	2-1/2"	5"	4"
B Section	5"	3"	5"	3"	6"	5"
C Section	6"	4"	6"	4"	9"	7"
D Section			8"	6"		
FLANGE (USED AS CLEAT)						
1" High	10"	7"		8"		
1-1/2" High	18"	14"		14"		
2" High	18"	14"		14"		
CLEAT						
O Lug	3"		2-1/2"		2-1/2"	
A Lug	3"		2-1/2"		3"	
B Lug	3-1/2"		3"		3-1/2"	
C Lug	4"		4"		4"	
1/4" x 1/4" Lug	3"		2-1/2"		2-1/2"	
1/2" x 1/2" Lug	3-1/2"		3"			
1/2" Tee	3"		3"		3"	
1" Tee	4"		3"		3"	
1" Scoop	4"		4"			
1" (25 mm) Thin Line					3.5"	
1-1/4" (30 mm) Thin Line					3.5"	
1-1/2" Tee	5"		4"		4"	
1-1/2" Scoop	5"		5"			
1-1/2" Urethane HD					6"	
1-1/2" (40 mm) Thin Line						
2" PVC HD			5.5"			
2" Tee	6"		5"		5"	
2" (50 mm) Thin Line					3.5"	
2" Urethane HD					8"	
2" Scoop	6"		6"			
2-1/2" Tee	8"		6"			
2-1/2" Scoop	8"		7"			
3" PVC HD			6.5"			
3" Tee	10"		8"			
3" Scoop	10"		9"			
4" Tee	12"		10"			
5" Tee	18"					

LIGHTWEIGHT

LIGHTWEIGHT HF WELDED CLEATS

High frequency (HF) welded profiles combine advanced technological features to optimize productivity, and provide quality custom products to meet your customers' unique application needs. The HF welding process creates a strong, consistent bond between two polymers. This strong bond helps ensure food safety while offering protection from bacteria contamination. It's also ideal for small parts, metals and plastics. HF welded features include:

NOTE:

HF welding can be done on any thermoplastic belt.

- ▶ Stronger bond than traditional welding methods
- ▶ Custom profiles available for specialty applications
- ▶ Narrow-base widths to wrap smaller pulleys
- ▶ Precision placement of cleats
- ▶ Longer service life
- ▶ Easy cleaning
- ▶ Thin line and footless cleats available
- ▶ A variety of sizes and thicknesses available

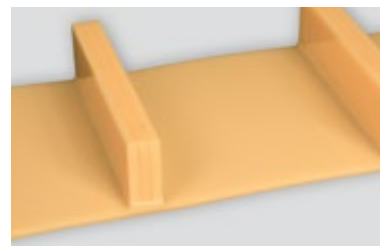
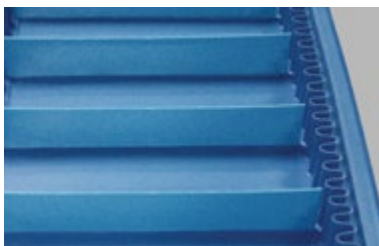

HEAVY-DUTY

HEAVY-DUTY PROFILES & CLEATS

Apache | Trico Industrial Division hot vulcanizes a variety of rubber cleat styles for incline applications. We can customize the cleat configuration to meet your individual application needs.

HOT VULCANIZED RUBBER PROFILES

HEAVY-DUTY PROFILES INCLUDE:

- All black rubber
- MOR
- Heat-resistant
- SCOFR
- MSHA

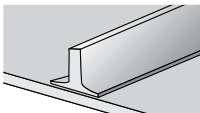

STANDARD CLEATS (T-CLEAT)

Cleat Height	1"	1-1/2"	2"	2-1/2"	3"			
Min. Pulley Dia.	4"	5"	6"	8"	8"			

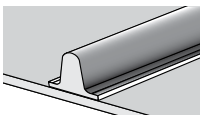

HEAVY-DUTY CLEATS (T-CLEAT)

Cleat Height	1"	1-1/2"	2"	3"	4"	5"	6"
Min. Pulley Dia.	5"	8"	8"	8"	12"	18"	18"

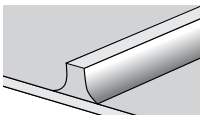

SQUARE CLEATS

Cleat Height	3/8" x 3/8"	1/2" x 1/2"	3/4" x 3/4"	1" x 1"		
Min. Pulley Dia.	3"	4"	8"	10"		

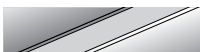

SCOOP CLEAT (C STYLE)

CUSTOM CHEVRON CLEATS

Below are examples of some of our most popular designs – we have over 150 patterns available but can customize them to your specific needs. Heights normally range from 1/4" to 1-1/2" to prevent rollback. Normal incline angles range from 15-35 degrees depending on material conveyed and surcharge angle. Chevron cleats are also used on flat idlers as well as metal beds or pan conveyors.

RULE OF THUMB:

Cleat height should be approximately 1/2 to 2/3 of the material size for uniform bulk material (such as sand and grain)

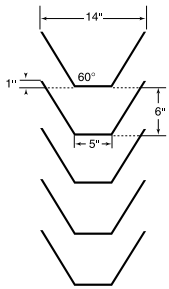

TEMPLATE #8
1/2" x 1/2" Square U-shaped Cleats

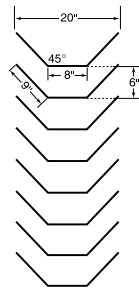

TEMPLATE #8A
1/2" x 1/2" Square U-shaped Cleats

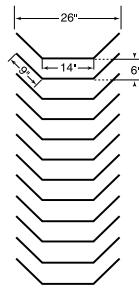

TEMPLATE #8B
1/2" x 1/2" Square U-shaped Cleats

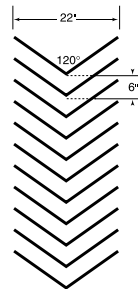

TEMPLATE #32
3/8" x 3/8" Closed Chevrons to 28" Wide

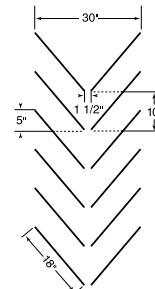

TEMPLATE #40
1/2" x 1/2" Square Chevron

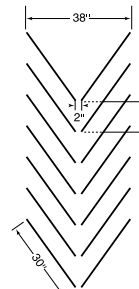

TEMPLATE #6
1/2" x 1/2" Square Chevron

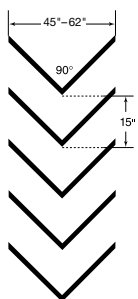

TEMPLATE #34
1" Height x 2" Width 45" to 62"



TEMPLATE #35
1/2" x 1/2" Square 30" to 54"

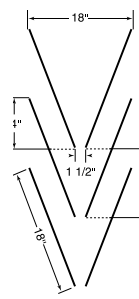

TEMPLATE #38
1/2" x 1/2" Square Chevron

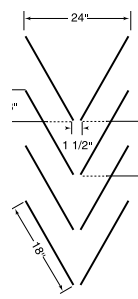

TEMPLATE #39
1/2" x 1/2" Square Chevron

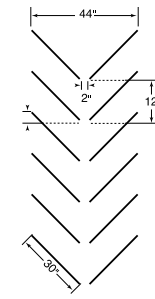

TEMPLATE #36
1/2" x 1/2" Rect. Cleats for 44" or Wider Belts

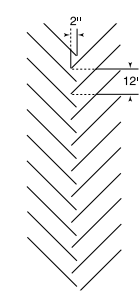

TEMPLATE #37
1/2" x 1/2" Square Herringbone 12" to 44"

STEEL CLIMBERS™ CLEAT PATTERNS

Apache | Trico Industrial Division's Steel Climber™ hot vulcanized rubber cleats are specifically designed for the larger material and steeper incline angles used in troughing systems. This versatile and durable cleat pattern comes in four (4) widths: 13-27". Cleat spacing is 10" to ensure smooth running on return idlers.

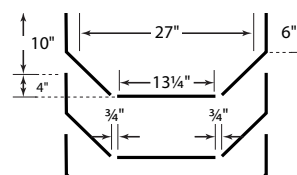
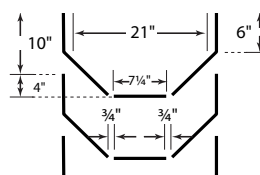
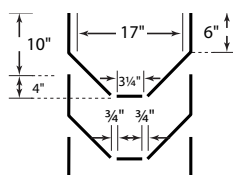
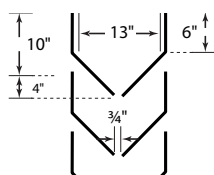

Apache has a variety of Durocleat™ belt specs listed on p. 49.

DUROCLEAT™

Molded chevron cleated belt is available in six different specifications, with cleats in a uniform pattern running across the width of the belt.

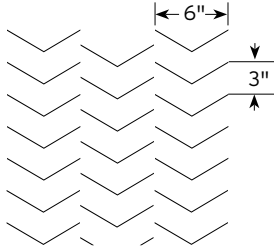

- ▶ Cleat dimensions are 1/4" high x 3/8" wide x 6" overall width
- ▶ This versatile V-cleat belt is available with rubber bottom covers, as well as bare back constructions for operating on metal beds
- ▶ Compounds include standard grade 2 and MOR for oily conditions
- ▶ Durocleat is widely used for conveying grain, woodchips, sand, aggregate and refuse in recycling facilities

See p. 50, spec #281.

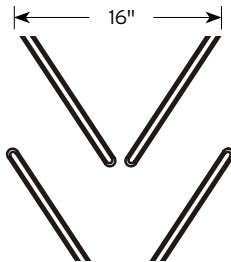

DUROCHEV™

Durochev belts have a 5/8" high molded chevron cleats on 10" centers. These belts are designed for rugged incline applications and popular for conveying rock, sand and gravel. The molded cleats are recessed from belt edges to allow for placement of skirting.

ROCK CHUCKER™

These fully molded chevron cleated belts are designed for "placing" product in confined/hard-to-reach areas. This versatile 2-ply belt is an excellent choice for throwing rock, sand, mulch, dirt and other bulk materials. Apache | Trico Industrial Division's Rock Chucker belts are vulcanized endless to withstand the stress of high speeds and small pulley diameters. Belt width is 14 inches.

Popular applications include:

- ▶ Basement/foundation jobs
- ▶ Residential and commercial construction
- ▶ Landscaping maintenance and construction
- ▶ Driveway, sidewalk and curb construction
- ▶ Trenching for public utilities

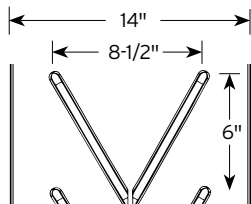

GOODYEAR
GOODYEARBELTING.COM

Call Toll Free: 1-866-711-4673
International: +1-727-342-5086

We Ship
World Wide

- ▶ High-strength rubber compounds
- ▶ Rugged wide cleat base and tapered ends eliminate cleat separation from belt
- ▶ Will withstand the rigors of high speeds and small pulley diameters
- ▶ 1" high cleats for more carrying capacity and better leveling of material on carrying side
- ▶ Smoother, quieter return and better tracking thanks to the center stabilizer bar on the V-cleat construction
- ▶ Mechanical fasteners are also available

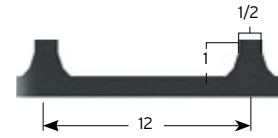

Cleat Pattern Cross Section

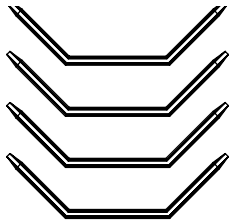

Molded U-cleat
Road-Away™ Milling Belt

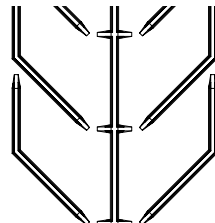

V-cleat Road-Away™
Milling Belt

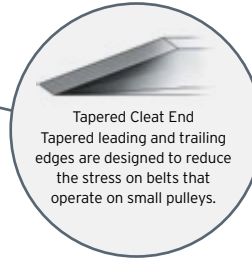

GOODYEAR
GOODYEARBELTING.COM

Call Toll Free: 1-866-711-4673
International: +1-727-342-5086

**We Ship
World Wide**



MOLDED U-CLEAT ROAD-AWAY™ MILLING BELT PATTERNS

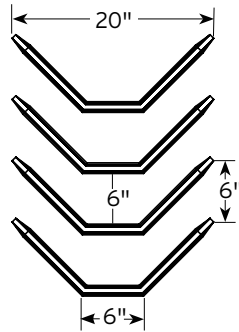

20" cleat pattern
24" minimum belt width

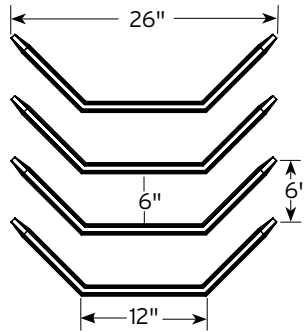

26" cleat pattern
36" minimum belt width

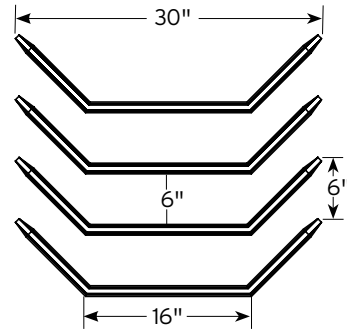

30" cleat pattern
42" minimum belt width

VULCANIZED CUSTOM CLEATED BELT PATTERNS FOR MILLING AND OTHER APPLICATIONS

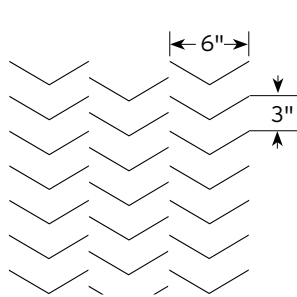

Durocleat™ Molded Chevron
Cleats: 1/4" high x 3/8" wide

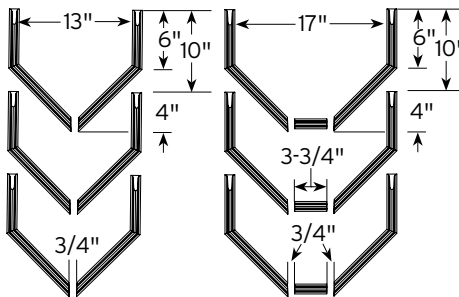

Steep Angle Chevrons
Cleats: 1-1/2" high x 3/4" wide

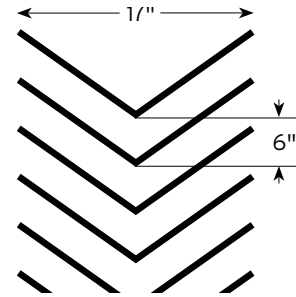

Closed Chevrons
Cleats: 3/8" high x 3/8" wide

MOLDED V-CLEAT ROAD-AWAY™ MILLING BELT PATTERNS

12" Cleat centers - Metric widths available

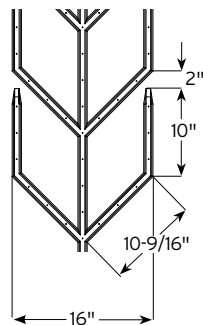

24" maximum belt width

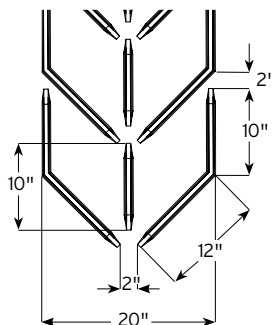

30" minimum belt width

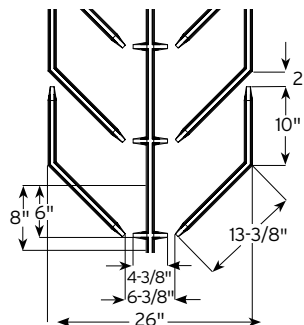

36" minimum belt width

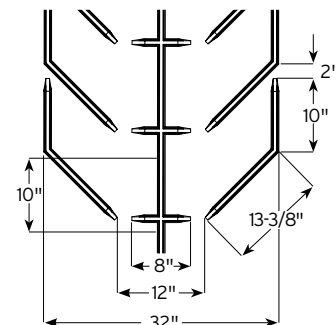

42" minimum belt width

- ▶ We use a special angle beveling technique in the top cover that eliminates the possibility of cracks developing in the splice, thus eliminating product contamination in the splice area
- ▶ We can splice almost all impression top belting without removing the top covers (such as Durocleat™, diamond top, Z-top, roughtop, pebbletop)
- ▶ Apache can do multiple longitudinal splices to make a single belt up to 14-16 feet wide
- ▶ These extra wide belts can be made endless prior to shipping or have ends prepared for splicing in the field
- ▶ V-guides and other profiles can be added as required
- ▶ Any carcass type: solid woven polyester, non-woven, needled, standard plies
- ▶ Cover surfaces: smooth, rubber, PVC, urethane, fabric friction, light impression



GOODYEAR
GOODYEARBELTING.COM

Call Toll Free: 1-866-711-4673
International: +1-727-342-5086

**We Ship
World Wide**

- ▶ Our lightweight Durowall is offered in a variety of thermoplastic and conventional rubber compounds for belting, cleats, and sidewalls
- ▶ These belts are suitable for applications requiring FDA/USDA/3A certifications, oil resistance, and anti-static properties



LIGHTWEIGHT DUROWALL CLEAT OPTIONS

We have the cleat profiles to fit your application:

- ▶ T-cleat for most incline needs
- ▶ Scoop cleats for steeper angles
- ▶ Thin line cleats for smaller pulley diameters and lower tonnages

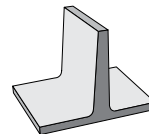

T-Cleat

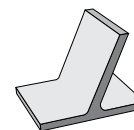

Scoop Cleat

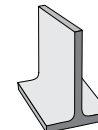

Thin-Line Cleat

LIGHTWEIGHT CORRUGATED SIDEWALLS

Polyurethane corrugated sidewalls are available when food-grade requirements apply and provide consistent dependability. Black rubber sidewalls are used when more durability is needed or in applications that require a more robust construction.

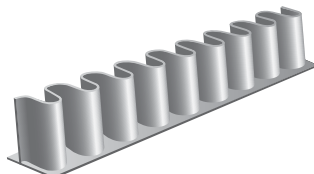

POLYURETHANE SIDEWALL

HEIGHT		MIN. PULLEY DIA.	
1-3/16"	30 mm	2-3/8"	60 mm
1-1/2"	40 mm	3-1/8"	80 mm
2"	50 mm	3-1/2"	90 mm
2-3/8"	60 mm	4-3/8"	110 mm
3-1/8"	80 mm	5-1/2"	140 mm

LIGHTWEIGHT RUBBER SIDEWALL

HEIGHT	BASE WIDTH		MIN. PULLEY DIA.		
1"	25 mm	1-1/2"	40 mm	2"	50 mm
1-1/2"	40 mm	1-1/2"	40 mm	3"	75 mm
2"	50 mm	1-1/2"	40 mm	3"	75 mm



Various cleat sizes and styles are available. Sidewalls and cleats are also available in various colors.

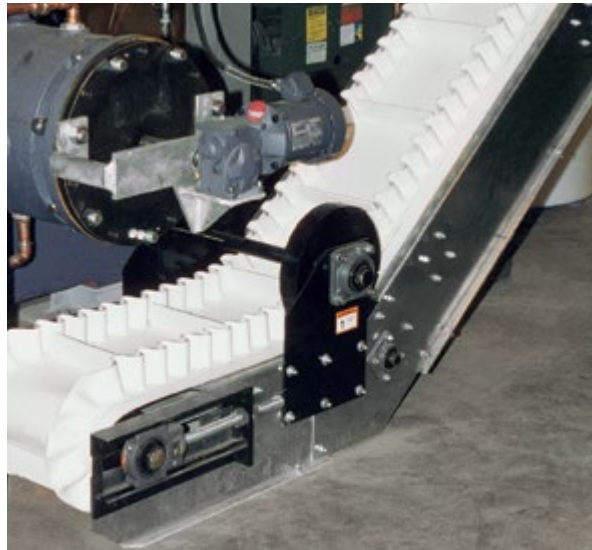

Durowall lightweight belts are popular for operating in confined areas, particularly when products need to be quickly elevated



Belt components are attached to the base belts by hot air and high frequency (HF) welding or hot bonded for rubber components. The base belts are engineered to provide the features needed for maximum performance – transverse stiffness prevents bowing at conveyor transition/change-of-direction points, while also remaining flexible in the longitudinal direction to negotiate small pulleys.

POPULAR APPLICATIONS INCLUDE:

- Bakeries
- Cereals
- Confection
- Wood products
- Recycling
- Glass
- Dairies
- Warehousing
- Injection molding
- Metal parts
- Plastics
- Light manufacturing

DUROWALL CROSS RIGID LIGHTWEIGHT BELTING										
STYLE	TOTAL PLYS	TENSION PLYS	PIW RATING	CROSS-RIGID PLYS	COVERS	PIW WEIGHT	OVERALL GAUGE (OAG)	MINIMUM PULLEY	COLOR	COMPOUND
AXB 150 (Anti-static)	3	3	150	3	1/32 x Bare	0.100	0.156	6"	White	RMV
AXB 150 (Anti-static)	3	3	150	3	1/32 x Bare	0.083	0.18	3"	Black	RMV
AXB 160	3	2	160	1	1/16 x Bare MOR	0.140	0.25	4"	Black	Rubber
AXB 200 (Anti-static)	4	4	200	4	1/32 x Bare	0.140	0.22	8"	White	RMV
AXB 200	4	4	150	4	1/32 x Bare	0.140	0.22	6"	Black	RMV

MOR = Moderate Oil Resistance

RMV = Rubber Modified Vinyl



Call Toll Free: 1-866-711-4673
International: + 1-727-342-5086



CROSS-RIGID BASE BELTING

- ▶ Cross-rigid base belting helps deliver material in an efficient, cost-effective manner for applications that may challenge standard belts. That means a leaner, more efficient system without worry of belt failure or downtime.
- ▶ Our Durowall cross-rigid belting is specifically designed to provide lateral stiffness and eliminate belt bowing and cupping at directional change points on the conveyor. It also helps reduce belt sag on the return run.
- ▶ Although the belt is rigid in the transverse direction, it remains flexible in the longitudinal direction. This unique design allows the belt to operate on standard pulleys and not interfere with the conveyor structure.

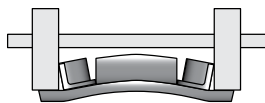

Conventional Belting
Carrying Side

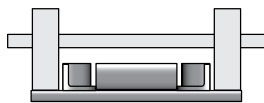

Cross Rigid Belting
Carrying Side



Conventional Belting
Return



Cross Rigid Belting
Return

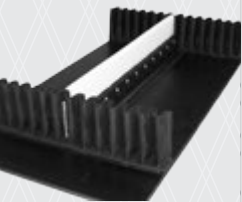

Heavy-Duty
Durowall™
Worksheet p. 94

DUROWALL™ CROSS-RIGID HEAVY-DUTY BELT

STYLE	TOTAL PLYS	TENSION PLYS	PIW RATING	CROSS-RIGID PLYS	COVERS	PIW WEIGHT	OVERALL GAUGE (OAG)	MINIMUM PULLEY	COLOR	COMPOUND
AXB 160	3	2	150	1	1/16" x BARE MOR	.14	.25	4"	Black	RUBBER
AXB 220	4	2	220	2	1/8" x 1/16"*	.295	.465	14"	Black	RUBBER
AXB 225	3	1	225	2	1/8" x BARE MOR	.160	.25	8"	Black	RUBBER
AXB 330	5	3	330	2	1/8" x 1/16"*	.325	.510	16"	Black	RUBBER
AXB 440	6	4	440	2	3/16" x 1/16"*	.360	.605	24"	Black	RUBBER
AXB 550	7	5	550	2	3/16" x 1/16"*	.400	.700	30"	Black	RUBBER

* Available Rubber Compounds: Black Standard, Black-Oil-Resistant, Black Static-Conductive, Black (MSHA) and Black Heat-Resistant (400°F)

MOR = Moderate
Oil Resistance

GOODYEAR
GOODYEARBELTING.COM

Call Toll Free: 1-866-711-4673
International: +1-727-342-5086

**We Ship
World Wide**

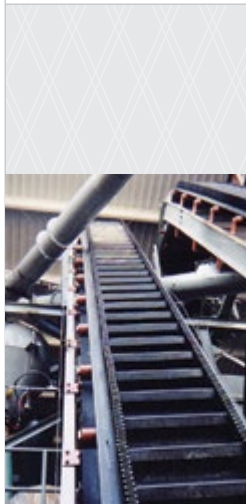

HEAVY-DUTY DUROWALL™ CLEAT OPTIONS

We designed our Durowall™ belting with a variety of cleating styles and compounds to allow for maximum operational efficiency based on the required capacity and angle of inclination. Belting is available with both single- and two-piece combination cleats. Many of the larger cleats we provide are fabric reinforced to withstand punishment at loading points (two-piece cleat compounds include rubber, polyurethane, high-temp polyurethane and UHMW). Taller cleats are normally bolted to the sidewalls for additional strength and flexibility.

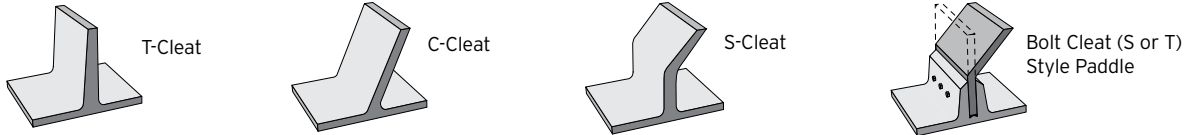

CORRUGATED SIDEWALLS

Durowall corrugated sidewalls (available in heights from 1" to 12") are manufactured in a variety of compounds to best suit your application needs. All of our corrugated sidewalls have high tensile strength properties for added flexibility and toughness in order to withstand cutting, tearing and abrasion. We also offer fabric-reinforced sidewalls for products greater than 6" tall to provide additional strength and tear resistance.

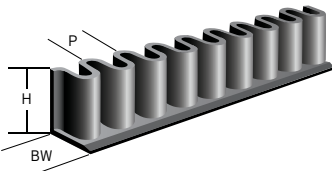
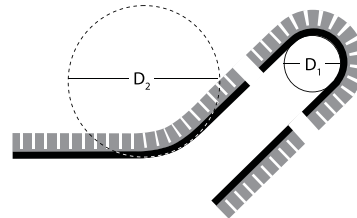

DUROWALL™ CORRUGATED SIDEWALLS						
Add 25% to min. pulley diameter for other than Black Standard						
HEIGHT (H)	BASE WIDTH (BW)	PITCH (P)	WEIGHT (Per Foot/Lbs.)	CLEAT HEIGHT (Recommended)	D1 (Min. Pulley Dia.)	D2 (Min. Deflection Dia.)
1"	1-1/2"	1"	.30	-	2"	8"
1-1/2"	1-1/2"	1"	45	1"	3"	8"
2"	1-1/2"	1"	.60	1-1/2"	3"	8"

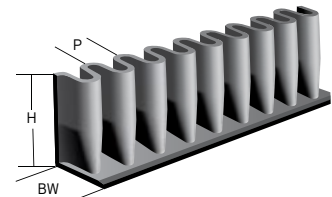

DUROWALL™ CORRUGATED SIDEWALLS						
Add 25% to min. pulley diameter for other than Black Standard						
HEIGHT (H)	BASE WIDTH (BW)	PITCH (P)	WEIGHT (Per Foot/Lbs.)	CLEAT HEIGHT (Recommended)	D1 (Min. Pulley Dia.)	D2 (Min. Deflection Dia.)
2"	2"	1-5/8"	.80	1-1/2"	6"	10"
2-1/2"	2"	1-5/8"	.95	2"	6"	12"
3"	2"	1-5/8"	1.10	2-1/2"	8"	16"
4"	2"	1-5/8"	1.40	3-1/2"	10"	18"
5"	2"	1-5/8"	1.75	4-1/2"	12"	20"
6"	2"	1-5/8"	2.20	5-1/2"	14"	24"

Any height available between 2" high and 6" high

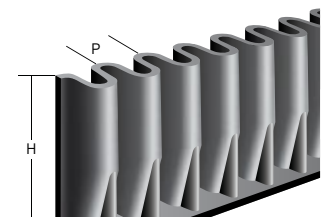

DUROWALL™ FABRIC REINFORCED CORRUGATED SIDEWALLS						
Add 25% to min. pulley diameter for other than Black Standard						
HEIGHT (H)	BASE WIDTH (BW)	PITCH (P)	WEIGHT (Per Foot/Lbs.)	CLEAT HEIGHT (Recommended)	D1 (Min. Pulley Dia.)	D2 (Min. Deflection Dia.)
6"	3"	2-13/32"	3.0	5-1/2"	14"	24"
8"	3"	2-13/32"	4.3	7"	16"	32"
10"	3"	2-13/32"	5.5	9"	20"	40"



Call Toll Free: 1-866-711-4673
International: +1-727-342-5086



LIGHTWEIGHT

MATERIALS
AND STYLESBlue Lycra
Covered Sponge

Gum

Neoprene
Sponge
(Closed Cell)Nitrile (White
or Black)Red Natural
RubberRoughtop
(Gum or Nitrile)Scrubber
Matting

Urethane Foam

Urethane Foam
Adhesive TopUrethane
Sheeting* Additional
coverings available
upon request.

LIGHTWEIGHT BELTING & CUSTOM FABRICATIONS

We are continually adding new products and expanding our capabilities to help you create the products you need. Our fabrications illustrate our capabilities utilizing new technology, modern equipment and cutting edge techniques. The outstanding quality of this workmanship relates directly to the solid experience and training of our belt fabricators. We offer all standard fabrications plus several of our own specialties.

CUSTOM COVERS & SPECIALTY BELTING

Designing equipment to perform in challenging environments calls for belt coverings that are up to the task.

SPECIALTY AND COVERED PRODUCTS

Products like these are highly effective in a variety of applications from vacuum systems to plucking feathers to orienting and pulling product down the line.

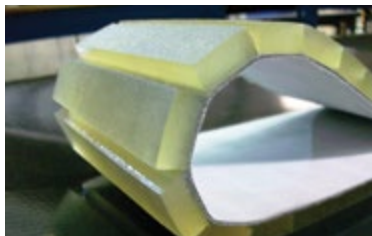

URETHANE FOAM COVERING

FSTF green urethane foam is created to coat and back flat belts, timing belts and V-profiles. Features include:

- ▶ Belt surface with high grip properties
- ▶ Excellent abrasion resistance
- ▶ Soft, yet durable coating
- ▶ Non-marking to the items being conveyed

Because the coating is made of urethane, we can heat-weld this product to the base belt and help you sidestep the higher production costs of chemical bonding.



CONDUCTIVE STRIP BELTS

Conductive strip belts enable the unique powder paint booth process.

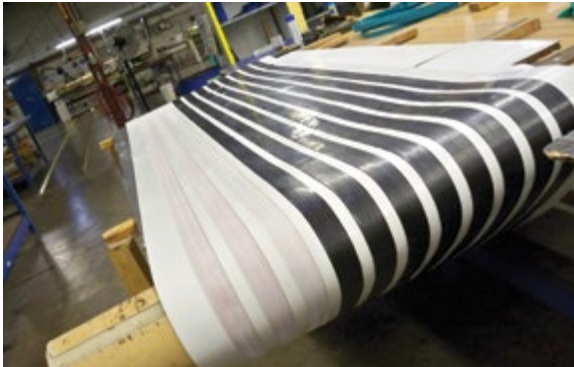
**CUSTOM COVERED AND SPLICED TIMING BELTS**

These belts can be supplied in urethane steel/Kevlar reinforced, SBR rubber, HTD, etc. We splice custom length H and L pitch SBR and neoprene timing belts.

**EDGE-CAPPING**

Edge capping is applied to exposed conveyor belt edges to avoid contamination of products, particularly in food applications, as well as the equipment with stringing from the plies/edge fray. Our high-frequency (HF) edge capping has a smaller edge when applied, making it less susceptible to pitting. When applied, this provides another level of hygiene by protecting the plies of our fabric belts from becoming saturated with fluids creating contamination with other harmful bacteria.





DRUM PULLEY

High-strength steel-faced pulleys: available with rubber lagging for improved traction.



WING PULLEY

Self-cleaning angled gussets remove excessive build-up, improving the efficiency of your conveyor system. Wing pulleys increase traction and reduce damage and abrasion on both the belt and the pulleys. Not recommended for cleated belts.

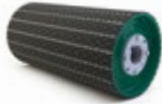

REPLACEABLE LAGGING

Vulcanized rubber bonded to metal backing that can be fitted or welded to the pulley face.

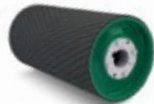

VULCANIZED RUBBER LAGGING

60 durometer SBR, available in oil-resistant and MSHA. Wide variety of thicknesses and grooving patterns available, such as herringbone, chevron, and diamond.



PULLEY LAGGING

For this method of pulley lagging, a long strip of rougtop is spiralled around the pulley from end-to-end and centered for good adhesion. The ends may be notched per sketch for neat application. Bolt or screw ends intermittently throughout. Length of strip is calculated as follows:

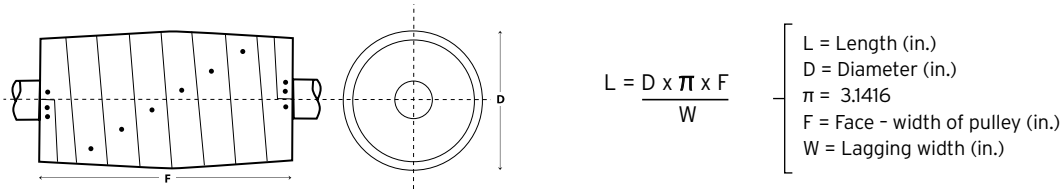

IDLERS AND CLEANERS

Troughing and return idlers are available in a number of styles, materials, and angles for any conveyor application. Several styles of continuous belt cleaners are available to prevent material build-up and reduce downtime.



Flat Idler

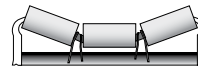

20-Degree Troughing Idler

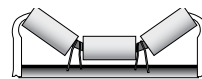

35-Degree

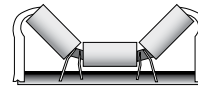

45-Degree



Cleaner/Scrapper

GOODYEAR
GOODYEARBELTING.COM

Call Toll Free: 1-866-711-4673
International: +1-727-342-5086

We Ship
World Wide

PRE-CUT SKIRT BOARD RUBBER

- ▶ Durometer: 60+/-5
- ▶ Sold in 50' rolls;
widths up to 48"

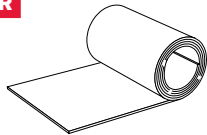

STANDARD SKIRTBOARD WIDTHS (INCHES) FROM INVENTORY

1/4" THICK

Width	4"	5"	6"	8"	10"	12"
Part #	60002200	60002210	60002214	60002209	NA	NA
Roll Weight	29#	36#	44#	58#	NA	NA

3/8" THICK

Width	4"	5"	6"	8"	10"	12"
Part #	60002220	60002230	60002240	60002249	60002250	60002251
Roll Weight	43#	54#	65#	86#	108#	129#

1/2" THICK

Width	4"	5"	6"	8"	10"	12"
Part #	60002255	60002260	60002260	60002277	60002280	60002400
Roll Weight	57#	71#	85#	114#	142#	170#

3/4" THICK

Width	4"	5"	6"	8"	10"	12"
Part #	NA	NA	60002426	60002428	60002430	60002429
Roll Weight	NA	NA	130#	174#	216#	260#

1" THICK

GOODYEAR
GOODYEARBELTING.COM

Call Toll Free: 1-866-711-4673
International: +1-727-342-5086

**We Ship
World Wide**

ELEVATOR BUCKETS AND BOLTS

Apache offers a variety of elevator buckets to meet the needs of your application, and an assortment of bolts.

ELEVATOR BOLTS

- ▶ Steel, zinc-plated, and stainless steel available.
- ▶ Bolts include nuts without washers.
- ▶ Also available are fanged and Norway bolts styles, nylon inserted lock-nuts, and locking or flat washers.

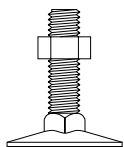

Flat Head

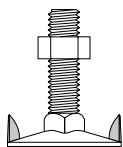

Fanged

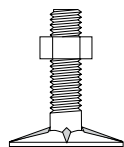

Norway

STEEL FLAT HEAD BOLTS

SIZE	QTY./BOX	LBS./BOX
1/4" x 3/4"	100	3.1
1/4" x 1"	100	3.2
1/4" x 1-1/4"	100	3.6
1/4" x 1-1/2"	100	3.9
5/16" x 1"	100	5.3
5/16" x 1-1/4"	100	5.8
5/16" x 1-1/2"	100	6.1
5/16" x 2"	100	7.3
3/8" x 1"	50	3.8
3/8" x 1-1/4"	50	4.0
3/8" x 1-1/2"	50	4.4
3/8" x 2"	50	5.0

ELEVATOR BUCKETS

Buckets are available in metal, nylon, urethane, and polyethylene to handle a variety of materials. The bolt holes can be punched in any required pattern.



ELEVATOR BUCKET PROJECTIONS

PVC ELEVATOR BELT

SPEC#	PART#	BELT DESCRIPTION	MAX. BUCKET PROJECTION	BELT COLOR
66A	20038199	PVC 150 Black CBS	4	Black
67B	20038509	2-Ply 220 1/16 x 1/16 PVGE	6	White
69A	20038206	PVC 200 Black ORSC CBS	6	Black
69B	20038500	PVC 250 Black ORSC CBS	6	Black
72	20039000	PVC 350 Black ORSC CBS	7	Black
73	20040009	PVC 450 Black ORSC CBS	8	Black
259	20040015	PVC 600 Black ORSC CBS	9	Black

RUBBER ELEVATOR BELT

SPEC#	PART#	BELT DESCRIPTION	MAX. BUCKET PROJECTION	BELT COLOR
23A	20021628	2-Ply 220 1/16 x 1/16 SCORFR Grain	6	Black
25A	20021630	3-Ply 330 1/16 x 1/16 SCORFR Grain	8	Black
27A	20021635	3-Ply 600 1/16 x 1/16 SCORFR Grain	10	Black
27B	20021640	4-Ply 440 1/16 x 1/16 SCORFR Grain	9	Black

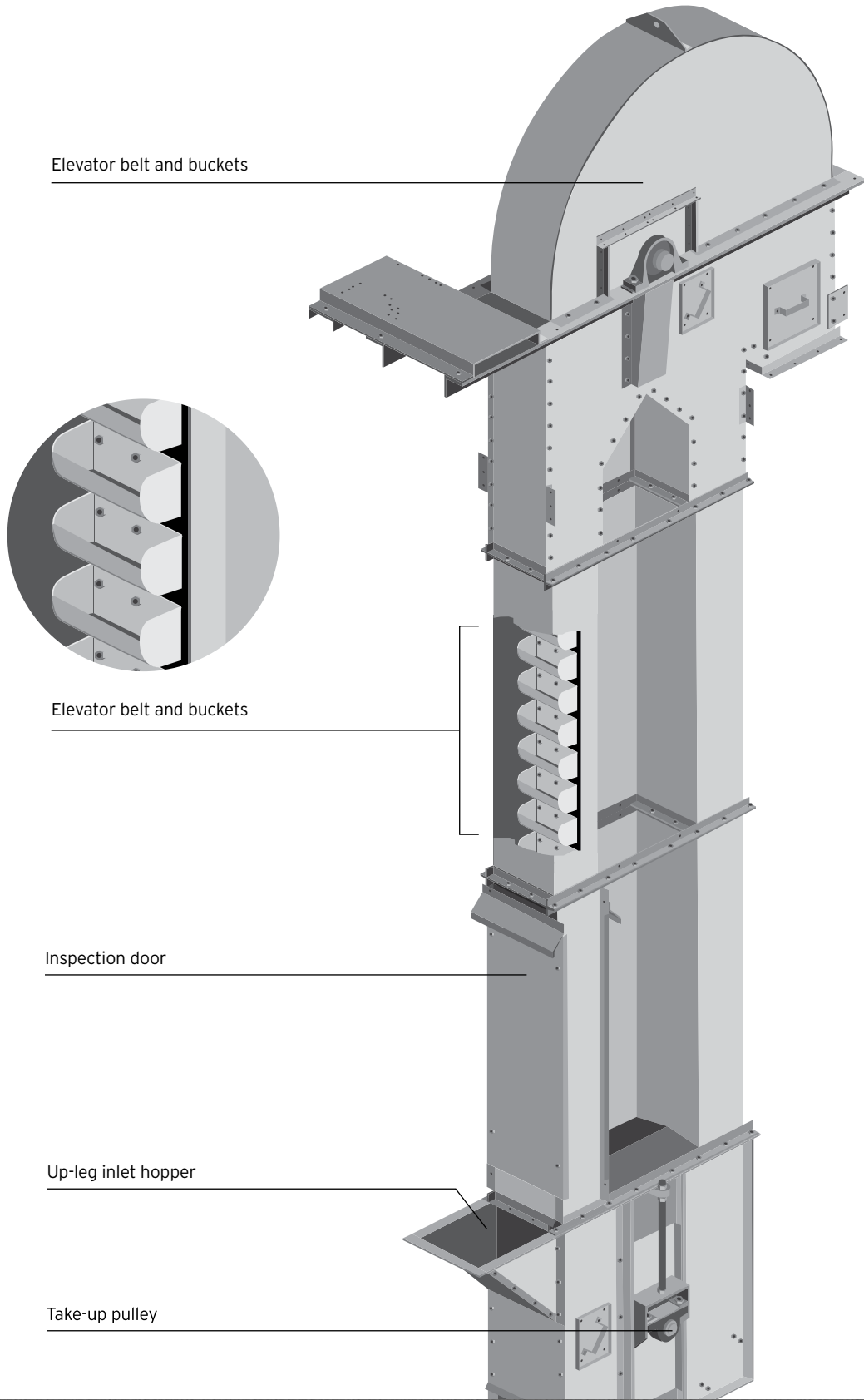

Elevator
Belt Punching
worksheet p. 95.



FRICITION PAD

Our friction pad is made with top-quality resins, and has conical-shaped perforations – ensuring stronger pin retention and better performance. With high durability and longer life, the friction pad offers a great option for original equipment replacement. It is available in 500' lengths as a replacement only.



POWER GRAVITY ROLLER BELT

The power gravity roller (PGR) belt, with its embossed top and brushed bottom, is designed for quiet operation and a long life. Its adhesive-free joining process increases productivity and lowers maintenance costs. The PGR belt works with your customers' existing tooling, and splices into the OEM belt, which provides even more cost savings.

VOLTA SPLICING TOOLS

A variety of tools are available for fabrication of Volta belting, including the following splicing tools for low-cost and easy installations.



FLAT BUTT WELDING SYSTEM

The FBW splicing tool is lightweight and easy to use, it requires only a standard electrical connection. This tool offers quick set-up and shortens downtime for the customer. The flat butt welding system is available to splice belts as narrow as 12" or up to 83" wide. A 230V press must be used for the maximum width of 83", and a 110V press offers a maximum width of 51". All profiles and flat belting are compatible for splicing with this equipment.



FT ELECTRODE WELDING SYSTEM

The FT electrode welding system is lightweight and easy to use. This system uses a router to cut the bevel on the belt edges and to trim the weld. A hot air gun and Volta electrode are used for this weld option. Different electrode sizes are selected based on the thickness of belt being spliced.

GOODYEAR
GOODYEARBELTING.COM

Call Toll Free: 1-866-711-4673
International: +1-727-342-5086

We Ship
World Wide

CUT & MOLDED PRODUCTS

We turn ideas into solutions. Our product and engineering staff are here to help, partnering with you to develop quality, cost-effective, cut and molded parts. Plus, with locations across the U.S., we provide fast customer response and service time.

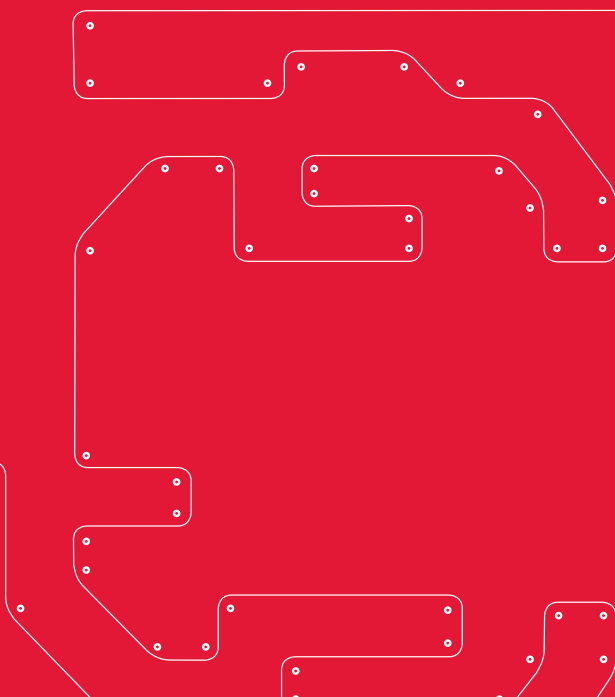

GOODYEAR
GOODYEARBELTING.COM

Call Toll Free: 1-866-711-4673
International: +1-727-342-5086

**We Ship
World Wide**

CUTTING PROCESSES

We produce our customers' parts using one of four cutting processes: waterjet, flashcut, die-cut and hand-cut.



WATERJET

Waterjet cutting allows for the precision cutting of custom parts when extremely tight tolerances are critical or complicated patterns are called for. This CNC-controlled process produces parts with exceptional quality and clean cut edges without causing thermal damage. What's more, the waterjet can be used to cut a wide range of materials and dimensions.



FLASHCUT

Die-less knife cutting offers the precision and tight tolerances of a waterjet without the use of water. The CNC-controlled flashcut operates on AutoCAD files like a waterjet, and is ideal for cutting soft and semi-rigid materials without the mess and cleanup of water cutting.



DIE-CUT

Die-cutting results in very precise parts with tight tolerances. It can be used to produce both low- and high-volume production runs in a wide range of materials.



HAND-CUT

Hand-cutting is often the right choice for certain limited quantity, lower-tolerance and prototype parts. Our craftsmen have the skill to produce prototypes and low-volume production runs from a wide variety of materials and for a range of industries.

GOODYEAR
GOODYEARBELTING.COM

Call Toll Free: 1-866-711-4673
International: +1-727-342-5086

**We Ship
World Wide**

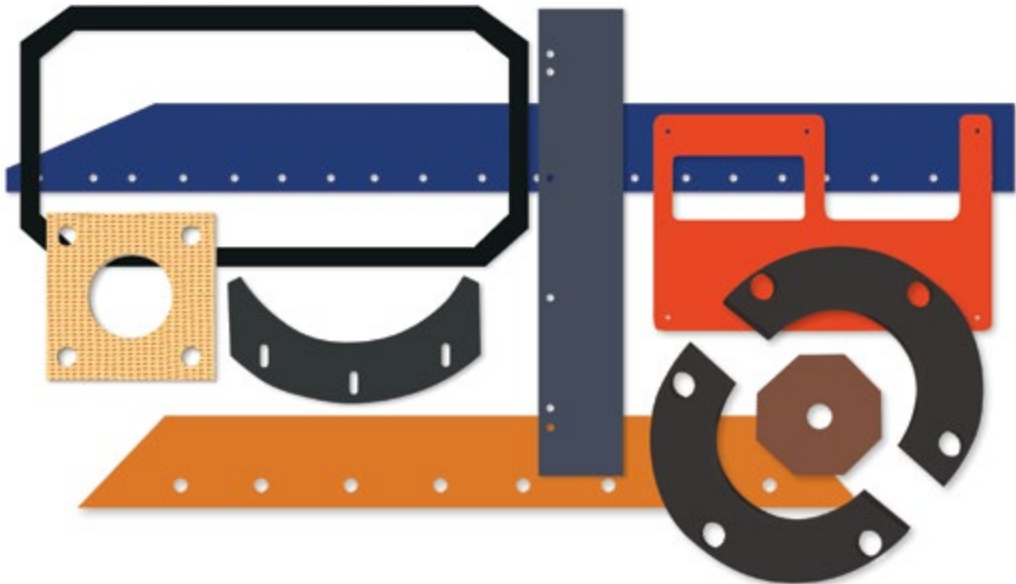

INDUSTRIES SERVED

- Agricultural
- Automotive
- Chemical
- Construction & Concrete
- Electrical
- Fitness
- Food & Beverage
- Government
- Heavy Equipment
- High-Tech
- Hydroelectric
- Industrial
- Irrigation
- Manufacturing
- Marine
- Material Handling
- Military
- Municipalities
- Oil & Gas
- Power Production
- Pulp & Paper
- Rail & Bridge
- Recreation
- Robotics
- Trucking & Transport
- Utilities
- Waste Water

CUT RUBBER MATERIAL OPTIONS

INDUSTRIAL GASKET AND SHEET PACKING MATERIALS

- ▶ Lightweight and heavy-duty rubber and PVC conveyor belt
- ▶ Lightweight thermoplastic belt
- ▶ Oil- and non-oil resistant rubber:
 - Diaphragm and cloth-inserted rubber sheet
 - Open and closed cell sponge and foam
 - Silicone rubber
 - Rubber sheet packing (all polymers)
 - Cork/rubber sheet
 - Masticated rubber
 - Pure gum (natural rubber)
 - White FDA food-grade rubber
 - Compressed non-asbestos sheet
- ▶ We work with the top material suppliers in the business, so if we don't happen to have it on the shelf, we can get it quickly.

SPECIALTY APPLICATION MATERIALS

- ▶ UHMW polyethylene (Ultra-High Molecular Weight)
- ▶ AASHTO shock and structural bearing material
- ▶ HDPE (High Density Polyethylene)
- ▶ Military specifications
- ▶ LDPE (Low Density Polyethylene)
- ▶ Ballistic materials
- ▶ Lining materials for abrasion and wear protection
- ▶ Various composite materials



Call Toll Free: 1-866-711-4673
International: + 1-727-342-5086





CUT RUBBER MATERIAL OPTIONS (CONTINUED)

COMMON SHEET PACKING POLYMERS

▶ **Butyl (IIR / isobutyl-isoprene):** Excellent weathering and dielectric properties with low air permeability. Good physical properties. Poor resistance to petroleum-based fluids.

TEMP: -30°F to +212°F

▶ **EPDM (ethylene-propylene diene):** Excellent ozone, chemical, heat and aging resistance. Poor resistance to petroleum-based fluids.

TEMP: -40°F to +250°F

▶ **Hypalon® (CSM / chloro-sulfonated polyethylene):** Excellent ozone, weathering, and acid resistance. Good abrasion and heat resistance. Fair resistance to petroleum-based fluids.

TEMP: -20°F to +170°F

▶ **Natural Rubber (NR / Gum Rubber):** Excellent physical properties, including abrasion and resistance. Good flexibility at low temperature. Poor resistance to petroleum-based fluids.

TEMP: -20°F to 180°F

▶ **Neoprene (CR / polychloroprene):** Good weather resistance and good inherent flame resistance. Moderate resistance to petroleum-based fluids. Good physical properties.

TEMP: -20°F to +180°F

▶ **Nitrile (NBR / Buna-N / butadiene-acrylonitrile):** Excellent resistance to petroleum-based fluids. Good physical properties.

TEMP: -40°F to +200°F

▶ **Silicone (SI / Dimethyl-Polysiloxane):** Excellent high and low temperature properties, fair physical properties.

TEMP: -80°F to +500°F

▶ **SBR (Styrene Butadiene Rubber):** Excellent abrasion resistance and low temperature properties.

TEMP: -20°F to +180°F

▶ **Urethane (polyurethane) :** Good aging and excellent abrasion, tear and solvent resistance. Poor high temperature properties.

TEMP: -58°F to +180°F

▶ **Viton® (FKM / Fluorocarbon - Elastomer Type A):** Excellent oil- and air-resistance at both low and high temperatures. Very good chemical resistance.

TEMP: -20°F to +450°F

GOODYEAR
GOODYEARBELTING.COM

Call Toll Free: 1-866-711-4673
International: + 1-727-342-5086

**We Ship
World Wide**

MOLDED RUBBER PARTS

We manufacture molded parts using modern computer-controlled and-monitored presses. We offer both compression and transfer molding production processes, and we can help you determine which method is best for your application.



COMMON PARTS

- Rings / Washers
- Truck & Industrial Bushings
- Cut Pads
- Cushion / Sound Strips
- Bumpers
- Grommets
- Plugs & Stoppers
- Vibration Mounts
- Bellows
- Seals
- Recycling Stars
- Flanges
- Solid / Hollow Profiles
- Blocks
- Special Transition Corners

COMPRESSION MOLDING

Compression molding is ideal for products with industrial tolerances (typically RMA Commercial-A3). This process produces less scrap material weight and the tooling typically costs less than other transfer molding. Product sizes range from very small to up to 12 feet long.

TRANSFER MOLDING

Transfer molding can produce tighter tolerance parts than compression molding and generally leaves less flash on the mold parting line.

COMMON MOLDING MATERIAL OPTIONS		
▶ Neoprene	▶ Isoprene (Synthetic rubber)	▶ EPDM
▶ Natural rubber	▶ Silicone	▶ Hypalon®
▶ SBR	▶ Nitrile (Buna-N)	▶ Viton®



Call Toll Free: 1-866-711-4673
International: + 1-727-342-5086



CUT & MOLDED
PRODUCTS

OTHER SPECIALTY SERVICES



GOODYEAR
GOODYEARBELTING.COM

Call Toll Free: 1-866-711-4673
International: +1-727-342-5086

**We Ship
World Wide**

CUSTOM FABRICATIONS / SPECIALTY SERVICES

- | | | |
|---|---------------|----------------|
| ▶ Boots/sleeves | ▶ Slitting | ▶ Sub-assembly |
| ▶ Hole punching/perforating | ▶ Splicing | ▶ Labeling |
| ▶ Laminating | ▶ Stripping | ▶ Packaging |
| ▶ PSA application (pressure sensitive adhesive) | ▶ Vulcanizing | ▶ Kitting |

RUBBER VULCANIZATION AND RUBBER-TO-METAL BONDING

Parts for vulcanization and rubber-to-metal bonding require specific preparation processes to ensure proper adhesion of the materials. The team at Apache will design a process for your parts that meet the requirements of your industry and application.

COMPOUNDING / BLENDING CAPABILITIES

Standard and custom-blended compounds are produced to your requirements in specific batch sizes made for each application and production run. Small prototype or large production batch runs are available for almost any size, shape or quantity of extruded or molded product.

GOODYEAR
GOODYEARBELTING.COM

Call Toll Free: 1-866-711-4673
International: +1-727-342-5086

**We Ship
World Wide**

REFERENCE CHARTS

Need more detailed information about any of our belting materials? Use the following charts – which include resistance ratings for an exhaustive list of chemicals – to pick the right belt for you application.

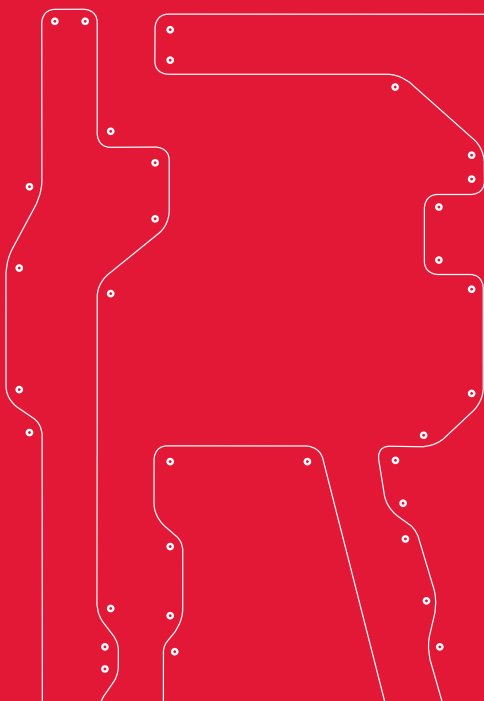

CHEMICAL RESISTANCE

CHEMICAL RESISTANCE CHART										
	PVC Poly Vinyl Chloride	RAV Rubber & Vinyl	URETHANE	SBR	NBR	MOR	SOR	EPDM	BUTYL	NATURAL RUBBER
Temperature Range	0°F to 180°F	-20°F to 180°F	-20°F to 180°F	-25°F to 250°F	0°F to 250°F	-20°F to 200°F	-10°F to 200°F	-20°F to 400°F	-65°F to 300°F	-40°F to 200°F
Abrasion Resistance	Good	Good	Excellent	Excellent	Good	Good	Good	Good	Fair	Excellent
Cut/Gouge Resistance	Good	Good	Excellent	Good	Good	Good	Good	Good	Good	Excellent
Oil Resistance	Good	Excellent	Excellent	Not Recommended	Excellent	Good	Excellent	Not Recommended	Not Recommended	Not Recommended
CHEMICAL										
Acetaldehyde	NR	NR	NR	NR	NR	NR	NR	G	G	F
Acetic Acid-Glacial	NR	NR	E	F	NR	NR	NR	F	E	F
Acetic Acid-30%	E	E	E	F	F	F	F	F	F	F
Acetic Anhydride	F	F	NR	F	NR	F	F	NR	F	F
Acetone	NR	NR	NR	NR	NR	NR	NR	F	G	NR
Alcohols	F	G	NR	G	E	G	E	G	E	G
Aluminum Chloride	E	E	E	E	E	E	E	E	E	E
Alumina Non-Activated	NR	NR	E	G	E	E	E	E	E	G
Alumina Nitrate	E	E	E	E	E	E	E	E	E	E
Ammonium Carbonate	E	E	E	E	NR	E	E	E	E	E
Ammonium Hydroxide (dil)	E	U	E	NR	NR	NR	NR	E	E	NR
Ammonium Nitrate	E	E	E	E	E	E	E	E	E	F
Ammonium Persulfate	NR	NR	NR	NR	NR	NR	NR	E	E	E
Ammonium Phosphate	G	E	E	E	E	E	E	E	E	G
Ammonium Sulfate	G	E	E	G	E	E	E	E	E	E
Aniline Dyes	G	G	G	G	NR	F	NR	G	G	G
Animal Fats	NR	G	G	NR	G	F	G	G	G	NR
Asphalt-Hot	NR	NR	E	NR	G	NR	NR	NR	NR	NR
Barium Chloride	E	E	E	E	E	E	E	E	E	E
Barium Hydroxide	E	E	E	E	E	E	E	E	E	E
Barium Sulfide	E	E	E	G	E	E	E	E	E	E
Benzene	NR	NR	NR	NR	NR	NR	NR	NR	NR	NR
Benzyl Alcohol	F	U	NR	NR	NR	NR	NR	NR	G	NR
Borax	E	E	E	G	G	G	G	E	E	G
Boric Acid (dil)	E	E	E	E	E	E	E	E	E	E
Brine	E	E	E	E	E	E	E	E	E	E
Bunker Oil	F	U	E	NR	E	F	E	NR	NR	NR
Butter	F	G	G	NR	E	NR	G	F	G	NR
Butyl Acetate	NR	NR	NR	NR	NR	NR	NR	G	G	NR
Butylaldehyde	NR	NR	F	NR	F	NR	NR	G	G	NR
Calcium Bisulfite	NR	NR	NR	NR	NR	NR	NR	NR	NR	NR
Calcium Chloride	E	E	E	E	E	E	E	E	E	E
Calcium Hydroxide	E	E	E	E	E	E	E	E	E	E
Calcium Hypochlorite	G	U	E	NR	F	F	F	E	E	NR
Calcium Nitrate	E	E	E	E	E	E	E	E	E	E
Calcium Sulfide	E	E	E	G	G	F	G	E	E	G
Caliche (Sodium Nitrate)	E	E	E	G	G	G	G	E	E	G
Carbolic Acid-attacks PE/Nylon	NR	NR	E	NR	NR	NR	NR	NR	NR	NR
Carbon Bisulfide	NR	NR	NR	NR	F	NR	F	NR	NR	NR
Carbon Tetrachloride	NR	NR	NR	NR	F	NR	NR	NR	NR	NR
Castor Oil	F	E	F	NR	E	F	E	G	G	NR
Cellosolve	NR	NR	G	NR	NR	NR	NR	G	G	NR
Chinawood Oil	NR	U	NR	NR	G	F	G	NR	G	NR
Chlorinated Solvents	NR	NR	G	NR	NR	NR	NR	NR	NR	NR
Chlorine Solutions	E	E	NR	G	G	G	G	E	E	G
Chrome Plating Solutions	F	U	E	NR	NR	NR	NR	NR	NR	NR
Chromic Acid	NR	NR	NR	NR	NR	NR	NR	F	F	NR
Citric Acid	E	E	NR	E	E	E	E	E	E	E
Coal-Oil Treated	F	U	E	NR	E	G	E	NR	NR	NR
Coconut Oil	F	E	E	NR	E	F	E	E	E	NR
Copper Chloride	E	E	E	E	E	E	E	E	E	E
Copper Sulfate	E	E	E	G	E	E	E	E	E	G
Corn Oil	NR	E	G	NR	G	F	G	F	G	NR
Cotton Seed Oil	NR	G	G	NR	G	F	G	E	F	NR
Cresol-Attacks PE/Nylon	NR	NR	NR	NR	NR	NR	NR	NR	NR	NR
Creosote	F	U	E	NR	G	NR	NR	NR	NR	NR
Cresylic Acid	NR	NR	NR	NR	F	NR	NR	NR	NR	NR
Denatured Alcohol	E	G	F	E	E	E	E	E	E	E
Developing Liquids	E	E	E	G	E	G	E	G	G	E
Diacetone Alcohol	NR	NR	NR	NR	NR	NR	NR	E	E	NR
Diesel Oil	F	E	E	NR	E	F	E	NR	NR	NR
Diethylene Glycol	E	U	E	G	E	E	E	E	E	G

	PVC Poly Vinyl Chloride	RAV Rubber & Vinyl	URETHANE	SBR	NBR	MOR	SOR	EPDM	BUTYL	NATURAL RUBBER
Temperature Range	0°F to 180°F	-20°F to 180°F	-20°F to 180°F	-25°F to 250°F	0°F to 250°F	-20°F to 200°F	-10°F to 200°F	-20°F to 400°F	-65°F to 300°F	-40°F to 200°F
Abrasion Resistance	Good	Good	Excellent	Excellent	Good	Good	Good	Good	Fair	Excellent
Cut/Gouge Resistance	Good	Good	Excellent	Good	Good	Good	Good	Good	Good	Excellent
Oil Resistance	Good	Excellent	Excellent	Not Recommended	Excellent	Good	Excellent	Not Recommended	Not Recommended	Not Recommended
CHEMICAL										
Ferric Chloride	E	E	E	E	E	E	E	E	E	E
Ferric Sulfate	E	E	E	E	E	E	E	E	E	E
Formaldehyde (Aqueous)	E	E	E	NR	G	F	G	E	E	NR
Formic Acid-Attacks Nylon	NR	NR	NR	NR	NR	NR	NR	NR	NR	NR
Fuel Oil	F	E	E	NR	E	F	E	NR	NR	NR
Furfural	NR	G	NR	NR	E	NR	F	G	G	NR
Gasoline	NR	E	G	NR	E	F	G	NR	NR	NR
Gelatin	E	E	E	E	E	E	E	E	E	E
Glucose	E	E	E	E	E	E	E	E	E	E
Glycerine	E	E	E	E	E	E	E	E	E	E
Glycols	F	U	E	E	E	E	E	E	E	E
Green Sulphate Liquor	E	U	G	G	G	G	G	E	E	G
Hydraulic Oil	NR	G	NR	NR	G	G	G	NR	NR	NR
Hydrochloric Acid (dil)	E	E	E	G	G	G	G	E	E	G
Hydrogen Peroxide	E	U	NR	NR	NR	NR	NR	F	F	NR
Hydrobromic Acid (dil)	E	E	E	F	NR	E	E	E	E	E
Isoctane (Gasoline)	NR	NR	E	NR	E	NR	NR	NR	NR	NR
Isopropyl Acetate	NR	NR	NR	NR	NR	NR	NR	E	E	NR
Kerosene	NR	G	G	NR	G	NR	G	NR	NR	NR
Lacquers	NR	F	NR	NR	NR	NR	NR	NR	NR	NR
Lacquer Solvents	NR	NR	NR	NR	NR	NR	NR	NR	NR	NR
Lactic Acid	E	E	E	E	E	E	E	E	E	E
Lard	NR	G	G	NR	G	F	G	NR	NR	NR
Latex Adhesive	G	U	NR	NR	E	F	G	NR	NR	NR
Lime Sulfur	F	U	NR	NR	NR	NR	NR	E	E	NR
Limestone	E	E	E	E	E	E	E	E	G	E
Linolic Acid	F	F	G	NR	G	NR	G	F	F	NR
Linseed Oil	G	G	NR	NR	E	F	E	G	G	NR
Lube Oil	F	U	E	NR	E	F	E	NR	NR	NR
Lubricating Oils	F	E	E	NR	E	F	E	NR	NR	NR
Magnesium Chloride	E	E	E	E	E	E	E	E	E	E
Magnesium Hydroxide	E	E	E	G	G	G	G	E	E	G
Magnesium Sulfate	E	E	E	G	E	E	E	E	E	G
Meat and Bone Meal	NR	U	G	NR	G	F	G	NR	NR	NR
Methyl Alcohol	G	G	E	E	E	E	E	E	E	E
Methyl Butyl Ketone	NR	NR	G	NR	NR	NR	NR	E	E	NR
Methyl Ethyl Ketone	NR	NR	G	NR	NR	NR	NR	E	E	NR
Milk	E	E	E	E	E	E	E	E	E	E
Mineral Oil	F	E	E	NR	F	F	E	NR	G	NR
Mineral Spirits	NR	E	G	NR	NR	NR	NR	E	F	NR
Molasses	E	E	E	E	E	E	E	E	E	E
Mustard	NR	U	G	NR	G	F	G	NR	NR	NR
Naptha	NR	F	F	NR	F	NR	F	NR	NR	NR
Nickle Chloride	E	E	E	E	E	E	E	E	E	E
Nickel Sulfate	E	E	E	G	E	E	E	E	E	G
Nitric Acid (dil)	E	E	NR	NR	NR	NR	NR	G	G	NR
Oleic Acid	NR	U	G	G	F	F	F	G	G	G
Olive Oil	NR	U	G	NR	E	F	G	G	G	NR
Oil Sands	F	E	E	NR	E	F	E	NR	NR	NR
Oil Shale	F	E	E	NR	E	F	E	NR	NR	NR
Oxalic Acid	E	U	E	G	G	F	G	E	E	G
Oxygen	E	E	E	G	G	G	G	E	E	G
Ozone	E	E	E	NR	NR	NR	NR	E	G	NR
Palmitic Acid	NR	U	G	G	E	G	E	G	G	G
Paraffin	G	E	F	NR	E	G	E	G	G	NR
Peanut Oil	NR	E	G	NR	G	F	G	G	F	NR
Peel Oil	NR	U	G	NR	G	F	G	G	F	NR
Perchloric Acid	NR	NR	NR	NR	NR	NR	NR	G	G	NR
Petroleum Oils	F	G	E	NR	E	F	E	NR	G	NR
Phenol-Attacks PE/Nylon	E	NR	G	NR	NR	NR	NR	NR	NR	NR
Phosphate Ore	G	G	E	E	E	E	E	E	E	E
Phosphate-Processed	G	F	E	F	NR	F	F	G	G	F
Phosphoric Acid (dil)	E	E	E	F	G	F	G	E	E	G
Pine Oil	F	E	G	NR	G	F	G	NR	NR	NR

	PVC Poly Vinyl Chloride	RAV Rubber & Vinyl	URETHANE	SBR	NBR	MOR	SOR	EPDM	BUTYL	NATURAL RUBBER
Temperature Range	0°F to 180°F	-20°F to 180°F	-20°F to 180°F	-25°F to 250°F	0°F to 250°F	-20°F to 200°F	-10°F to 200°F	-20°F to 400°F	-65°F to 300°F	-40°F to 200°F
Abrasion Resistance	Good	Good	Excellent	Excellent	Good	Good	Good	Good	Fair	Excellent
Cut/Gouge Resistance	Good	Good	Excellent	Good	Good	Good	Good	Good	Good	Excellent
Oil Resistance	Good	Excellent	Excellent	Not Recommended	Excellent	Good	Excellent	Not Recommended	Not Recommended	Not Recommended
CHEMICAL										
Rapeseed Oil	NR	U	G	NR	G	F	G	E	E	NR
Salicylic Acid	E	E	E	G	E	G	E	E	E	E
Salt Water	E	E	E	E	E	E	E	E	E	E
Sewage	F	F	E	NR	E	F	E	F	NR	NR
Shellac (flakes)	E	E	E	E	E	E	E	E	E	E
Silicone Oil	F	E	E	F	E	G	E	G	E	F
Soap Solutions	E	U	E	G	E	E	E	E	E	G
Soda Ash	E	E	E	E	E	E	E	E	E	E
Sodium Bicarbonate	E	E	E	E	E	E	E	E	E	E
Sodium Bisulfate	E	E	E	G	E	G	E	E	E	E
Sodium Chloride	E	E	E	E	E	E	E	E	E	E
Sodium Hydroxide (dil)	E	E	E	E	G	E	G	E	E	E
Sodium Hypochlorite	E	E	E	F	G	F	G	G	G	F
Sodium Nitrate	E	E	E	G	G	G	G	E	E	G
Sodium Perborate	E	U	E	G	G	G	G	E	E	G
Sodium Peroxide	E	E	E	G	G	G	G	E	E	G
Sodium Phosphates	E	E	E	E	E	E	E	E	E	E
Sodium Silicate	E	E	E	E	E	E	E	E	E	E
Sodium Sulfate	E	E	E	G	E	E	E	E	E	G
Sodium Sulfide	E	E	E	F	NR	F	F	G	E	F
Sodium Thiosulfate	E	E	E	G	G	G	G	E	G	G
Sodium Chloride	E	E	E	E	E	E	E	E	E	E
Soybean Oil	F	E	U	F	E	U	U	U	U	U
Stearic Acid	G	U	E	F	F	F	F	F	E	F
Sugar Beets	E	E	E	E	E	E	E	E	F	E
Sugar Cane	E	E	E	E	E	E	E	E	E	E
Sugar Syrup	E	E	E	E	E	E	E	E	E	E
Sulfur	E	E	E	NR	NR	NR	NR	E	E	NR
Sulfuric Acid (dil)	E	E	E	F	NR	F	F	G	E	F
Sulfurous Acid	E	E	E	F	NR	F	F	G	G	F
Sunlight	E	E	E	G	G	G	G	G	G	G
Tannic Acid	E	E	E	G	E	G	E	E	E	G
Tanning Liquor	F	U	G	NR	G	F	G	NR	E	NR
Tar, Bituminous	F	E	E	NR	E	F	G	NR	NR	NR
Tartaric Acid	E	E	E	G	E	G	E	G	NR	G
Tetrachloroethylene	NR	NR	NR	NR	NR	NR	NR	NR	G	NR
Touene (Toluol)	NR	F	NR	NR	F	NR	F	NR	NR	NR
Transformer Oil	F	U	G	NR	E	F	E	NR	NR	NR
Transmission-Type A	F	U	G	NR	E	G	E	NR	NR	NR
Trichloroethylene	NR	NR	NR	NR	F	NR	NR	NR	NR	NR
Trichloroethane	NR	NR	NR	NR	NR	NR	NR	NR	NR	NR
Tricresyl Phosphate	F	U	NR	NR	NR	NR	NR	F	E	NR
Trisodium Phosphate	E	E	E	E	E	E	E	E	E	E
Tung Oil	F	U	G	NR	E	G	E	F	F	NR
Turpentine	NR	F	NR	NR	R	G	E	NR	NR	NR
Ultra-Violet (moderate exposure)	E	E	E	G	G	G	G	E	E	F
Urea	E	E	E	E	E	E	E	E	E	E
Urine	E	E	G	G	G	G	G	G	G	G
Vegetable Oils	NR	E	G	NR	E	G	E	F	F	NR
Vinegar	E	E	E	G	G	G	G	E	E	G
Water	E	E	E	E	E	E	E	E	E	E
Whiskey	G	G	E	E	E	E	E	E	E	E
Wines	G	G	G	E	E	E	E	E	E	E
White Pine Oil	F	U	G	NR	E	G	E	NR	NR	NR
White Oil	F	U	E	NR	E	G	E	NR	NR	NR
Wood Oil	F	E	E	NR	E	G	E	NR	NR	NR
Wood Chips	G	G	E	F	E	G	E	NR	NR	F
Xylene-Attacks Nylon	NR	NR	NR	NR	NR	NR	NR	NR	NR	NR
Zinc Chloride	E	E	E	E	E	E	E	E	E	E
Zinc Sulphate	E	E	E	G	E	E	E	E	E	G

PVC – Poly Vinyl Chloride (PVC) is biologically and chemically resistant. PVC can be formulated to meet fire resistant and anti-static requirements.

RAV – Rubber and Vinyl (RAV), also known as RMV, is a refined PVC formulation. It offers high resistance to fats, oils and chemicals. It is a popular compound for use in food applications.

Urethane – Urethane is a good choice for rough and/or oily applications. It enjoys excellent

MOR – MOR stands for Moderate Oil Resistance. This compound performs well in wood, agriculture and light industrial applications where limited oils are present.

SOR – Super Oil Resistance (SOR) engenders extra oil resistance. It is used in high oil applications such as asphalt manufacture.

EPDM – Ethylene Propylene Diene Methylene Tripolymer (EPDM) is a formulation designed for

CONVEYOR BELT SPEEDS & FORMULAS

CONVEYOR BELT SPEEDS Pulley Revolutions Per Minute & Formulas		BELT SPEEDS IN FEET PER MINUTE								
DIAMETER OF PULLEY IN INCHES	PULLEY CIRCUMFERENCE IN FEET	100	150	200	250	300	350	400	500	600
		PULLEY REVOLUTIONS PER MINUTE								
12	3.14	31.8	47.7	63.7	79.6	95.6	111.4	127.3	159.2	191.0
14	3.67	27.2	40.8	54.5	68.2	81.7	95.5	109.1	136.4	163.7
16	4.18	23.9	35.8	47.8	59.8	71.8	85.0	95.5	119.4	143.2
18	4.72	21.1	31.8	42.4	53.0	63.6	74.2	84.9	106.1	127.3
20	5.24	19.1	28.6	38.2	47.7	57.2	66.8	76.4	95.5	114.6
24	6.28	16.0	23.9	31.9	39.8	47.8	55.7	63.7	79.7	95.5
26	6.80	14.7	22.0	29.4	36.7	44.2	51.5	58.8	73.5	88.1
28	7.32	13.7	20.5	27.3	34.2	41.0	47.8	54.7	68.3	81.9
30	7.85	12.7	19.1	25.5	31.8	38.2	44.6	51.0	63.7	76.4
32	8.37	11.9	17.9	23.9	29.8	35.8	41.8	47.7	59.7	71.6
36	9.42	10.6	15.9	21.2	26.5	31.8	31.8	45.5	53.0	63.7

TO OBTAIN	HAVING	FORMULA
Belt speed feed per minute	Diameter (D) of pulley inches and revolutions per minute (RPM)	$S = 0.2618 \times D \times \text{RPM}$
Shaft Speed revolutions per minute (RPM)	Velocity (S) ft. per minute and diameter (D) of pulley inches	$\text{RPM} = \frac{S}{0.2618 \times D}$
Diameter (D) of pulley inches	Velocity (S) ft. per minute and revolutions per minute (RPM)	$D = \frac{S}{0.2618 \times \text{RPM}}$

CALCULATING BELT LENGTH	
KEY TO SYMBOLS	BELT LENGTH
C - Center to Center distance (inches)	For a two pulley system with no snub pulley:
D - Diameter of Drive Pulley (inches)	$L = \frac{D + d}{2} \times 3.1416 + 2C$
d - Diameter of Tail Pulley (inches)	
L - Belt Length (inches)	

Must consider position of take up at tensions pulley when determining final length.

CONVEYOR BELT DIAGRAM

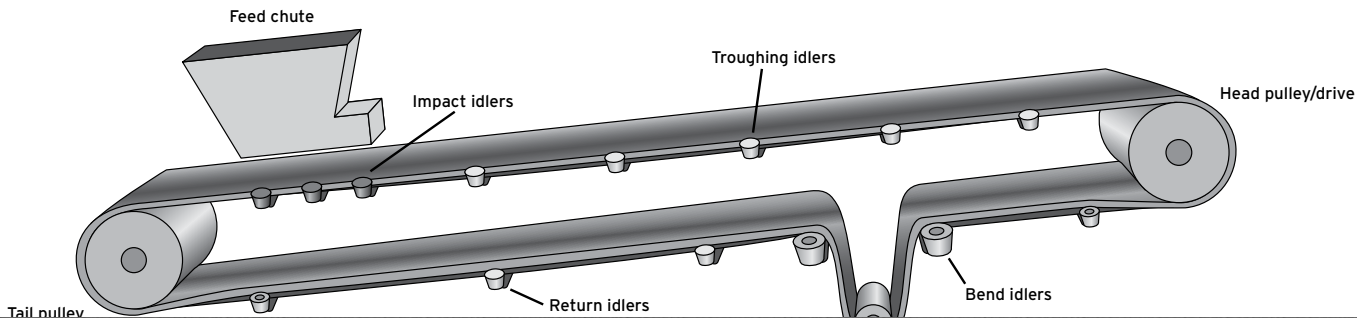

Call Toll Free: 1-866-711-4673
International: +1-727-342-5086



CONVERSIONS

CONVEYOR DESIGN INFORMATION <small>Decimal & Metric Equivalents</small>								
FRACTIONS OF AN INCH	EQUIVALENTS		FRACTIONS OF AN INCH	EQUIVALENTS		FRACTIONS OF AN INCH	EQUIVALENTS	
	Inches	Millimeters		Inches	Millimeters		Inches	Millimeters
1/64	0.015625	0.396875	23/64	0.359375	9.128125	11/16	0.6875	17.4625
1/32	0.03125	0.79375	3/8	0.3750	9.5250	45/64	0.703125	17.859375
3/64	0.046875	1.190625	25/64	0.390625	9.921875	23/32	0.71875	18.25625
1/16	0.0625	1.5875	13/32	0.40625	10.31875	47/64	0.734375	18.653125
5/64	0.078125	1.984375	27/64	0.421875	10.715625	3/4	0.7500	19.0500
3/32	0.09375	2.38125	7/16	0.4375	11.1125	49/64	0.765625	19.446875
7/64	0.109375	2.778125	29/64	0.453125	11.509375	25/32	0.78125	19.84375
1/8	0.1250	3.1750	15/32	0.46875	11.90625	51/64	0.796875	20.240625
9/67	0.140625	3.571875	31/64	0.484375	12.303125	13/16	0.8125	20.6375
5/32	0.15625	3.96875	1/2	0.5000	12.700	53/64	0.828125	21.034375
11/64	0.171875	4.365625	33/64	0.515625	13.096875	27/32	0.84375	21.43125
3/16	0.1875	4.7625	17/32	0.53125	13.49375	55/64	0.859375	21.828125
13/64	0.203125	5.159375	35/64	0.546875	13.890625	7/8	0.8750	22.2250
7/32	0.21875	5.55625	9/16	0.5625	14.2875	57/64	0.890625	22.621875
15/64	0.234375	5.93125	37/64	0.578125	14.684375	29/32	0.90625	23.01875
1/4	0.2500	6.3500	19/32	0.59375	15.08125	59/64	0.921875	23.415625
17/64	0.265625	6.756875	39/64	0.609375	15.478125	15/16	0.9375	23.8125
9/32	0.28125	7.14375	5/8	0.6250	15.8750	61/64	0.953125	24.209375
19/64	0.296875	7.540625	41/64	0.640625	16.271875	31/32	0.96875	24.60625

<input type="checkbox"/> BELT TYPE
<ul style="list-style-type: none"> ▶ Exact length: ▶ Exact width: ▶ Overall gauge (belt thickness): ▶ Color: ▶ Ply:
<input type="checkbox"/> FABRICATIONS
Lacing
<ul style="list-style-type: none"> ▶ Mechanical fastener: ▶ Standard, recessed, overlap, hidden:
Endless
<ul style="list-style-type: none"> ▶ Vulcanized skived splice: ▶ Finger splice: ▶ Double finger splice: ▶ Prepared ends for finger: ▶ Prepared ends skived:
Custom Cleating
<ul style="list-style-type: none"> ▶ Cleat style: ▶ Height (in.): ▶ Centers:
Tracking Guides
<ul style="list-style-type: none"> ▶ Tracking guide size:

<input type="checkbox"/> CONVEYOR SYSTEM ANALYSIS
<ul style="list-style-type: none"> ▶ Belt length: ▶ Belt width: ▶ Belt style: ▶ Minimum pulley diameter: ▶ Head pulley diameter: ▶ Tail pulley diameter: ▶ Live load/FT: ▶ Conveyor type: ▶ Drive configuration: ▶ Belt speed FPM: ▶ Conveyor length: ▶ Conveyor width (between frames): ▶ Conveyor slope: ▶ Product being conveyed: ▶ Food product: ▶ Ambient temperature: ▶ Product temperature: ▶ Oil condition: ▶ Chemical condition:
<input type="checkbox"/> PREVIOUS BELT HISTORY
<ul style="list-style-type: none"> ▶ Style:

GOODYEAR
GOODYEARBELTING.COM

Call Toll Free: 1-866-711-4673
International: +1-727-342-5086

We Ship
World Wide

LIGHTWEIGHT DUROWALL™ DESIGN WORKSHEET

NAME:

COMPANY:

PHONE #:

EMAIL:

DATE:

Here's what we need from you.

To ensure your belt is manufactured with a proper sidewall specification, please refer to the below diagrams and complete the following:

■ BELT STYLE
▶ Part number:
▶ Description:
■ BELT LENGTH AND WIDTH:
▶ Length:
▶ Width (see illustration, #1):
■ MINIMUM PULLEY DIAMETER:
■ SIZE OF SIDEWALL (#2):
■ PLEASE NOTE PLACEMENT OF SIDEWALL:
▶ Flush with edge of belt:
▶ Indent from belt edge to corrugation (#3):
■ INSIDE SPACE BETWEEN SIDEWALL:
▶ Center to center of sidewall (#4):
▶ Inside corrugation to inside corrugation (#5):
■ NOTE PLACEMENT OF CLEATS (IF APPLICABLE):
▶ Cleat height:
▶ Cleat spacing:
▶ Cleat width:
▶ Style: T-cleat, scoop, lug:
▶ Flush to foot of wall / flush to corrugation / indent from sidewall cleat?
▶ Additional sidewall to be left loose for field joining?

DUROWALL™ DIMENSIONS

MM	INCH	MM	INCH	MM	INCH	MM	INCH	MM	INCH
30	1-1/4	40	1-1/2	50	2	60	2-3/8	80	3-1/8
30	1-3/16	30	1-3/16	60	2-3/8	60	2-3/8	60	2-3/8
19	3/4	19	3/4	40	1-1/2	40	1-1/2	40	1-1/2
22	7/8	22	7/8	40	1-9/16	40	1-9/16	40	1-9/16

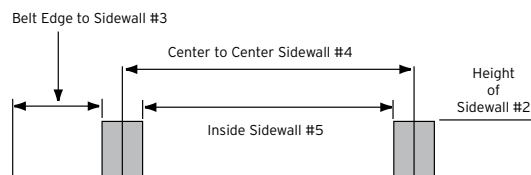
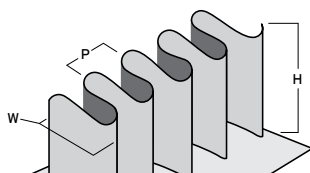

GOODYEAR
GOODYEARBELTING.COM

Call Toll Free: 1-866-711-4673
International: +1-727-342-5086

**We Ship
World Wide**

HEAVY-DUTY DUROWALL™ DESIGN WORKSHEET

NAME:

COMPANY:

PHONE #:

EMAIL:

DATE:

Here's what we need from you.

Copies of this data sheet can be used to help determine your belting requirements. Accurate and complete information is necessary to recommended the proper solution for your application.

CONTACT INFORMATION

▶ City:	State:	Zip:	
▶ Contact:	Phone:	Fax:	
▶ Reference Info.:			
▶ Material:			
▶ Density:	Size:	Min:	Max:
▶ Surcharge:	Temperature:	Min:	Max:
▶ Capacity:	Belt speed (check ___ if maximum):		
▶ Width preference:	Pulley diameter (check ___ if maximum):		
▶ Oil resistance required? <input type="checkbox"/> Yes <input type="checkbox"/> No			

EXISTING BELT SPECIFICATION FOR REPLACEMENT PART/PRICING

CROSS SECTION OF BELT

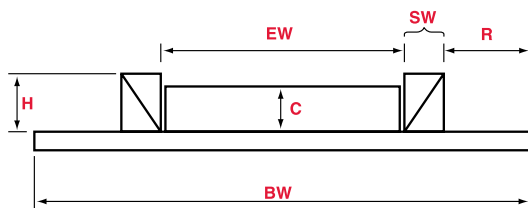

CROSS SECTION OF BELT

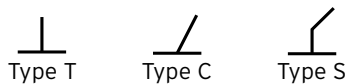

SIDE VIEW OF CONVEYOR

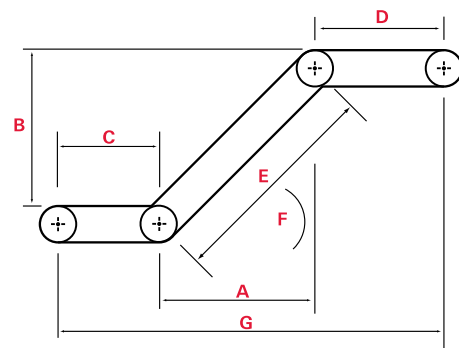

▶ Belt length:	▶ Belt type:	▶ Horizontal of incline (A):
▶ Belt width (BW):	▶ Pulley dia.:	▶ Lift (B):
▶ Sidewall height (H):	▶ Defl. dia.:	▶ Infeed/or horiz. conv. (C):
▶ Sidewall recess (R):	▶ Cleat type:	▶ Discharge (D):
▶ Sidewall width (SW):	▶ Cleat spacing:	▶ Incline length (E):

GOODYEAR
GOODYEARBELTING.COM

Call Toll Free: 1-866-711-4673
International: +1-727-342-5086

**We Ship
World Wide**

ELEVATOR BELT PUNCHING DIAGRAM WORKSHEET

Here's what we need from you.

NAME:

COMPANY:

PHONE #:

FAX #:

EMAIL:

DATE:

REF P.O. #:

PUNCHING DIAGRAM MUST BE SIGNED AND APPROVED BEFORE PRODUCTION BEGINS.

Please follow these instructions:

- 1 Draw in all holes to be punched, clearly indicating dimensions from the center line.
- 2 If there is only one row of holes across the belt per bucket, cross out the second row shown.
- 3 In the case of staggered buckets, be sure to note this on the diagram and indicate relative position of buckets on belt.
- 4 If any special instructions are necessary to punch the belt for butt or lap joints, note this beside the diagram below.
- 5 Unless otherwise specified belt will be punched the entire length with the spacing shown.

<input type="checkbox"/>	WORKSHEET NUMBER
<input type="checkbox"/>	BELT WIDTH
<input type="checkbox"/>	BUCKET SPACING SAME ROW
<input type="checkbox"/>	DISTANCE FROM END OF BELT TO FIRST ROW OF BUCKETS
<input type="checkbox"/>	DISTANCE BETWEEN FIRST ROW AND SECOND ROW OF HOLES
<input type="checkbox"/>	DIAMETER OF HOLES TO BE PUNCHED
<input type="checkbox"/>	SPACING OF HOLES
<input type="checkbox"/>	First row:
<input type="checkbox"/>	Second row:
<input type="checkbox"/>	NUMBER OF HOLES
<input type="checkbox"/>	First row:
<input type="checkbox"/>	Second row:
<input type="checkbox"/>	BUCKET SIZE

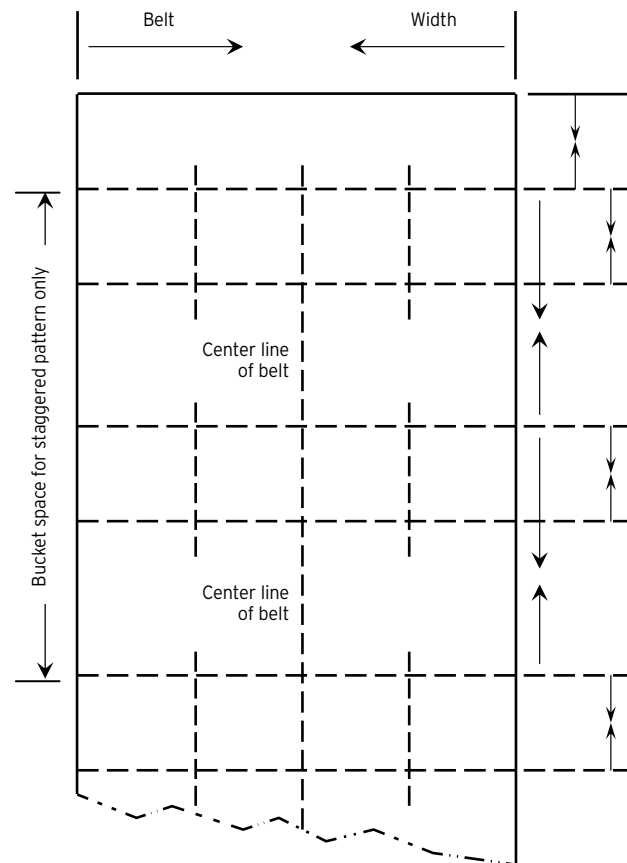

Special instructions:

GOODYEAR
GOODYEARBELTING.COM

Call Toll Free: 1-866-711-4673
International: +1-727-342-5086

**We Ship
World Wide**

CUT PARTS WORKSHEET

NAME:

COMPANY:

PHONE #:

EMAIL:

DATE:

Here's what we need from you.

- DRAWING OF THE PART WITH TOLERANCES. If material tolerances are not present, please tell us about the most critical dimensions.
- SAMPLE OF THE PART (IF AVAILABLE). The sample will help us to determine what method of manufacturing has been used in the past.
- MATERIAL SPECIFICATIONS OR POLYMER TYPE:
 - The full ASTM (American Society for Testing & Materials) call-out of the material is best
 - If the ASTM is not available, please provide specifications for:
 - ▶ Material:
 - ▶ Shore durometer:
 - ▶ Density:
 - ▶ Tensile:
 - ▶ Elongation:
 - ▶ Compression set:
 - ▶ UL recognition:
 - ▶ FDA (or other requirements):
 - ▶ Pressure sensitive adhesive type:
 - ▶ Color:
- TELL US ABOUT THE ENVIRONMENT WHERE THE PART WILL BE USED:
 - ▶ Temperature:
 - ▶ Chemicals:
 - ▶ Ozone:
 - ▶ Application:
- HOW WILL THE PART BE USED? (Strategically, dynamically, for sealing, etc.) This is helpful in determining the part's critical feature.
- QUANTITY AND ESTIMATED ANNUAL USAGE:
 - ▶ Do you require the parts all at once?
 - ▶ Is this a blanket order with periodic releases? At what intervals?
 - ▶ Or is this an repetitive, ongoing order?
- DELIVERY REQUIREMENTS:
 - ▶ When do you need the first shipment?
 - ▶ What is your preferred shipping method?
- PACKAGING REQUIREMENTS OTHER THAN STANDARD BULK PACK.
 - ▶ Labels (part number, UPC?)
 - ▶ Bagged or boxed quantity?

MOLDED & EXTRUDED PARTS WORKSHEET

Here's what we need from you.

NAME:

COMPANY:

PHONE #:

EMAIL:

DATE:

- DRAWING OF THE PART WITH TOLERANCES. If rubber tolerances are not present, please tell us about the most critical dimensions.
- SAMPLE OF THE PART (IF AVAILABLE). The sample will help us to determine what method of manufacturing has been used in the past.
- MATERIAL SPECIFICATIONS OR POLYMER TYPE
 - The full ASTM (American Society for Testing & Materials) call-out of the material is best
 - If the ASTM is not available, please provide specifications for:
 - ▶ Material:
 - ▶ Shore durometer:
- TELL US ABOUT THE ENVIRONMENT WHERE THE PART WILL BE USED:
 - ▶ Temperature:
 - ▶ FDA (or other requirements):
 - ▶ Chemicals:
 - ▶ Ozone:
 - ▶ Application:
- HOW WILL THE PART BE USED? Statically, dynamically, for sealing, etc.? This is helpful in determining a part's critical features.
- QUANTITY AND ESTIMATED ANNUAL USAGE:
 - ▶ Do you require the parts all at once?
 - ▶ Is this a blanket order with periodic releases? At what intervals?
 - ▶ Or is this an repetitive, ongoing order?
- TOOLING
 - ▶ For molded parts, does tooling already exist?
 - ▶ If yes, do you own the tooling?
 - ▶ What type is it? Compression, transfer or injection?
 - ▶ Can it be moved from your current supplier?
- DELIVERY REQUIREMENTS
 - ▶ When do you need the first shipment?
 - ▶ What is your preferred shipping method?
- PACKAGING REQUIREMENTS OTHER THAN STANDARD BULK PACK.
 - ▶ Labels (part number, UPC?)
 - ▶ Bagged or boxed quantity?

FOAM & SPONGE WORKSHEET

NAME:

COMPANY:

PHONE #:

EMAIL:

DATE:

Here's what we need from you.

- CAD DRAWING OF THE PART WITH TOLERANCES. If material tolerances are not present (and they frequently are not), inquire about the most critical dimensions. (R.M.A. Tolerances)
- SAMPLE OF THE PART (IF AVAILABLE).
- MATERIAL SPECIFICATIONS OR POLYMER TYPE
 - The full ASTM (American Society for Testing & Materials) call-out of the material is best
 - If the ASTM is not available, please provide specifications for:
 - ▶ Material:
 - ▶ Closed or open cell:
 - ▶ Shore OO Durometer:
 - ▶ Density:
 - ▶ Tensile (die A):
 - ▶ Tear strength (die C):
 - ▶ Elongation (die A):
 - ▶ Compression deflection:
 - ▶ Compression set:
 - ▶ UL recognition:
 - ▶ FDA (or other requirement):
 - ▶ PSA (pressure sensitive adhesive, rubber or acrylic-based):
 - ▶ Color:
- TELL US ABOUT THE APPLICATION AND ENVIRONMENT WHERE THE PART WILL BE USED:
 - ▶ Service temperature:
 - ▶ Chemical contact:
 - ▶ Ozone resistance:
 - ▶ Water absorption:
 - ▶ Combustion characteristics:
 - ▶ Application:
- QUANTITY AND ESTIMATED ANNUAL USAGE:
 - ▶ Do you require the parts all at once?
 - ▶ Is this a blanket order with periodic releases? At what intervals?
 - ▶ Is this a repetitive, ongoing order?
- DELIVERY REQUIREMENTS:
 - ▶ When do you need the first shipment?
 - ▶ What is your preferred shipping method?
- PACKAGING REQUIREMENTS OTHER THAN STANDARD BULK PACK:
 - ▶ Labels (part number, UPC?)

GOODYEAR
GOODYEARBELTING.COM

Call Toll Free: 1-866-711-4673
International: +1-727-342-5086

**We Ship
World Wide**



GOODYEAR
GOODYEARBELTING.COM

Call Toll Free: 1-866-711-4673
International: + 1-727-342-5086

We Ship
World Wide

Carrying all below and so much more! Call us...800-367-4673

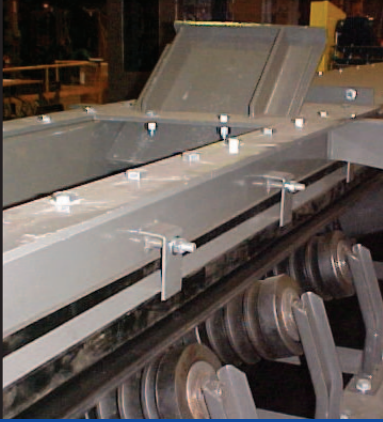

BELTING
Conveyor & Components



BRASS VALVES
and Fittings



EXPANSION JOINTS
Rubber, Metal & PTFE



FIRE PROTECTION
Hose, Nozzles, Reels



FLOOR
MATTING



FLUID SEALING
Packing & Seals



GASKETS
& Sheet Gasket Material

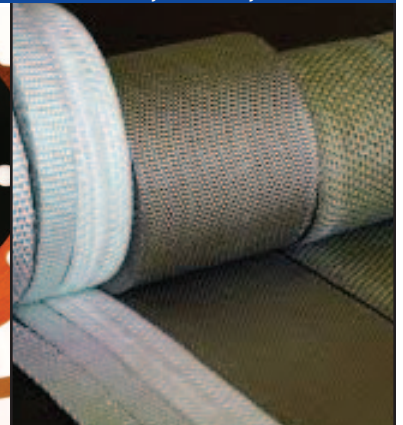

High Temperature
TEXTILES



HOSE
COUPLINGS



HOSE
CLAMPS

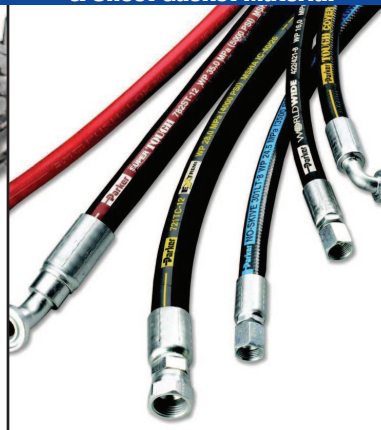

HYDRAULIC HOSE
Couplings & Adapters



INDUSTRIAL HOSE
Rubber & Plastic



GOODYEAR
GOODYEARBELTING.COM

Call Toll Free: 1-866-711-4673
International: +1-727-342-5086

We Ship
World Wide

Now Six Locations To Serve You!

CLEARWATER

12330 - 49th Street No., Clearwater, FL 33762
(727) 573-7745 • Fax (727) 573-7752
24-Hour Emergency Pager (813) 212-0469

FORT MYERS

12701 Metro Parkway, Ft. Myers, FL 33966
(239) 561-HOSE(4673) • Fax (239) 561-0018
24-Hour Emergency Pager (239) 332-9939

ST. PETERSBURG

1912 Central Avenue, St. Petersburg, FL 33712
(727) 822-4672 • (800) 367-4673 • Fax (727) 821-8721
24-Hour Emergency Pager (813) 212-1031

VISIT OUR WEBSITE:
www.goodyearrubberproducts.com

NAPLES

5530 Shirley St., Naples, FL 34109
(239) 596-0072 • Fax (239) 596-0073
24-Hour Emergency Pager (239) 332-9939

BRADENTON

6216 - 28th Street East, Bradenton, FL 34203
(941) 739-9777 • Fax (941) 739-9778
24-Hour Emergency Pager (941) 762-4673

TAMPA

5910 Adamo Drive (Hwy. 60), Tampa, FL 33619
(813) 627-8956 • Fax (813) 627-8957
24-Hour Emergency Pager (813) 201-4673

E-MAIL ADDRESS:
SALES@GoodyearRubberProducts.com



1-800-FOR-HOSE (367-4673)

o Meet Your Needs & Better Serve You WE NOW HAVE 24-HOUR EMERGENCY SERVICE

MOTIVE

Air Conditioning Hose
O.T. Brake Hose
Clutch Lines
Fuel Lines
General Purpose Hose
Water Hose
Power Steering
Turbo Sleeve

TS & BELTING

Conveyor Belt
Belts • Timing Belts
V-belts • Idlers
Fabrication

SE COUPLINGS

Industrial Tube Fittings
Plastic Fittings
Brazing Pipe Fittings & Valves
Hose Nipples

Quick Disconnect Couplers

GARDEN HOSE

Rubber/Plastic
Nozzles/Accessories

HARDWARE

Adhesives
Tape:Duct/Elect./PTFE
Rubber Straps w/Hooks
Pump Diaphragms
Paint Brushes
Plumbing Accessories

HYDRAULIC HOSE

Rubber & Thermoplastic Hose
Crimp Fittings
Reusable Fittings
Stainless Steel
Industrial Tube Fittings
Adapters
Crimp Machines & Fab Equip.
Metrics

INDUSTRIAL HOSE

AG Spray
Air, Multi-Purpose

Air, Recoil

Blower Hose
Chemical
Concrete Pump - Repairs
Contractors
Creamery
Discharge
Dryer Vent
Duct
Fluid
Food Transfer
Fuel-Gasoline/Diesel
Jetting
Material Handling
Metal Hose
Mill Hose & Fire Hose
Petroleum
Pressure Washer Hose
Sand Blast
Steam
Suction
Tar/Asphalt
Vacuum

Water Hose

Welding
Dock Guard & Bumpers
Exhaust Hose
Fuel Line, Vent, Fill Hose
General Purpose Hose
Sanitation & Gally Fill
Marine Steering Hose
Hydraulic Control Lines

MATTING

Anti-Fatigue
Door Mats
Mat Runners
Specialized
Personalized Mats

PROTECTIVE CLOTHING

Aprons
Boots
Gloves: PVC, Rubber, Leather
Rain Suits
Raincoats

SAFETY EQUIPMENT

Bump Caps
Safety Goggles, Glasses
Safety Hats
Safety Vests & Flags
Traffic Cones

TUBING

Nylon • Silicone
Polyethylene
Polypropylene
Reinforced Vinyl
Clear Vinyl • Gum

VALVES

Ball, Gate, Check
Actuated Valves
Needle Valves
Brass/Stainless/Plastic
Blow Guns
Filters
Regulators
Lubricators
Gauges

representing: Accuflex Industrial Hose • Allpax • Amatec • American Blitrite • Apache Hose & Belting • Apache Mills • Band-it • Baycon • Bee Valve • Belt Service • Boston Hose • Bradford Fittings • Brake Quip
Cannan Industries • Campbell Fittings • Conveyor Accessories • Darco Southern • Dixon Powhatan • Dixon Valve & Coupling • Duramax • Eaton • Everitte Couplings • Flexaust • Flexco • Flexible Technologies
• Flexitallc • Foam Fair Industries • Gateway Safety • Goodman Hewitt • Goodyear Engineered Products • Green Leaf • Hose Handlers, Int'l • HoseMaster • Hygenic Corporation
• Ideal / Tridon • Ja-Bar Silicone • Jason Industrial • Kanaflex • Kuriyama • Midland Metal • Mol Belting • Mulhern Belting • National Equipment Company • Novaflex • Oetiker • Pacific Echo • Parker Hannifin
Proco Products • PT Coupling • R3 Safety • SEPCO • Snap-Tite • Stucchi • Sun Flow • Synaflex • TAPCO • Teadit • Thermoid • Thermoseal • Titan Industries • U.S. Hose/Willcox/Tift • Unaflex • Uniband USA
• United Pacific Distributors • Urethane Solutions • Van Gorp • Veyance • Warco Blitrite • Webstone Company • Zone Distribution Company

RUBBER & PLASTIC PRODUCTS

For Home & Industry

1-800-FOR-HOSE

INDUSTRIAL HOSE & FITTINGS
HYDRAULIC HOSE & FITTINGS
INDUSTRIAL TUBE FITTINGS
PLASTIC TUBING & FITTINGS

AIR & WATER HOSE
MARINE HOSE
BRASS FITTING & VALVES
MATS & RUBBER MATTING

RUBBER BOOTS
GLOVES & RAINWEAR
RUBBER SHEETING & GASKETS
CONVEYOR BELT & POWER TRANSMISSION BELTS



BRADENTON

6216 - 28th Street E.
Bradenton, FL 34203
(941) 739-9777
Fax (941) 739-9778
24-Hour Emergency Pager
(941) 762-HOSE (4673)



On-Site Mobile Hose Repair



CLEARWATER

12330 - 49th Street No., Clearwater, FL 33762
(727) 573-7745
Fax (727) 573-7752
24-Hour Emergency Pager
(813) 212-0469



On-Site Mobile Hose Repair



FT. MYERS

12701 Metro Parkway
Ft. Myers, FL 33966
(239) 561-HOSE(4673)
Fax (239) 561-0018
24-Hour Emergency Pager
(239) 332-9939



On-Site Mobile Hose Repair



NAPLES

5530 Shirley St.
Naples, FL 34109
(239) 596-0072
Fax (239) 596-0073
24-Hour Emergency Pager
(239) 332-9939



On-Site Mobile Hose Repair



ST. PETERSBURG

1912 Central Avenue
St. Petersburg, FL 33712-1366
1-800-367-HOSE (4673)
(727) 822-4672
Fax (727) 821-8721
24-Hour Emergency Pager
(813) 212-1031



On-Site Mobile Hose Repair



TAMPA

5910 Adamo Drive (Hwy. 60)
Tampa, FL 33619
(813) 627-8956
Fax (813) 627-8957
24-Hour Emergency Pager
(813) 201-HOSE (4673)



On-Site Mobile Hose Repair

GOODYEAR
GOODYEARBELTING.COM

Call Toll Free: 1-866-711-4673
International: +1-727-342-5086

**We Ship
World Wide**