

Assembly Instructions

1. Cut tubing squarely—maximum of 15° angle allowable.
 - Use of Parker tube cutter PTC-001 is recommended.
2. Check that port or mating part is clean and free of debris.
3. Insert tubing into fitting until it bottoms.
 - Push twice to verify that tubing is inserted past collet and O-Ring.
4. Pull on tubing to verify it is fully inserted.
5. To disassemble, simply press release button, hold against body, and pull tubing out of fitting.

Note: in order to pass hot pull requirements of SAE J1131 a stainless steel tube support must be present in the end of the fitting before final fitting assembly.

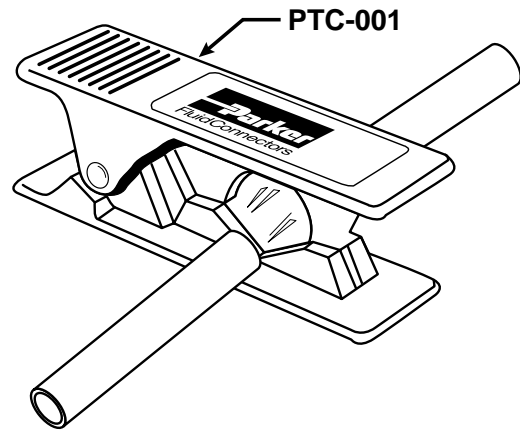

Tubing Nomenclature

*P F T - 4 A - G R N - 1 0 0 0

HOSE OR TUBING SIZE	COLOR	LENGTH (FEET)
4A 6B 8B 10B	GRN	
	BLU	
	BLK	
	YEL	
	ORG	
	RED	
	ETC.	

*Order from Parker Parflex Division

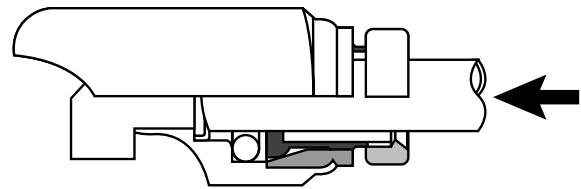

Insert tubing until it bottoms

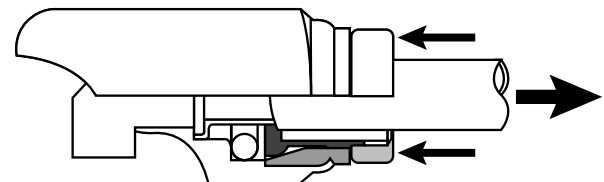

Depress button to remove tubing



[†] U.S. Patent No. 5,683,120