

FULL PORT BRASS GATE VALVE

VALVES

- **200 WOG (Cold water, oil, gas)**
- **125 WSP (Saturated Steam)**
- Brass Forged body/bonnet- stronger than sand castings.
- Superior quality and finish.
- Each valve individually tested.
- Threaded ends to ANSI B1.20.1, Solder ends to ANSI B16.18
- Non rising stem.
- Cast iron handle.

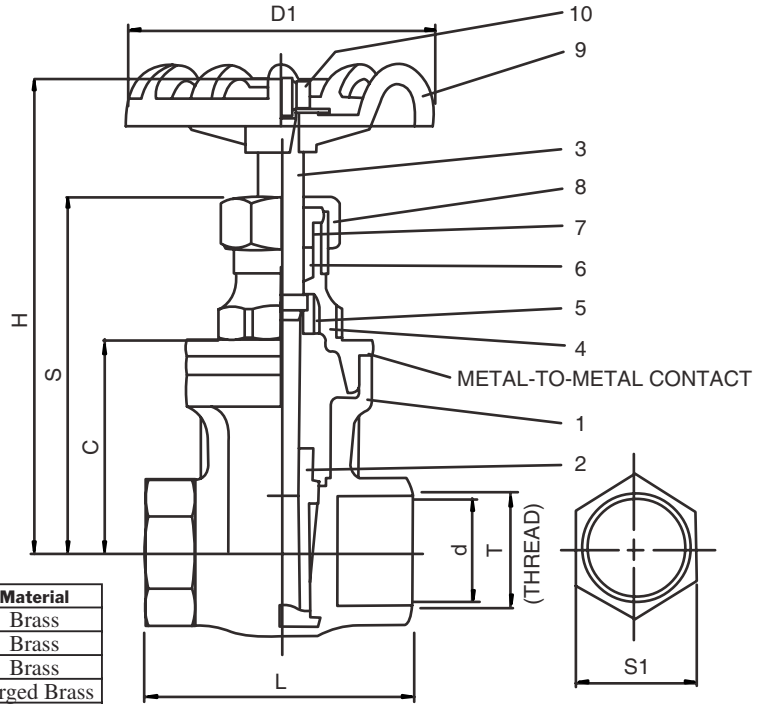

NO	Description	Material
1	Body	Brass
2	Disc	Brass
3	Stem	Brass
4	Bonnet	Forged Brass
5	Lock Nut	Brass
6	Packing	NBR
7	Gland	Brass
8	Packing Nut	Brass
9	Handwheel	Cast Iron
10	Handwheel Nut	SS4I

BRASS GATE VALVES IPS

Part#	Size	L	H	D1	d	C	S	T	S1	Box	Case	List
940-130	1/4	1.57	2.91	2.09	.24	1.22	2.09	1/4-18 NPT	.85	10	120	15.21
940-131	3/8	1.61	2.91	2.09	.39	1.22	2.09	3/8-18 NPT	.85	10	120	13.36
940-132	1/2	1.69	2.99	2.09	.51	1.30	2.17	1/2-14 NPT	1.03	10	120	11.50
940-133	3/4	1.89	3.31	2.09	.75	1.54	2.52	3/4-14 NPT	1.26	10	120	12.28
940-134	1	2.09	3.78	2.28	.98	1.77	2.83	1-11.5 NPT	1.51	5	60	19.03
940-135	1-1/4	2.36	4.33	2.87	1.22	2.17	3.43	1-1/4-11.5 NPT	1.84	4	40	34.67
940-136	1-1/2	2.44	4.88	2.87	1.46	2.52	3.78	1-1/2-11.5 NPT	2.12	2	30	43.93
940-137	2	2.76	1.65	3.31	1.89	2.87	4.57	2-11.5 NPT	2.64	1	20	62.50
940-138	2-1/2	3.43	7.24	3.94	2.44	3.62	5.67	2-1/2-8 NPT	3.23	1	8	69.00
940-139	3	3.78	8.35	4.41	2.95	4.25	6.42	3-6 NPT	3.78	1	8	161.00
940-140	4	4.49	10.08	5.12	3.60	5.39	8.31	4-6 NPT	4.84	1	4	363.54

C X C

Part#	Size	Box	Case	List
940-142	1/2	10	120	13.36
940-143	3/4	10	90	16.40
940-144	1	5	60	28.43

