

Gapping/ acceleration section

Identification

3

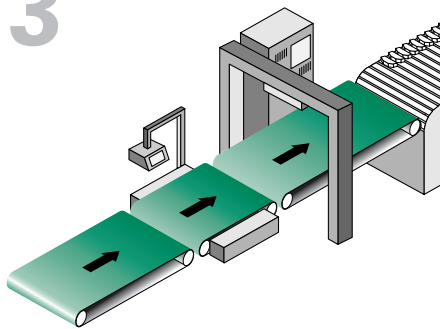

Check weigher, scale, scanner, labeling section

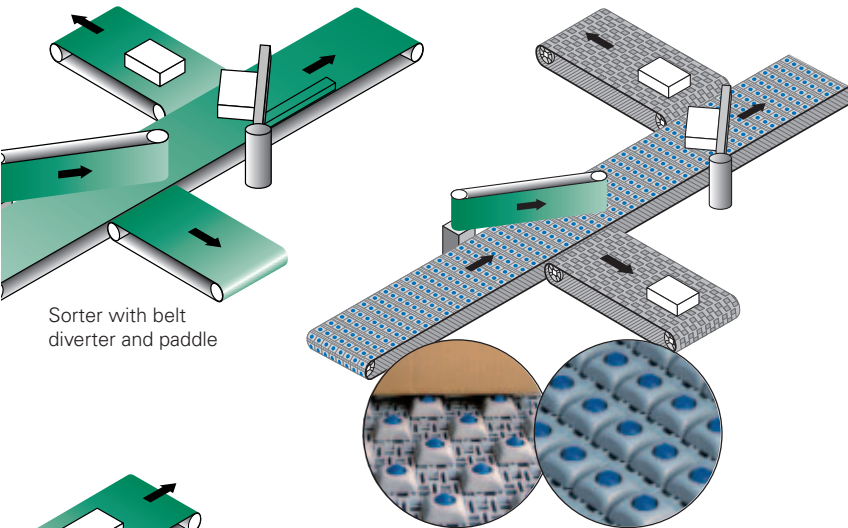

Sorter with belt diverter and paddle

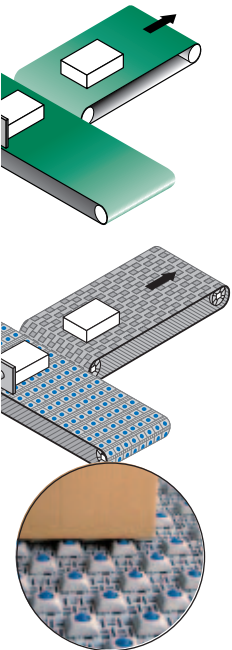

Outfeed, final stage

Deceleration belts

5

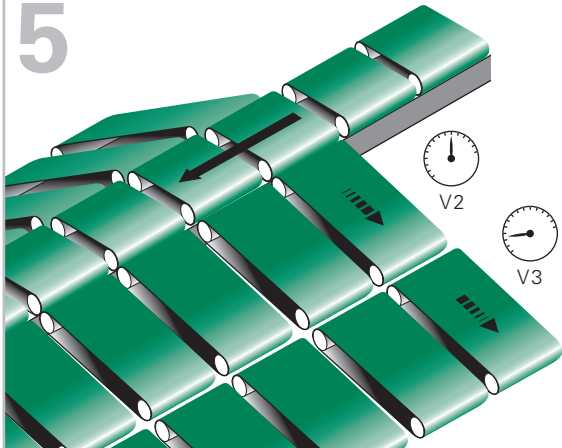

Conveyor sub systems, conveyor modules

Various live roller conveyors

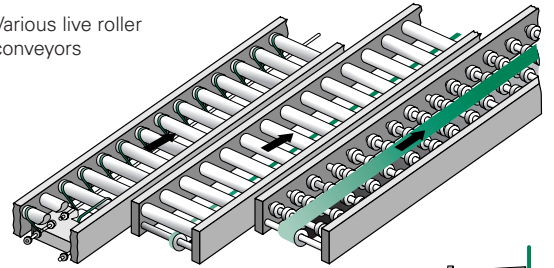

Live roller curve with round belt

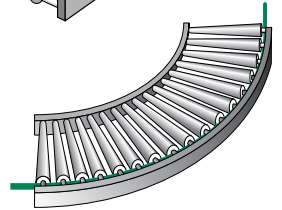

Power turn

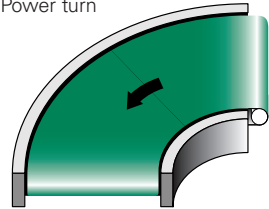

Modular belt radius conveyor

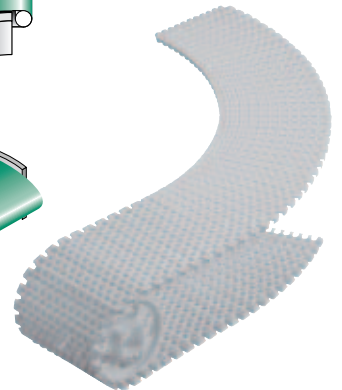
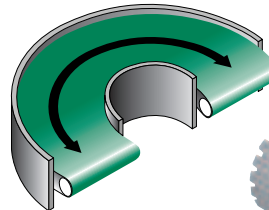

Z-conveyor/goose neck conveyor

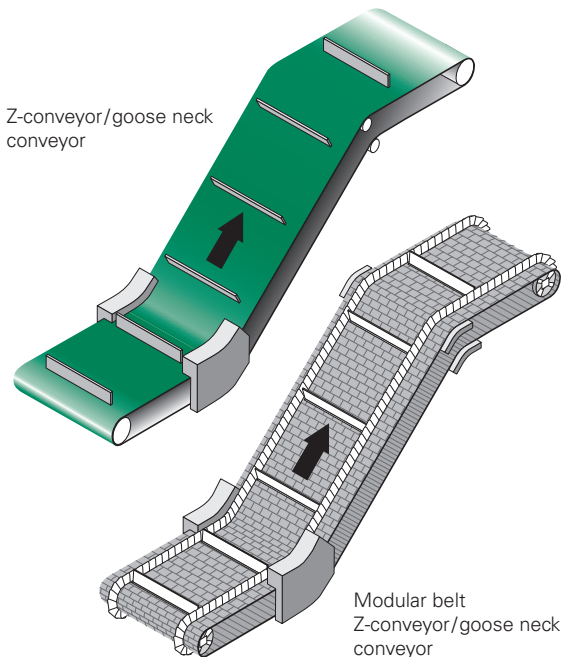

Modular belt Z-conveyor/goose neck conveyor