

MP-MP-MP Tee 5600 Series

SAE # 140437
(As coded per SAE J846)

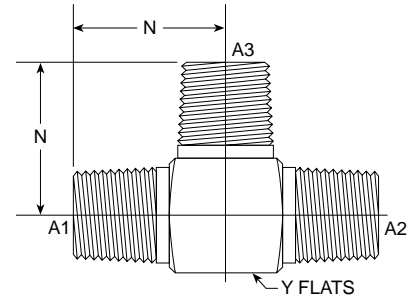

PART NO. SIZE	PIPE O.D.	A1 NPTF	A2 NPTF	A3 NPTF	N LGTH	M.M.	Y FLATS	Y FLATS	M.M.	Standard Material From Stock			
										S	FG	SS	B
5600-02-02-02	1/8	1/8-27	1/8-27	1/8-27	0.780	19.81	1/2	0.500	12.70	•	•	•	
5600-04-04-04	1/4	1/4-18	1/4-18	1/4-18	1.090	27.69	5/8	0.625	15.88	•	•	•	
5600-06-06-06	3/8	3/8-18	3/8-18	3/8-18	1.220	30.99	13/16	0.812	20.62	•	•	•	
5600-08-08-08	1/2	1/2-14	1/2-14	1/2-14	1.470	37.34	15/16	0.937	23.80	•	•	•	
5600-12-12-12	3/4	3/4-14	3/4-14	3/4-14	1.590	40.39	1 1/8	1.125	28.58	•	•	•	
5600-16-16-16	1	1-11 1/2	1-11 1/2	1-11 1/2	1.970	50.04	1 3/8	1.375	34.93	•	•	•	
5600-20-20-20	1 1/4	1 1/4-11 1/2	1 1/4-11 1/2	1 1/4-11 1/2	2.380	60.45	1 5/8	1.625	41.28		•		
5600-32-32-32	2	2-11 1/2	2-11 1/2	2-11 1/2	3.000	76.20	2 1/2	2.500	63.50		•		

MP-MP-FP Tee 5601 Series

SAE # 140427
(As coded per SAE J846)

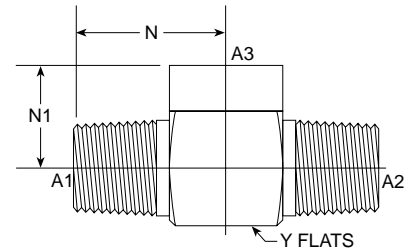

PART NO. SIZE	PIPE O.D.	A1 NPTF	A2 NPTF	A3 NPTF	N LGTH	M.M.	N1 LGTH	M.M.	Y FLATS	Y FLATS	M.M.	Standard Material From Stock			
												S	FG	SS	B
5601-02-02-02	1/8	1/8-27	1/8-27	1/8-27	.78	19.81	0.66	16.76	9/16	0.562	14.27	•	•	•	
5601-04-04-04	1/4	1/4-18	1/4-18	1/4-18	1.110	28.19	0.890	22.61	3/4	0.750	19.05	•	•	•	
5601-06-06-06	3/8	3/8-18	3/8-18	3/8-18	1.230	31.24	1.020	25.91	7/8	0.875	22.23	•	•	•	
5601-08-08-08	1/2	1/2-14	1/2-14	1/2-14	1.560	39.62	1.240	31.50	1 1/8	1.125	28.58	•	•	•	
5601-12-12-12	3/4	3/4-14	3/4-14	3/4-14	1.600	40.64	1.360	34.54	1 3/8	1.375	34.93	•	•	•	
5601-16-16-16	1	1-11 1/2	1-11 1/2	1-11 1/2	1.980	50.29	1.630	41.40	1 5/8	1.625	41.28	•	•	•	
5601-20-20-20	1 1/4	1 1/4-11 1/2	1 1/4-11 1/2	1 1/4-11 1/2	2.370	60.20	1.690	42.93	2	2.000	50.80	•	•		
5601-24-24-24	1 1/2	1 1/2-11 1/2	1 1/2-11 1/2	1 1/2-11 1/2	2.620	66.55	2.130	54.10	2 1/2	2.500	63.50	•	•		